



**PROPRIOCEPTION IS "CENTRAL" TO MOTOR LEARNING: DIFFERENT  
CONSEQUENCES OF PERIPHERAL AND CENTRAL PROPRIOCEPTIVE  
DISRUPTION TO SEQUENCE LEARNING**

Eric Dennis Vidoni  
M.S. University of Kansas Medical Center, Physical Therapy  
B.S. University of Illinois at Urbana-Champaign, Kinesiology

Submitted to the graduate degree program in Physical Therapy and Rehabilitation Science  
and the Graduate Faculty of the University of Kansas in partial fulfillment of the  
requirements for the degree of Doctor of Philosophy

  
\_\_\_\_\_  
Lara A. Boyd, PT, Ph.D  
(Co-chair)

  
\_\_\_\_\_  
Irina V. Smirnova, Ph.D  
(Co-chair)

  
\_\_\_\_\_  
Wen Liu, Ph.D

  
\_\_\_\_\_  
Brian McKiernan, PT, Ph.D

  
\_\_\_\_\_  
Randolph J. Nudo, Ph.D.

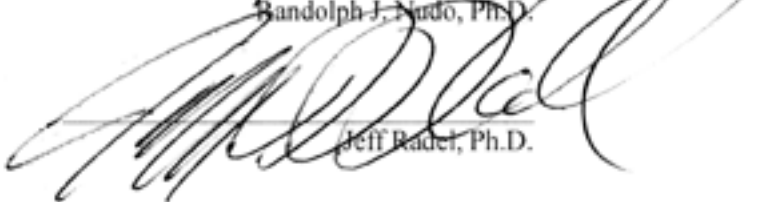
  
\_\_\_\_\_  
Jeff Badet, Ph.D.

  
\_\_\_\_\_  
Date of Dissertation Defense

The dissertation committee for Eric Dennis Vidoni certifies that this is the approved version of the following dissertation:

**PROPRIOCEPTION IS “CENTRAL” TO MOTOR LEARNING: DIFFERENT CONSEQUENCES OF PERIPHERAL AND CENTRAL PROPRIOCEPTIVE DISRUPTION TO SEQUENCE LEARNING**

Committee:



Lara A. Boyd, PT, Ph.D  
(Co-chair)



Irina V. Shtirnova, Ph.D  
(Co-chair)



Wen Liu, Ph.D



Brian McKiernan PT, Ph.D

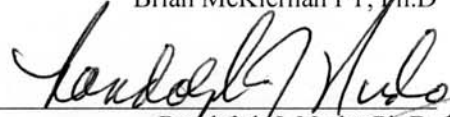

Randolph J. Nudo, Ph.D

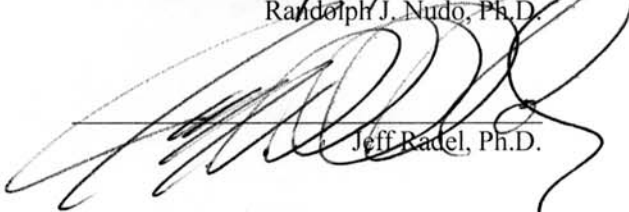

Jeff Badel, Ph.D.

24 January 2008

Date Approved

## **Abstract**

It has long been a goal of the human movement research community to develop a more complete understanding of how individuals learn complex patterns of movement. This knowledge is useful to both those engaged in precision activities such as the hitting a baseball as well as those determined to improve motor function following neurologic injury such as a stroke. The following dissertation explores one component of the motor learning process: the role of sensation, specifically proprioception, in motor learning. Two questions were addressed. First, does peripheral disruption of proprioceptive sensation impair sequence-specific learning? Second, what is the relationship between sequence-specific learning and stroke related proprioceptive deficit?

Because little is known about the role of proprioception in learning movement patterns the first aim of this study, presented in Chapter 2, sought to characterize skill acquisition in healthy adults when proprioceptive sensation was disrupted. Twelve participants (DIS) were randomly assigned to receive vibration to the upper arm while performing a continuous tracking task. Twelve additional subjects (CTL) served as a comparison group and received vibration to the arm that was not being used to track. Despite initially less accurate performance by the DIS group, both groups learned to track a repeated sequence of movements, indicating that accurate peripheral report of limb state may not be crucial for motor learning. Rather the motor learning system appears to be robust and capable of utilizing other sources of information for error correction and motor plan development.

Vision is one likely source of information used by the central nervous system (CNS), concomitant with or in place of proprioception. Previous work has consistently demonstrated a close link between visual and manual motor performance. Further, the visual system is

capable of learning stimulus regularities. However, visual and manual learning during continuous sequence tracking has not been investigated previously. To address this gap in the literature, 9 healthy young adults performed a continuous tracking task similar to that described in Chapter 2. Eye movements were recorded during manual tracking. It was found that though performance improved for both visual and manual tracking over practice, eye and motor accuracy were relatively independent. Tracking performance of either effector (i.e., arm versus eye) on individual trials was not predictive of performance on the other effector. Thus, reflecting somewhat the findings on proprioception in Chapter 2, it was concluded that though vision may be an important component of sensory information, a high degree of visual tracking accuracy is not critical for continuous motor sequence learning.

In Chapter 4, the focus shifted to proprioceptive disruption following central neurological insult. Ten survivors of stroke and 9 age-matched, neurologically intact control participants engaged in a continuous tracking task similar to that presented in Chapter 2. However, no exogenous sensory disruption was applied during training. Instead, sensory disruption was an endogenous consequence of stroke. The level of central proprioceptive disruption was indexed using a limb-position matching task. The healthy participant group was able to learn sequence-specific components of the task. As a group, stroke survivors also demonstrated continuous sequence learning. However, proprioceptive accuracy was strongly correlated with sequence-specific versus general task improvement in continuous tracking within this group. These data support the animal literature that suggests central somatosensory integrity is critical for novel skill learning.

Finally, the cerebellum is often identified as a substrate of motor learning. Furthermore, the cerebellum has extensive access to ascending afferent somatosensory information. To examine the use of proprioceptive information by the cerebellum, 7

individuals with cerebellar damage were recruited to perform the same continuous tracking task. Contrary to previous reports, some individuals in this study learned to perform a sequence of movements with their more involved hand. However, two exhibited no such learning. These individuals had large lesions encompassing the lateral cerebellar cortex. They also demonstrated proprioceptive deficit and motor ataxia. These results suggest that learning of movement sequences may be in part related to somatosensory discrimination and error-feedback learning performed in the cerebellar cortex.

In summary, the results suggest that though body state information may be important for learning, central and peripheral disruption of proprioceptive information are not analogous in terms of the impact on continuous motor sequence learning. Rather, in addition to proprioception, other sources of afferent information may be used to learn a new skill. In some situations these sources of information, including vision and planning, can operate and encode movement sequence components independent of each other, resulting in skill learning. However, integrity of central information processing systems appears to be an important component of continuous sequence learning. Rehabilitation professionals should consider the state of a client's proprioceptive system when developing a plan of care.

## **Acknowledgements**

*“It's all a lot of simple tricks and nonsense.” - Han Solo*

Those who have been around me the last 5 1/2 years have no doubt heard me utter some less printable variation of this skepticism. Nevertheless, over the course of my education I've come to an uneasy truce with both science and physical therapy. This is primarily a function of those around me who have supported and challenged me.

First, to my parents, whom I dedicate this dissertation. No son could have received more unconditional support and love. You have instilled a desire to learn that has driven me down this path. I love you.

Next to my mentor, Lara. I could not have hoped for a better mix of independence and assistance. I hope I can be as inspiring to my students as you have been to me. Thank you. Much gratitude goes to my helpful, engaged and flexible dissertation committee; thank you for challenging me with great ideas. To Jason McCarley, mentor, friend and collaborator, thank you for your vital assistance with Chapter 3. And thanks to Brenda Wessel and Tara Klassen for help with organizing and testing participants in Canada. It is important also to acknowledge the support of Kansas Partners in Progress, Inc., the Vancouver Coastal Health Research Institute and Foundation and the North Growth Foundation for their financial support of this project.

Importantly, I want to recognize the study participants who gave their time, ideas and sometimes friendship. These individuals take the long view on research and science, giving of themselves freely even when the findings are unlikely to immediately benefit them. Thanks also to my clinical mentors and friends, Kerry and Chessica and the Timber Ridge family who have given me so much of themselves.

To Mahoney, you are as close to a brother as I'll ever have. Thank you for understanding why a guy would want to stay in school this long. To Todd, Stacy, and now Madeline, the best-lab-mate-ever Katie, Tim, and Lucy: thank you for your friendship and making a place for me in your lives and homes. To Lisa CS and Dennis, you both have made my school life much easier. To the PhD students and faculty: I appreciate your dedication to challenging us all to strive for more. Specifically, I want to thank the Usual Suspects, both past and present: Kevin, Joe, Marcio, Mukul, Raj, Holly, Huny, Muhammad, Lisa, Kendra and Steve-o. Thank you for your time and patience with me. You have demonstrated a dedication to making us better scientists and clinicians and I believe it will be to the benefit of us all. To Michelle, Betsy and my house. You have helped create a home and diversion for me just south of school that I appreciate more than you know.

Finally, to Sandra Anne. Simply, thank you. Have I told you that I think you are amazing?

*Omnia possum in eo, qui me confortat.*

## Table of Contents

<b>Abstract</b>		iii
<b>Acknowledgements</b>		vi
<b>Table of Contents</b>		viii
<b>List of Tables and Figures</b>		xi
<b>Chapter 1</b>	<b>Introduction</b>	
1.1	Overview	2
1.2	Motor Control and Learning Theory	3
1.3	Internal Models	4
1.4	Proprioception	7
1.4.1	Proprioception and Peripheral Sensors	8
1.4.2	Proprioception and Central Perception	10
1.5	Proprioception and Motor Control	12
1.6	Sensation and Motor Learning	14
1.7	Stroke	16
1.8	Distinction of Experimental Design	18
1.9	Significance of Presented Work	19
1.10	Specific Aims & Statement of Hypotheses	20
1.11	Figures	23
<b>Chapter 2</b>	<b>Preface</b>	24
	<i>Motor Sequence Learning Occurs Despite Altered Visual and Proprioceptive Feedback</i>	
2.1	Abstract	26
2.2	Introduction	27

2.3	Experiment 1	29
2.3.1	Methods	30
2.3.2	Results	32
2.3.3	Discussion	33
2.4	Experiment 2	33
2.4.1	Methods	33
2.4.2	Results	38
2.5	General Discussion	40
	Tables and Figures	45
<b>Chapter 3</b>	<b>Preface</b>	54
	<i>Manual and Oculomotor Performance Develop Contemporaneously But Independently During Continuous Tracking</i>	
3.1	Abstract	56
3.2	Introduction	57
3.3	Methods	59
3.4	Results	62
3.5	Discussion	64
	Tables and Figures	68
<b>Chapter 4</b>	<b>Preface</b>	74
	<i>Stroke-related Proprioceptive Deficit is Associated With Disrupted Motor Learning</i>	
4.1	Abstract	76
4.2	Introduction	77

4.3	Methods	79
4.4	Results	85
4.5	Discussion	87
	Tables and Figures	94
<b>Chapter 5</b>	<b>Preface</b>	101
	<i>Preserved Continuous Motor Sequence Learning in Some Individuals with Cerebellar Pathology</i>	
5.1	Abstract	103
5.2	Introduction	104
5.3	Methods	107
5.4	Results	112
5.5	Discussion	114
	Tables and Figures	121
<b>Chapter 6</b>	<b>Discussion and Conclusions</b>	
6.1	Summary of Findings	128
6.2	Limitations	131
6.3	Sequence Learning and Proprioception	135
6.4	The Internal Model and Movement Sequences	138
6.5	Clinical Implications	143
6.6	Future Directions	145
6.7	Conclusions	147
	<b>References</b>	149
<b>Appendix 1</b>	<b>Target Waveform Creation</b>	175
<b>Appendix 2</b>	<b>Future Directions?</b>	177

## List of Tables and Figures

### Chapter 1

Figure 1.1	The Internal Model	23
------------	--------------------	----

### Chapter 2

Table 2.1	Limb Position Matching Conditions	45
Table 2.2	Testing Schedule and Conditions	46
Figure 2.1	Experimental Setup	47
Figure 2.2	Effect of Vibration on Limb Excursion Sense	48
Figure 2.3	Tracking Performance Examples	49
Figure 2.4	Tracking Error	50
Figure 2.5	Spatial Tracking Error	52
Figure 2.6	Temporal Tracking Error	53

### Chapter 3

Table 3.1	Regression Statistics	68
Figure 3.1	Real-time Tracking Error	69
Figure 3.2	Trialwise Manual and Oculomotor Tracking Error	70
Figure 3.3	Spatial Tracking Error	71
Figure 3.4	Temporal Tracking Error	72
Figure 3.5	Goodness of Fit for Tracking Error Regression Models	73

### Chapter 4

Table 4.1	Participant Characteristics	94
Figure 4.1	CVA Group Lesion Locations	95
Figure 4.2	Tracking RMSE	96
Figure 4.3	Relationship Between Proprioception and Motor	97

	Learning	
Figure 4.4	Relationship Between Motor Function and Motor Learning	99
	Learning	
<b>Chapter 5</b>		
Table 5.1	Participant Characteristics	121
Figure 5.1	CB Pathology	122
Figure 5.2	Lag-corrected Velocity Tracking Accuracy	123
Figure 5.3	Temporal Accuracy	125

## **Chapter 1**

### **Introduction**

## *1.1 Overview of Significance*

Our understanding of the complex interactions between the sensory and motor systems has grown exponentially since the early reflex-based model of Sherrington.(1906) Yet, current evidence continues to suggest an important role for sensation, proprioception in particular, in the development and execution of skilled motor behaviors. Elegant demonstrations of long-term potentiation of motor cortical neurons via thalamocortical and cortico-cortical interaction (Iriki et al. 1989; 1991) have elucidated a potential sensorimotor learning pathway. Convergent evidence demonstrating that induced lesions of the sensory cortex diminish skill learning in monkeys (Pavlices et al. 1993) led Asanuma and Pavlices (1997) to postulate that the sensory cortex may ‘teach’ the motor cortex new motor skills. In addition, other brain structures with rich access to afferent information, such as the cerebellum, have been associated with motor learning.(Imamizu et al. 2000)

Despite the evident importance of sensorimotor interaction, we remain unsure how or in what instances sensory information is used during skill learning. Further, no work has specifically examined the role of proprioception in learning a continuous movement sequence, such as writing a signature, that require online evaluation of feedback<sup>1</sup> as well. Study of these types of tasks is important because they are common to our daily activity. They differ from common key press paradigms by requiring greater precision of movement. Some evidence suggests that the discrepancy between an expected reference signal and actual muscle spindle information is treated as error and the motor program updated accordingly

---

<sup>1</sup> For the purposes of this dissertation, use of the term “feedback” will refer to information directly received from and about our interaction with the environment. This definition is equivalent to “sensory feedback” as discussed by Desmurget and Grafton (2000). Strict usage of the term is done for the purposes of readability and clarification for the reader, as the study of proprioception is significantly concerned with “sensory” feedback. It is recognized that feedback has internal sources as well. Specific reference will be made when referring to these sources of “non-sensory” or “internal” feedback.(Desmurget, 2000)

during discrete movement.(Thoroughman and Shadmehr 2000) Therefore, an erroneously revised motor program based on disrupted or absent limb position information should interfere with task learning. This hypothesis was tested in the following work by characterizing skill learning in participants with either exogenously (vibration) or endogenously (neurological damage) altered proprioceptive sensation. **The primary purpose of the present work is to contribute to the characterization of the role of proprioception in learning of continuous movement sequences.** In doing so, it is hoped that a better understanding of the challenges faced by those with impaired proprioceptive function will be gained.

### *1.2 Motor Control and Learning Theory*

How the brain actually acquires and reproduces skilled movements remains unclear. Other than the obligatory synapses of the peripheral neuromuscular junction our understanding of neuromotor activity is clouded by several layers of complexity. At the cellular level the brain appears to be a complicated web with myriad projections and synaptic interactions. Adding to the confusion are multiple functional divisions of the brain, each of which participate in loosely defined capacities before and during movement.(Krakauer and Ghez 2000) Neuromotor control theory is likewise cloudy. Multiple theories have been posited, including internal models,(Kawato and Wolpert 1998) the equilibrium-trajectory hypothesis,(Hogan et al. 1987) and the dynamical systems perspective.(Schoner and Kelso 1988)

Without a clear understanding of the neurophysiology that underpins motor control processes, motor learning theories stand on shaky ground. Despite this, a plausible explanation for the process of motor learning and execution is beginning to develop. Long-

term potentiation (LTP) or depression (LTD) of neurons is a leading candidate for the development of focused pathways that act repeatedly in a movement.(Iriki et al. 1989; Ito 2000) Focusing of these pathways represents the neural substrate of the internal model, a theoretical control structure. The internal model is a highly conceptual and flexible construct that accounts for sensory lag and continuous movement adjustment. When a motor plan is selected, rough motor commands are issued based on a goal (e.g. to pitch a fastball, low and away). Prior to and during movement execution, the internal model updates movement based on its own predictions and incoming sensory information. Following the action the model can be updated based on success of the movement (e.g. the pitch went over the catcher's head, release a little later next pitch).(Kawato and Wolpert 1998)

### *1.3. Internal Models*

The concept of the internal model (Kawato and Gomi 1992; Kawato and Wolpert 1998; Wolpert et al. 1995) has developed out of the recognized paradox of real-time, precise motor control that relies on a physiological system with delayed access to sensory information.(Desmurget and Grafton 2000) This makes simple, immediate control and adjustment of movement based on feedback difficult. Previous motor control researchers accounted for this by emphasizing advance planning, or open-loop control in which an entire motor plan could be executed without the need for feedback. This “motor schema” stored basic invariant features of the behavior such as movement sequence and phase.(Schmidt 1975) Following modification by other variables such as desired force or duration, the motor command could be sent to the muscles and the complete action performed. The motor schema could be updated following execution based on a comparison of the expected outcomes and sensory consequences and the feedback regarding what actually occurred.

The internal model shares much in common with the motor schema: attention to initial conditions, response specifications, predictions of sensory consequences and response outcome. However, the internal model allows for more flexibility of control during movement than the schema.(Vercher et al. 2003) Both concurrent feedback and skill memories can be used to update and guide movement. For example, reaching for your familiar bedroom light switch in the dark can be performed with reasonable accuracy but is much more effectively performed when the light is already on and vision is available to update the movement.(Carlton 1981; Hocherman and Levy 2000; Keele and Posner 1968)

Two components of the internal model have been proposed that account for this flexibility (see Figure 1.1). The inverse model receives the desired and current, perceived state as input and computes a motor command to achieve that goal.(Kawato and Gomi 1992) An (efference) copy of the motor command is sent to the forward model. Forward models are predictive in nature and allow the CNS advance access to the likely sensory outcome of a motor command.(Davidson and Wolpert 2005) The predictions of the forward model can be returned to the inverse model so as to issue corrective commands prior to receiving any afferent feedback. The predictions can also be used to issue commands to other systems regarding the necessary dynamics of an upcoming action. Information transmission between models allows for coordinated actions between effectors such as the manual and oculomotor systems.(Vercher et al. 2003; see also Davidson and Grafton, 2000 for a review)

Evidence for the inverse model comes both from our obvious ability to perform goal directed movements as well as our knack for adapting those behaviors in the face of environmental change. Individuals can learn new dynamics and generalize them to other situations (e.g. swinging an aluminum versus a wooden baseball bat).(Shadmehr and Mussa-Ivaldi 1994) Motor commands are adjusted based on new inverse models of environmental

dynamics. That is, the brain learns what commands to issue to get from position A to position B despite a novel force C. This is believed to occur through error-feedback learning, possibly in the cerebellum.(Kawato and Wolpert 1998) As both feedback returns to the CNS it is compared to the motor plan in the case of the inverse model or the estimated state in the case of the forward model. Adjustments can be made for the next attempt at the skill. The functional units of the cerebellum (microzones) have been attractive candidates for adaptation. Climbing fibers may carry error signals that modify the output of Purkinje cells through LTD.(Ito 2000) Imamizu and colleagues (2000) reported localization of the internal model in the cerebellum following a visual transformation learning task.

Evidence for the forward model can also be found in the literature. One well-used paradigm in forward model research is grip-load force coupling.(Johansson et al. 1992; Quaney et al. 2003; Witney and Wolpert 2003) In this paradigm, participant grip force is monitored as an object is picked up. Failure of the forward model to predict the necessary grip force can lead to dropping the object: an unwelcome event if the object is a full glass of red wine and you are on white carpet. Forward models are believed to assist the planning and execution so that lift and grip are coupled for a successful movement. Without access to a prediction of the consequences of a given load force, an appropriate grip force cannot be calculated in time.(Kawato 1999)

Other systems, such as vision and sensation, are believed to have access to the expected outcomes and can make predictions or issue motor commands based on the output of the forward model.(Davidson and Wolpert 2005) For example, tickling yourself is difficult. This is believed to result from a forward model prediction the brain makes regarding sensory consequences of your actions. Because the CNS expects certain consequences, the actual sensation of you touching the bottom of your feet with a feather is

not perceived as being very ticklish.(Blakemore et al. 2000) In contrast, were someone else to do the same without your awareness, your ability to predict the upcoming sensation would be minimized and the ticklish sensation would be much more apparent.

While most researchers have essentially placed the entire internal model in the cerebellum,(Imamizu et al. 2003; Ito 2000) a few have considered the cerebral cortex to be a key player. Fisher and colleagues have proposed that inverse models exist in the sensorimotor cortex and the forward model in the cerebellum.(Fisher et al. 2006; Fisher et al. 2000) This is based on convergent findings using a timed response paradigm that forces a movement choice with little or no information about where to move. Individuals with lesions of the sensorimotor cortex have preserved planning but not updating ability whereas those with cerebellar lesion have difficulty with planning but not updating movements. In addition, primate studies have noted modulation of neuronal firing in supplementary motor area (Halsband et al. 1994) and M1 (Matsuzaka et al. 2007) specific to learned movement sequences. Indeed, because of the close association of sensation and movement production, sensorimotor cortex is a logical place for the translation of perceived and desired state differences to motor commands. However it remains to be seen if future research supports this contention.

#### *1.4 Proprioception*

Proprioception is the integration and interpretation of joint, muscle and cutaneous afferent signals regarding the position and movement of the limbs and body.(Gardner and Kandel 2000) Previous work has demonstrated the importance of proprioception for the acquisition and maintenance of motor plans that account for the internal and external forces the limb will encounter during a movement.(Pipereit et al. 2006; Vercher et al. 2003) Some

evidence suggests that proprioceptive feedback forms a template for comparison to the motor plan during repetitive skill practice. This process may operate through the tuning of electromyographic activity over practice using proprioceptive information as a guide.(Thoroughman and Shadmehr 1999) Extending these findings, Hwang and Shadmehr (2005) noted that computer simulations of muscle spindle-based learning closely matched human learning of a reaching task in a force field. Gordon et al. (1995) examined participants with deafferentation due to large fiber neuropathy. These individuals not only had difficulty reaching in a specific and focused direction but also could not correct movements with regard to limb inertia in a specific direction. These data suggest that limb position sense is key to maintaining a representation of the body's own dynamics.

As presented in the next two sections, this peripheral afferent information is processed by several regions of the central nervous system (CNS) including the parietal cortex and cerebellum. Because a significant portion of the present work relies on an exogenous shift of proprioceptive sensation by vibration, a brief description of the peripheral sensors is indicated and is presented first. It should be noted that kinesthesia is the conscious perception of proprioceptive signaling and will be used throughout the manuscript to specifically identify conscious awareness of body positioning and not as a synonym for proprioception.

#### *1.4.1 Proprioception and Peripheral Sensors*

Mechanoreceptors in the skin over the joints likely participate to some degree in proprioception and motor control, conveying information about the changing pattern of contact between the limb and adjacent objects.(Darian-Smith 1984) These hairy skin mechanoreceptors are slightly different from those of the glabrous, palmar skin in that their

response to vibration on these endings is 5-10 times greater. The slowly adapting afferent fibers appear to come from Merkel corpuscles and Ruffini endings. Merkel endings and their slow adapting (SAI) afferent fibers respond to skin indentation and maintain their output over time. Ruffini endings and their associated SAII afferents appear to be more responsive to skin stretch and vibration.(Gardner and Kandel 2000)

Fast adapting afferents have been more extensively studied. Vibration sensed by Pacinian and Meissner's corpuscles fire in one-to-one relationship with vibratory cycle (including the frequencies used in the present study) early during stimulation but attenuate over time.(Darian-Smith 1984) It is likely that these endings participate significantly in proprioception and that vibration can alter the cutaneous contribution to position and movement sense. Short term vibration can lead to increases in sensitivity threshold and numbness (Malchaire et al. 1998) and studies of muscle vibration coupled with skin stretch report stronger movement illusion than vibration alone.(Collins et al. 2000; Collins et al. 2005)

Less work has been done on vibration of joint structures themselves than the skin covering them. Pacinian corpuscles and Ruffini endings are thought to report information on joint capsule movement.(Darian-Smith 1984) The SA afferents of the Ruffini endings may continuously report on capsular stretch in a particular zone. The rapidly adapting afferents associated with Pacinian corpuscles appear to fire during movement of the joint. Little is known about the proprioceptive effect of vibration on these structures and even less on the bones they connect. Golgi tendon organs appear to respond to vibration but only at low frequencies.(Vedel and Roll 1983)

Static and dynamic muscle stretch information is provided by sensory endings wound around intrafusal muscle spindle bundles. These intrafusal fibers are laid in parallel with the

force producing extrafusal fibers. Primary spindle afferents modulate their firing frequency in response to both the static and dynamic stretch of a muscle.(Pearson and Gordon 2000) Vibration is recognized as an effective means of stimulating primary muscle spindle afferents.(Brown et al. 1967; Roll and Vedel 1982; Roll et al. 1989) These sensory receptors generally fire in a one-to-one relationship with the vibration stimulus (Roll and Vedel 1982) and can produce illusions of movement or false position sense,(Cordo et al. 1995b; Goodwin et al. 1972; Gooney et al. 2000) even when the vibration is indirect or generalized to the whole body.(Fontana et al. 2005; Schmid et al. 2005) These illusions are most significantly produced with a vibration frequency between 60-80 Hz.(Roll and Vedel 1982; Sittig et al. 1987) Goodwin and colleagues (1972) reported that participants unable to visualize their limb report that vibration causes a sensation of joint movement in the direction that would elongate the stimulated muscle. Furthermore, the authors reported that even when voluntarily moving the vibrated arm, participants overestimated muscle stretch.

In a continuous tracking task such as the one employed in the present work, upper extremity position and velocity change is continuous and likely results in significant primary spindle activity. For this reason, it was chosen as the primary target for temporary stimulation. Rather than a more involved method such as hypoxic restriction, indirect vibration to the shoulder musculature results in a perceptual shift of both position and tactile sensation based on the descriptions of pilot subjects. Bock et al. (2007) recently confirmed the efficacy of vibration for the study of motor control.

#### *1.4.2 Proprioception and Central Perception*

Following sensory registration of movement, afferent signals pass to several structures in the brain via multiple pathways including the dorsolateral and the

spinocerebellar tracts. Cortically bound information synapses in the ventral posterolateral nucleus of the thalamus before ascending to the post-central gyrus. Though areas 3a and 2 of the primary somatosensory cortex (S1) are commonly associated with proprioception, all areas of S1 appear to receive stimulus information following a movement.(Costanzo and Gardner 1981; Soso and Fetz 1980) This may reflect the multimodal nature of proprioception, involving cutaneous, muscular and capsular information. Information registered in S1 is likely passed on to other regions of the parietal cortex body state is interpreted.(Wolpert et al. 1998)

The cerebellum also plays an important role in processing proprioceptive signals. Upper extremity feedback passes to the spinocerebellum and lateral cerebellar hemispheres via the cuneocerebellar and rostro-spinocerebellar tracts. These projections, relayed through the cuneate nucleus, reach the cerebellum as mossy fibers. Somatosensory signals from the periphery can also ascend to the cerebellum via the inferior olivary climbing fibers.(Bloedel 1973) The cerebellum is also interconnected with the cerebral cortex via the ventral posterior and ventral lateral nuclei of the thalamus. The cerebellum receives information from M1, S1 and secondary somatosensory (SII) cortices via mossy fibers from the pontine nuclei that infiltrate the lateral hemispheres.(Bloedel 1973; Clower et al. 2001; Middleton and Strick 2001) In addition, the motor cortex communicates with the cerebellum via olivary climbing fibers.(Bloedel 1973)

Most outputs of the cerebellum arise from the cerebellar nuclei. Those most important to volitional movements of the extremities are the interposed and dentate nuclei. Their projections target medullary and pontine nuclei, the thalamus leading to the cerebral cortex, and recursively innervate cerebellar regions as well.(Gardner and Thach 2000 Principles)

### *1.5 Proprioception and Motor Control*

Sensory and motor brain regions interact to produce skilled movement. Lesions to motor areas in the non-human primate brain can result in sensory deficits (Friel et al. 2005; Nudo et al. 2000) whereas sensory deficits can result in dystonia and motor control problems.(Byl et al. 1996; McKenzie et al. 2003; Sanger and Merzenich 2000) Permanent or temporary focal lesions induced in animals have provided us with clues to the interaction of sensation and movement in the cerebellum and cerebral cortex. Miall and colleagues (1987) temporarily impaired cerebellar structures of monkeys engaged in a continuous tracking task and found gross movement error. The error pattern suggested the cerebellum acts to update continuous movements, possibly by diminishing error-correction capacity based on proprioception. Removal of sensory cortex has been shown to result in disruption of fine motor skills and failure to acquire new skills.(Pavrides et al. 1993) Damage to the sensory pathways (thalamus, posterior limb of internal capsule, parietal cortex) directly impacts kinesthesia.(Derouesne et al. 1984; Groothuis et al. 1977; Sacco et al. 1987) Characterization of the differential effects of regional damage on a continuous tracking task adds to our understanding of the contributions of these areas to motor control and learning.

Some human studies have reported minimal proprioceptive influence on movement, relegating its function to assisting final targeting in slower movements.(Sittig et al. 1987; Sittig et al. 1985) These findings are at odds with investigations of individuals with large fiber neuropathy and absent kinesthesia who exhibit significant movement error when deprived of vision.(Cole and Sedgwick 1992; Rothwell et al. 1982) Gordon, Ghez and colleagues have extensively examined reaching movement of deafferented individuals. Absence of proprioception appears to result in failure to account for limb inertia.(Gordon et

al. 1995) Vision can substitute in the short term but ultimately the model of internal dynamics decays.(Ghez et al. 1995) Their findings have led to the conclusion that the proprioceptive system is critical for updating and maintaining an internal representation of limb dynamics and current position.(Ghez et al. 1990) Additionally, it has been shown that a deafferented individual can have difficulty generating predictive grip control of a novel object they are about to lift.(Nowak et al. 2004) In contrast, people with normal sensation appear to be able to use a forward model to predict necessary grip force based on the lift force planned in the outgoing motor command.

The participation of proprioceptors in novel task, multi-joint coordination has been examined as well.(Bevan et al. 1994; Cordo et al. 1994; Verschueren et al. 1999) Cordo and colleagues (Bevan et al. 1994; Cordo et al. 1994) have looked at proprioception in the control of multi-joint sequenced movements. In an elegant series of experiments subjects were asked to open their hand at a precise degree of elbow extension. When vibration was applied to the bicep tendon hand opening occurred earlier, as would be predicted if the subject perceived the elbow to be more extended.(Cordo et al. 1995b) These data suggest that proprioception can be used to trigger subsequent components of a motor pattern based on both angular position and distance traveled.

Introduction of neural noise through vibration is one method of approximating a damaged proprioceptive system because it stimulates primary spindle afferents that report both muscle length and velocity.(Roll and Vedel 1982) The preferential stimulation of intrafusal muscle fiber afferents makes this modality an attractive choice for the study of altered proprioception in healthy adults. Previous studies have used vibration to induce the perception of a passive antagonist muscle being stretched to a greater extent than in reality

with no effect on the agonist muscle.(Capaday and Cooke 1981; 1983; Gooney et al. 2000; Inglis and Frank 1990)

However, vibration is ultimately a peripheral disturbance and is limited in its ability to model pathologies of the central nervous system. People with central nervous damage such as stroke survivors frequently experience disruption of cutaneous and proprioceptive sensation. This is particularly true for strokes affecting the parietal lobe, thalamus and posterior limb of the internal capsule.(Lundy-Eckman 2002) Whereas peripheral receptors remain viable, central processing of the signals is damaged in the area of the stroke. Ghez and colleagues (1990) postulated that people with central nervous lesions would have motor planning disruptions similar to those experienced by those with peripheral sensory absence.

### *1.6 Sensation and Motor Learning*

Before one can produce skilled movement, patterns of muscle activity must be learned. That is, an individual must exhibit a relatively permanent change in the capability to perform the movement.(Schmidt and Lee 1999a) An extensive body of animal literature suggests that sensory cortex is important in acquisition of new motor skills. Sensory cortical structures appear to be important for novel movement acquisition (Bornschlegl and Asanuma 1987) but not necessarily the gross performance of movements in an existing skill repertoire, especially when the limb can be visualized.(Pavrides et al. 1993; Sakamoto et al. 1989) The arrangement of intracortical neurons from sensory cortex to M1 suggests that input from these sensory areas comes from areas associated with a movement of somatically related body parts.(Porter and Sakamoto 1988) Inputs may include proprioceptive neurons of the primary sensory cortex that respond to specific postures or directions of movement.(Costanzo and Gardner 1981; Gardner and Costanzo 1981)

Refinement of a skill in early training may be a result of the cortical processing of sensory input. According to this theory S1 “trains” the motor cortex through LTP.(Asanuma and Pavlides 1997) The actual outcome of a movement, conveyed via the afferent somatosensory system, is thought to be compared to the desired outcome and motor commands reinforced or discouraged.(Imamizu et al. 2003; Imamizu et al. 2000) Recently, this has been supported by data that suggest proprioception is integral to implicit learning of internal model dynamics.(Hwang et al. 2006b; Sober and Sabes 2003) Thoroughman and Shadmehr (1999) proposed that proprioceptive signals might constitute a template that guides an error-feedback response. This error-response could ultimately become the predictive forward model of activation that participates in generating appropriate motor commands.

Once a skill is learned the ventral lateral nucleus of thalamus (VL) appears to be key in maintaining performance.(Bornschlegl and Asanuma 1987) However, M1 cells can respond to VL input, but cannot be potentiated by the VL alone. This led to the suggestion that repeated stimulation from primary sensory cortex, such as might occur with repeated practice, could train the motor cortex to respond to VL input.(Iriki et al. 1989; 1991) Intracortical neurons from sensory cortex potentiating pyramidal cells in layers II and III could ultimately result in facilitated activation of corticospinal cells by the VL.(Kaneko et al. 1994) This proposed neural substrate provides for maintenance of existing skills following sensory cortical damage.

The cerebellum is another plausible candidate for error-based update of the internal model. It is active when a mismatch between forward model sensory prediction and actual sensory occurrence is detected.(Blakemore et al. 2001; Blakemore et al. 2000; Imamizu et al. 2000; Ramnani et al. 2000) Whether this activity is a mere signaling of the discrepancy or participates in the adaptation of the forward model is unknown. What is known is that

widespread cerebellar activation is refined and localized as a novel environment is learned.(Imamizu et al. 2000) Kitazawa and colleagues (1998) argue that error-related Purkinje cell firing contributes to refinement of future movements (i.e. learning).

### *1.7 Stroke*

Stroke is one of the leading causes of long-term adult disability in America and the world, with an annual incidence in the U.S. of over 700,000 cerebrovascular (CVA) events.(Association 2006) Two-thirds of those who experience lateralized weakness or paralysis after a stroke may have residual impairments of the upper extremity that interfere with daily activity.(Broeks et al. 1999) Depending on the location and size of the lesion, CVA sequelae can vary from sensorimotor impairments to cognitive impairments to memory loss.(Lundy-Eckman 2002) Hemorrhage or ischemic insult in the distribution of the anterior cerebral artery may result in, hemiparesis and hemisensory disruption, especially of the lower extremity, personality changes and disordered executive function. Middle cerebral artery (MCA) insult frequently presents with visual loss, language impairment, hemiparesis and hemisensory disruption especially in the upper extremity whereas posterior cerebral artery involvement often includes visual loss, hemiparesis, and hemisensory loss. Though rare, stroke affects the cerebellum producing discoordination and motor impairments. The focus of this dissertation work is on damage to the territory of the MCA and the cerebellum.

Lesion location may also differentially affect motor learning and rehabilitation potential. However, the examination of possible motor learning differences in those with stroke-related brain damage is still preliminary. In a study of a short-sequence tracking task, Winstein and colleagues (1999) found elevated error for those with stroke but no differences in learning or retention over time when compared to a control group. Specific regions of

stroke involvement in this study were unclear. Others have confirmed preserved implicit motor learning following stroke-related damage to sensorimotor cortex,(Boyd and Winstein 2003; Pohl et al. 2001) cerebellum (Boyd and Winstein 2004a) and the basal ganglia.(Boyd and Winstein 2004b; Vakil et al. 2000) Unable to precisely identify lesion location, Boyd and Winstein (2001) reported difficulty with implicit motor learning in groups with primarily parietal cortex, capsular and thalamic stroke.

Helping persons with stroke to improve function is one of the primary goals of the rehabilitation professional. However, common rehabilitative interventions are often not based on recent scientific literature but instead rooted in anecdotal report or trial-and-error.(Jette et al. 2003; Mikhail et al. 2005) Effective physical rehabilitation should be grounded in scientific evidence, including an understanding of motor control and learning following a CVA: one component of which is the elucidation of interaction between sensory and motor systems. This knowledge has the potential to help health care professionals tailor interventions and predict outcomes based on lesion location and the clinical presentation of the patient. Maximum intervention efficacy will ultimately require the consideration of affected neural structure and function in rehabilitation and a precise understanding of how neurologically intact individuals and stroke survivors function and learn new motor skills. Armed with this information, rehabilitation professionals might better individualize treatment strategies for each client. One intended outcome of this work is an eventual better understanding of the contribution of proprioceptive deficit the varied findings of motor learning following stroke.

## 1.8 Distinction of Experimental Design

The bulk of the internal model work that dominates the literature today has focus on task dynamics. These studies primarily utilized discrete, center-out reaching tasks. Learning studies in this paradigm have focused on development of the inverse model by introducing a force field for which the subject must learn to compensate.(Shadmehr and Mussa-Ivaldi 1994) Vercher and colleagues (2003) found that proprioception was important in adaptation of the internal model. While the environmental and internal dynamics must be learned, the task does not address a key component of skill performance: movement sequencing. Many movements in life require precisely timed, serial execution of motions, such as pitching a baseball. Such tasks consist of multiple linked movements and changes in limb velocity and dynamics, and it may be that internal models exist for both the kinematics and kinetics of a skill.(Krakauer et al. 1999)

A whole-arm continuous tracking task was selected for the present research as a departure from much of the previous work utilizing discrete, familiar or single-joint reaching movements. Few daily activities are carried out with a single joint in isolation. Rather, many skills are the product of sequential coordination of limb segments in a distinct pattern. For example, to pitch a baseball requires several weight shifts, changes in limb velocity, and accurate timing to be executed effectively. Furthermore, the continuous tracking task likely mimics the environment in which a person would implicitly acquire a skill with multiple degrees of freedom: tracking a sequence of limb movements predicated on previous limb position with a clear goal, maintaining proximity to the target. Consideration of complex movements, as continuous tracking might be considered, is essential for the development of accurate models of motor control.(Cordo and Gurfinkel 2004; Wulf and Shea 2002)

Additionally, in many previous studies the subject was allowed to practice the task prior to the application of vibration (Bernier et al. 2006; Cordo et al. 1994; Pipereit et al. 2006) which can result in biased performance toward the practiced skill.(Bevan et al. 1994) Therefore inferences regarding learning are questionable. The protocol employed in this dissertation utilizes minimal task familiarization and a retention test to separate transient performance improvements from more permanent motor learning.(Salmoni et al. 1984)

Finally, this dissertation presents work both with the exogenous alteration of proprioception on healthy adults as well as those with central nervous system damage that impacts proprioception. When reporting on maintenance of body movement representation, Ghez and colleagues (1990) confirmed and solicited further study in this area when they posited that deficits in “deafferented patients will ... have analogs in ... patients with central lesions.” As will be reported in the following chapters, peripheral and central proprioceptive disruption have different effects on learning.

### *1.9 Significance of the Presented Work*

Despite advances in early intervention, half of those individuals with chronic stroke experience significant loss of upper extremity function including the loss of sensation.(Carey 1995) Functional recovery is a primary concern for the stroke survivor, and these individuals look to rehabilitation scientists and clinicians to restore their functional ability. Uncertainty about how the brain recovers from, and compensates for, stroke-related damage has lead to attempts to rehabilitate patients through a variety inadequately researched methods.

The present study contributes to a more complete understanding of the neurological basis of skill learning. In the long-term, these efforts will lead to the development of scientifically grounded rehabilitation approaches, specifically targeted towards enhancing

functional recovery. Further, it may lead to a reconceptualization of what constitutes “best” care for individuals with disrupted proprioception after stroke: especially considering sensation is receiving increasing interest as a therapeutic target.(Davies 2000; Woldag and Hummelsheim 2002)

In addition to informing rehabilitative care, the presented work can be viewed from a theoretical perspective. Much of the existing literature has been devoted to identifying regions of the brain that participate in skilled movement. However, the study of motor and premotor cortical activation predominates. This has occurred despite a growing body of literature suggesting the close association between motor and sensory systems.(Friel et al. 2005; Nudo et al. 2000) The work presented in this dissertation examines the importance of sensation in motor skill acquisition and contributes to our understanding of the role of proprioception in motor sequence learning both in neurologically intact adults and after brain damage.

#### *1.10 Specific Aims and Statement of Hypotheses*

The long-term goal of this project is to characterize the contribution of intrinsic somatosensory feedback to motor learning both in healthy and pathologic populations. Three central aims directed this research.

**1. Determine the effect of disrupted sensory feedback on motor sequence learning (Chapter 2 & 3).** If proprioception is important for motor learning of a continuous task, then alteration of proprioceptive sensation should deleteriously impact performance and learning of a continuous sequence. It was hypothesized that if proprioception is critical for the development of the internal model, inappropriate proprioceptive signals during acquisition would disrupt motor learning. This would be evident in poorer retention of target regularities

for a repeated tracking segment for groups who receive vibration versus those who did not. Surprisingly it was found that individuals learned a repeated movement sequence despite altered proprioception. In a follow up experiment the contribution of vision to developing an internal model for a motor sequence was investigated. Results suggested both the manual and oculomotor systems made improvements in tracking.

**2. Establish whether proprioceptive sensation is critical for continuous motor sequence learning in a chronic stroke population (Chapter 4).** If the neural structures conveying and processing somatosensory information were important for motor learning, damage to those structures should negatively impact learning of a new motor skill. It was hypothesized that if the sensory cortex were necessary for learning a new motor skill, lesions of sensory cortex, thalamus, or the associated white matter tracts such as the posterior limb of the internal capsule would result in less retention of target sequence regularities for a repeated tracking segment than the control group. Furthermore, it was hypothesized that the extent of the proprioceptive deficit would be predictive of target segment retention. Indeed, it was found that proprioceptive integrity was closely related to sequence-specific improvements in tracking over the course of practice.

**3. Ascertain the effect of cerebellar damage on the use proprioceptive sensation for motor sequence learning (Chapter 5).** The cerebellum likely plays an important role in movement-error assessment based on sensory information. Owing to its role in error detection and motor update, we hypothesized that individuals with damage to cerebellar structures would demonstrate impaired sequence learning of a motor skill when limited to use of proprioception to control motor performance and learning. It was found that some

individuals with cerebellar pathology demonstrated a preserved capacity for motor sequence learning, similar to a healthy cohort. However, these same participants displayed poorly timed movements as previously reported. Other individuals, with generally much larger areas of infarct did not demonstrate sequence-specific learning and appeared to attempt a strategy of movement anticipation. These individuals also demonstrated severe proprioceptive and motor deficits. These results suggest that the area of cerebellar damage may be critical the maintenance of somatosensory feedback-based motor learning.

In sum, the work presented in this dissertation has or will lead to the submission of 4 unique manuscripts that consider 1) the impact of altered afferent proprioception on motor learning in healthy people (to be submitted to Behavioral and Brain Functions), 2) of the interaction of visual and manual motor systems in continuous sequence learning (to be resubmitted to Human Movement Science), 3) the effect of centrally disrupted proprioception after stroke (submitted to Experimental Brain Research), and 4) characterizing the importance of the cerebellum in processing proprioception information and updating the internal model (to be submitted to the Neurorehabilitation and Neural Repair).

Figure 1.1 The Internal Model

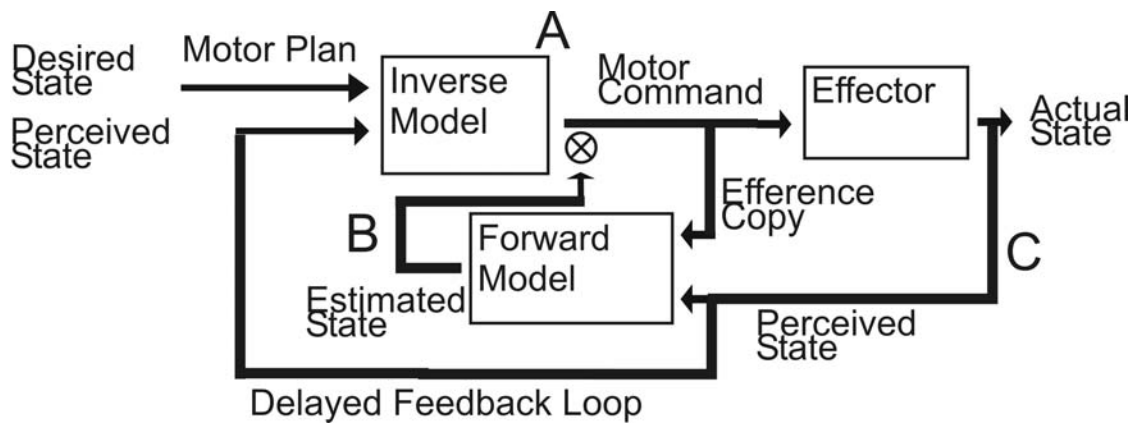

The internal model consists of the forward and inverse models. The inverse model issues motor commands (A) based on the desired action or updates commands based on sensory consequences predicted by the forward model (B). As reported later, noise introduced into the estimate of perceived state by vibration at C can be used to examine the role of sensation on motor learning. Additionally, lesions to brain regions may impact any process upstream of the effector. Adapted from Vercher et al. (2003) and Kawato (1999).

## **Chapter 2 Preface**

In Chapter 1, previous work on proprioception and motor learning was presented. This included theoretical constructs (i.e. the internal model) that depend in part on the use of afferent information for their development and maintenance. Having established this foundation, Chapter 2 explores the impact of altered peripheral afferent information on motor learning. One commonly used manner of investigating afference in the internal model is to change somatic information being supplied to the CNS: for example altering feedback at location C in Figure 1.1. This was accomplished through the application of vibration to healthy young adults during skill practice.

## **Chapter 2**

### **Motor Sequence Learning Occurs Despite Altered Visual and Proprioceptive Feedback**

Vidoni, E. D., Boyd, L. A. Motor Sequence Learning Occurs Despite Altered Visual and Proprioceptive Feedback. (to be submitted to the Behavioral and Brain Functions, Jan. 2008)

## *2.1 Abstract*

Recent work has demonstrated the importance of proprioception for the development of internal representations of the forces encountered during a task. Evidence also exists for a significant role for proprioception in the execution of sequential movements. However, little work has explored the role of proprioceptive sensation in the learning of continuous movement sequences. Here we report that the repeated segment of a continuous tracking task can be learned despite altered arm proprioception and severely restricted visual feedback regarding motor output. Healthy adults practiced a continuous tracking task over 2 days. Half of the participants experienced vibration that altered proprioception of shoulder flexion/extension of the active tracking arm (experimental condition) and half experienced vibration of the passive resting arm (control condition). Retention testing was conducted on a separate day to assess motor learning. Regardless of vibration condition, participants learned the repeated segment demonstrated by significant improvements in accuracy for tracking repeated as compared to random continuous movement sequences. These results suggest that with practice, participants were able to use other available afferent information to overcome initial interference of tracking ability related to altered proprioception and restricted visual feedback to learn a continuous motor sequence. Learning occurred despite initial interference of tracking.

## *2.2 Introduction*

Current evidence suggests an important role for afferent sensation and proprioception in learning and execution of skilled motor behaviors. During motor learning, proprioceptive feedback may form a template for comparison to a motor plan; perhaps through the tuning of electromyographic activity over practice in a similar manner to muscle spindle feedback based adaptation.(Thoroughman and Shadmehr 1999) Extending these findings, Hwang and Shadmehr noted that computer simulations of muscle spindle-based learning closely matched human learning of a reaching task in a force field.(2005).

Several studies have documented the relationship between proprioception and motor learning using both healthy participants and those with disrupted sensation. In particular, previous work has demonstrated the importance of proprioception in accounting for the internal and external forces encountered by the limb during movement.(Pipereit et al. 2006; Vercher et al. 2003) Using the classic clinical model of absent proprioception in human participants, Gordon et al. (1995) examined individuals with deafferentation due to large fiber neuropathy as they made discrete reaching movements without vision of the hand. The individuals in their study could not accurately reach or directionally correct movements in response to their own limb inertia. Though the data reported by Gordon et al. suggest that proprioception is key to maintaining a representation of the body's own dynamics, they do not consider whether proprioception has an essential role in motor sequence learning.

Most past work has investigated the role of proprioception in generating accurate discrete movements during a single session, with little work focused on the importance of proprioception during motor sequence learning. Limited consideration of the role of proprioception during motor learning is illustrated by the common practice of allowing participants to familiarize themselves with (i.e., practice) the task prior to data

collection.(Bernier et al. 2006; Bevan et al. 1994; Pipereit et al. 2006) Though this creates a controlled environment for investigating the role of proprioception in short-term motor performance, it confounds our understanding of motor learning by pre-training participants on the task. This issue was inadvertently highlighted by Bevan and colleagues (1994) who anecdotally reported that participants demonstrated the best performance for the tasks that they initially practiced. Further, experimental tasks designed to study the role of proprioception in motor performance have often included typical daily behaviors such as reaching; in these cases participants likely already have a well learned motor plan.(Gordon et al. 1995) As such we continue to know little about how proprioception contributes to the formation of motor plans, rather than simply their execution. In summary, at present the importance of intact proprioception for motor sequence learning remains unclear.

Vibration can predictably shift perception of movement as originally demonstrated by Goodwin and colleagues (1972) who cataloged its illusory effects on sensory perception. This effect has been repeated and further qualified (Capaday and Cooke 1983; Cordo et al. 1995b; Forwell and Carnahan 1996; Pipereit et al. 2006; Roll and Vedel 1982; Vedel and Roll 1983; Vercher et al. 2003) making vibration a useful experimental tool. Vibration produces the illusion of movement by stimulating primary spindle fiber afferents.(Roll and Vedel 1982) Furthermore, vibration masks the report of accurate afferent information regarding antagonist muscle stretch via stimulating primary spindle fiber afferents (Vedel and Roll 1983) and influencing muscle activation patterns.(Capaday and Cooke 1983) In light of these findings, in Experiment 1 we characterized the impact of vibration on proprioception using a limb position matching task. Study participants attempted to continuously match the position of a vibrated arm to that of an unvibrated arm as it moved through a 30 second motor sequence while vision of both arms was prevented. We discovered that vibration predictably

altered proprioception and caused participants to overestimate motion in the limb-matching task.

After confirming that our method of vibration alters proprioception, we applied vibration during practice of a continuous tracking task and examined the effect of shifted limb position sense on motor sequence learning. We hypothesized that if intact proprioception was essential for motor sequence learning, altering this feedback during practice would be evident in accuracy measures at retention testing. Alternately, it is possible that the normal motor system is flexible and robust enough to facilitate sequence learning even with altered proprioception. The possibility that individuals can demonstrate motor sequence learning even when proprioception is altered is important to neuroscientists and clinicians alike. Knowledge of the significance of accurate proprioceptive information during motor sequence learning may facilitate the genesis of novel models that predict skill acquisition. In turn, these data may be used to generate new therapeutic interventions for the management of diseases such as stroke that commonly impair proprioceptive sensation.

### *2.3 Experiment 1*

Vibration has previously been used to alter proprioception during upper extremity movement to demonstrate its role during 1) the execution of previously learned movements (Cordo et al. 1995a; Forwell and Carnahan 1996) and 2) the control of the limb against external forces. (Pipereit et al. 2006; Vercher et al. 2003) To verify this effect, in Experiment 1, we quantified the impact of vibration delivered to the upper arm, adjacent to the shoulder during both passive and active arm movements.

The shoulder has both single- and multi-joint muscles making it an optimal location to deliver a generalized vibratory stimulus for experimental investigations. Previous studies

have applied shoulder muscle vibration during whole arm movements to examine motor performance.(Forwell and Carnahan 1996) Because our experimental task required shoulder flexion and extension movements to push and pull a frictionless lever mounted at shoulder height, application of vibration to the proximal arm musculature was ideal. Evidence from differences in the in arm position during limb matching in Experiment 1 demonstrated that vibration altered proprioception.

### *2.3.1 Methods*

#### *Participants and Apparatus*

Fifteen healthy adults (8 males, 7 females; mean age 33.1 [range 26-46]) with no reported diabetes, or upper extremity muscular or sensory impairments provided institutionally approved informed consent. Participants engaged in a limb-position matching task (van Deursen et al. 1998) modified for the upper extremity. Two near-frictionless, horizontally-mounted levers were positioned at shoulder level to allow participants to grasp one in each hand (Figure 2.1 a and b). The levers were attached to potentiometers that registered angular displacement.

Three eccentrically loaded motors within a cuff provided the vibratory stimulus. The cuff was secured to the dominant arm, as identified by the Edinburgh Handedness Inventory, (Oldfield 1971) with an elastic wrap at the level of the deltoid insertion. The vibrating motors were positioned on the anterior, lateral and posterior aspects of the upper arm. In this manner aspects of the biceps brachii, triceps brachii and deltoids were vibrated.

Vibration-induced movement illusion occurs over a wide range of stimulation frequencies, but most effectively at 50-100Hz.(Sittig et al. 1987; Vedel and Roll 1983) To avoid the possibility that participants would accommodate to vibration, thus potentially

limiting its impact on limb position sense, we systematically varied the frequencies of vibration (50, 60, 70, 80Hz) across trials; for experiment 1 two trials were performed at each frequency in a pseudorandomized order. The same 16 random movement patterns were tested for each condition.

### *Experimental Conditions*

To test whether vibration influence proprioceptive sensation during both passive and active movement, separate trials were performed during which the one arm was moved by the experimenter and the participant matched the opposite arm. Vibration was introduced in half the trials. Subjects performed this matching task in separate conditions where vibration was applied to the passive, experimenter-driven arm (PV) and then to the actively matching arm (AV). For example, a right-handed participant would be fitted with the vibration cuff on the right upper arm. In the PV condition the examiner would guide the right arm and the individual would match those movements with the left arm for 8 trials without vibration and 8 trials with vibration. In the AV condition, the examiner would guide the left arm and the individual would attempt to match with the right (Table 2.1). Thus we were able to compare typical limb position matching ability to that when vibration was applied either to the active, matching limb or to the passive, driven limb. To avoid potential vibration after-effects, non-vibration trials were always performed prior to vibration trials.

### *Outcome Measure*

The position of each lever and thus the excursion of each arm was sampled at 40Hz and raw position data were smoothed using a 100ms moving average. To demonstrate and quantify the effect of our vibratory manipulation, the perceptual shift stimulated by vibration was indexed by the ratio or gain between the actively matching and driven arm movement

amplitudes<sup>2</sup>. Gain measures over 1.0 indicate movement amplitude of the active arm was greater than that of the driven arm. Gain measures during no vibration trials were averaged for each subject. Based on previous work,(Goodwin et al. 1972; van Deursen et al. 1998) we predicted that vibration delivered to the passive experimenter-driven arm (PV condition) would result in the perception of driven arm movement as greater than in reality. In this case, individuals would over-estimate the magnitude of active limb motion required to match the position of the other arm. The opposite was expected when vibration was applied to the arm with which the participant actively tracked (AV condition)

Planned pairwise, one-tailed t-test comparisons of vibration and no-vibration trials for both AV and PV were tested at  $\alpha=.025$ .

### *2.3.2 Results*

We hypothesized that if our method of vibration resulted in altered position sense, then gain measures in the PV condition would be greater with vibration on compared to vibration off. We also expected that gain measures in the AV condition would be less than in the no vibration condition. As can be seen in Figure 2.2, vibration to the shoulder musculature resulted in changes in perceived upper limb movement consistent with our expectations. Pairwise t-testing revealed statistically significant differences between vibration and non-vibration trials for both the PV ( $p=0.016$ ) and AV ( $p=0.003$ ) conditions. Anecdotally, some participants reported feeling vibration both proximally in the shoulder and neck as well as distally in the elbow and “tingling” into the wrist and hand.

---

<sup>2</sup> Gain = RMS position of arm / RMS position of driven arm, Root mean square (RMS) =  $\text{SQRT}(\sum x_i^2 / n)$  where  $x_i$  = limb position

### *2.3.3 Discussion*

These data demonstrate that vibration to the upper extremity at frequencies between 50 and 80Hz resulted in altered position sense that did not accurately reflect true limb position. Importantly, every 0.1 difference in gain (Figure 2.2) translates into an average 3cm difference between hand positions at the transition between flexion and extension movements. As our participants demonstrated vibration-induced gain differences of .19 in the AV condition and .13 in the PV condition vibration substantially altered tracking accuracy.

Based on our findings, and other recent work by Bock et al. (2007) outlining the problematic and invasive nature of other methods of sensory disruption (i.e., ischemic cuffs, peripheral nerve blocks) we elected to use the same method of vibration in experiment 2 to disrupt proprioception throughout practice of a continuous motor tracking task. This approach allowed us to ascertain the impact of altered proprioception on motor sequence learning.

## *2.4 Experiment 2*

### *2.4.1 Methods*

#### *Participants*

Twenty-five healthy adults (9 males, 16 females; mean age 27.0 [range 22-43]) with no reported diabetes or upper extremity muscular or sensory impairments provided informed consent in accordance with institutional guidelines. Three of these individuals participated in experiment 1. The dominant arm, as determined by the Edinburgh Handedness Inventory,(Oldfield 1974) was used for task practice.

### *Tracking Task*

Seated in front of a computer monitor, participants engaged in a continuous tracking task of a target moving in a sine-cosine wave pattern (Pew 1974; Wulf and Schmidt 1997) using their dominant arm: 23 right-handed, 2 left-handed. The same lever set-up used in experiment 1 (Figure 2.1 a and b) was moved with shoulder flexion and extension to move an on-screen cursor vertically up the screen (shoulder flexion) or down the screen (shoulder extension); naturally elbow extension followed shoulder flexion and elbow flexion accompanied shoulder extension in a parasagittal plane. The target appeared as a white box and participant movements were represented as a yellow circle cursor. The lever apparatus necessitated 31cm of angular excursion over a maximum of 60° to accurately track the waveform and each participant was easily able to move through this range of motion. As in experiment 1, lever position sampling was performed at 40Hz. All stimuli were presented at 40Hz using custom software developed on the LabView platform (v. 7.1; National Instruments, Austin, TX).

The pattern of target movement was predefined according to a method modified from Wulf and Schmidt.(1997) For each 33s trial a unique target wave was assembled from one 3s baseline (to allow participants to orient their arm to task midline) and two 15s component sine-cosine wave segments, or “epochs.” In each tracking trial, participants were exposed to a novel random epoch and an epoch that contained a repeated sinusoidal sequence (Figure 2.1c). To avoid order effects presentation of the repeated sequence epoch randomly occurred as the first or second segment. The same presentation order was employed for every participant.

### *Experimental Design*

Upon enrollment, individuals were randomly assigned to either the control (CTL) group that received vibration to the non-hand-dominant (passive, non-tracking) arm, or to the proprioception altered group (DIS) that received vibration to the hand-dominant (active, tracking) arm. To limit the possibility that task learning that might occur with pre-practice, no task familiarization period was provided. Prior to acquisition, participants were instructed to track the target as accurately as possible by controlling the position cursor with shoulder flexion / extension movements of the lever.

Individuals practiced the tracking task 50 trials a day for two days (Table 3.2). During these training days, vibration was applied according to group assignment. The possibility of accommodation to the vibratory stimuli was avoided by randomly varying the frequency of stimulation after each trial; frequencies of 50, 60, 70 and 80Hz were randomly arranged and delivered in the same order for all participants.

On a separate third day, participants returned for 10 retention test trials. The upper arm was fitted with a vibrating cuff in the same manner as Experiment 1, according to group designation. However, to examine the impact of proprioception on motor sequence learning without the transient effects of altered proprioception contaminating the data, at retention testing the cuff was fitted but no vibration was applied for 10 trials.

The possibility that participants might use vision to compensate for altered proprioception was limited by preventing vision of the arms and severely restricting visual feedback of the cursor position. Draping was used to prevent vision of the arms throughout the entire study for both groups. The drape was placed over, but did not come in contact with, the participant's upper body to avoid the possibility that brushing against it would provide cutaneous sensory cueing. Additionally, over the first 20 practice trials, visual

feedback regarding lever position was faded. We determined that initially (blocks 1 and 2 of practice) some visual feedback of cursor position was necessary for participants to understand the task; however, this feedback was removed quickly (our schedule of fading was similar to that reported by Winstein and colleagues (1994)) and blocks where visual feedback was present were not included in data analyses. Past work investigating continuous sequence production demonstrated that when visual feedback for cursor movements was delivered at 500ms/1sec or less it actually disrupted the use of visual feedback to guide movement.(Kao 1976) Thus, in instances where visual feedback is less than or equal to 500ms/1sec, Kao showed that its brevity rendered it virtually useless for guiding hand-controlled cursor movements. Applying this finding, we linearly reduced the amount of time the position cursor appeared beyond the threshold reported by Kao. This ensured that visual information could not be used to continuously guide movement or influence motor learning. In the present task, arm position information was faded from continuous on trial 1 (block 1), to a 200ms position cursor presentation every 2s by trial 19 (block 2) and kept at this level for the remainder of the study. To maintain motivation for this difficult task and encourage accurate tracking, participants were provided summary feedback after each trial during acquisition as a percentage of time the position cursor spent within a 10° bandwidth of the target. Because summary feedback regarding overall tracking accuracy was provided only for motivational purposes, did not contain sufficient information to alter performance, and was not explicitly manipulated across the groups we also provided this information at retention.

### *Outcome Measures*

The primary outcome measure was root-mean-squared error (RMSE)<sup>3</sup> calculated as the area difference between target and participant position separately for random and repeated sequence epochs. RMSE from each 10 consecutive trials was averaged to represent 1 block of sequence performance during the initial two days of training, and learning at retention. Box-plot analysis revealed that one individual in the DIS group performed poorly enough to be considered an outlier when compared to the group during practice. This participant was excluded from further analysis.

Because proprioception has previously been related to both spatial and temporal aspects of movement sequences (Bevan et al. 1994; Cordo et al. 1994) we further explored whether altered proprioception would differentially impact spatial and / or temporal learning the repeated sequence using a time series analysis.(Boyd and Winstein 2004a) This was accomplished through cross correlation (stock signal processing function; Matlab 7.0.4, The Mathworks, Natick, MA).(Day and Marsden 1982) In the time series analysis the position signal of each trial was repeatedly correlated with the target signal while the time delay was successively increased between the two signals. The time lag corresponding to the greatest correlation index was taken as a measure of temporal tracking accuracy. Original, tracking position data were shifted by this lag and RMSE was recalculated to produce a “lag-corrected” measure of spatial accuracy. The distance that data were shifted to achieve the lag-corrected measure represents time lag of tracking. Examples of real-time and lag-corrected tracking accuracy from individuals in both groups can be seen in Figure 2.3.

---

<sup>3</sup> RMSE = SQRT( $\sum(x_i - X_i)^2 / n$ ) where  $x_i$  = probe position,  $X_i$  = target position

### *Statistical Analyses*

First, to ensure that no baseline motor control differences biased group performance, a one-way ANOVA of Group (DIS, CTL) at Block 1 using random epoch RMSE at the dependent measure was conducted. Next, the first and last blocks of each day of training were used to represent change in behavior associated with skill acquisition. Tracking performance was assessed via three-way ANOVA (Epoch (random, sequence) x Block (3, 5, 6, 10) x Group (DIS, CTL) with repeated measures correction for Epoch and Block. RMSE, time lag and time lag corrected RMSE served as dependent measures. Sequence-specific learning was assessed using the retention test with two-way ANOVA (Group (DIS, CTL) x Epoch (random, sequence)) with repeated measures correction of epoch for each of our dependent measures. To separate change in tracking associated with improved motor control or non-specific learning from more permanent changes in behavior as a result of sequence-specific learning for the repeated epoch we statistically compared performance of random versus repeated sequences. All analyses were tested at  $\alpha=.01$  to protect against Type I error. A Greenhouse-Geisser correction was used where appropriate.

### *2.4.2 Results*

#### *Continuous Tracking During Acquisition Performance*

At the beginning of training in block 1, before visual feedback of the position cursor was faded, performance for the DIS and CTL groups for random sequence were similar, ( $F(1,22)=1.079$ ,  $p=.31$ ). Because error during tracking of random sequences indexes motor control or non-sequence-specific task performance lack of an initial group difference suggests that there were no baseline effects that might shift our findings.

Block 3 represents the first time-point where visual feedback was consistently below levels considered useful for assisting continuous tracking; it was therefore considered the first block of practice for data analyses purposes. Visual inspection of the data shows that over the course of the two training days all participants improved (decreased) sequence tracking error as compared to random tracking performance (Figure 2.4). This was confirmed via a [three-way ANOVA (Epoch (random, sequence) x Block (3,5,6,10) x Group (DIS, CTL)) with repeated measures correction of Epoch and Block. In this analysis, the acquisition of sequence-specific knowledge across practice is evident in the significant Epoch x Block interaction ( $F(3,66)=15.772, p<.001$ ). However, no Group effect was evident.

#### *Temporal versus Spatial Performance*

Decomposing performance into spatial and temporal dimensions revealed that altered proprioception impacted tracking accuracy rather than the time lag of tracking. Lag-corrected RMSE, which indexes spatial accuracy, trended toward being worse for the DIS group (Block x Group interaction ( $F(3,66)=3.606, p=.018$ )) during acquisition performance. This finding may relate to the initially worse spatial tracking ability of the DIS group (see Figure 2.5). In addition, an Epoch x Block ( $F(3,66)=10.34, p=.001$ ) interaction revealed that tracking accuracy for the repeating sequence improved more with practice than did random epoch tracking.

Time lag of tracking did not appear to be changed by altered proprioception. This was evident in the ability of both groups to similarly reduce the time lag of their tracking with practice as shown by an Epoch by Block interaction ( $F(2.167, 47.669)=5.564, p=.006$ ; Figure 2.6).

### *Continuous Tracking at Retention*

At the delayed retention test on day 3 both groups demonstrated sequence-specific learning of task regularities that allowed them to maintain improved tracking ability for the sequence epoch when compared to random performance. This was confirmed with a two factor ANOVA (Group (DIS, CTL) x Epoch (random, sequence)) where only the main effect of Epoch reached significance ( $F(1,22)=21.305, p<.001$ ). This finding was echoed in the time series analysis. Both groups showed a decreased error for the sequence epoch for temporal ( $F(1,22)=25.32, p<.001$ ) and spatial components of tracking ( $F(1,22)=16.310, p=.001$ ).

### *2.5 General Discussion*

The purpose of this study was to examine the impact of altered proprioception in motor sequence learning of a continuous tracking task. A large body of literature demonstrates that information regarding body state is crucial for motor control.(Cordo et al. 1994; Ghez et al. 1995; Ghez et al. 1990; Gordon et al. 1995; Vercher et al. 2003) In this study, we sought to determine whether this was also the case for motor sequence learning. In the past, Rothwell and colleagues (1982) suggested that motor learning might be deleteriously impacted by absent proprioception via their case report of a deafferented individual. In this case, the authors reported that learning new, complex sequences of hand movements was difficult when deafferentation was present. We sought to extend these findings to determine if similar negative effects would be present for continuous motor sequence learning when proprioception was shifted by vibration and discovered that a robust learning system was able to overcome initially disturbed tracking performance.

To our knowledge the present study represents the first experimental investigation of the impact of altered proprioception on continuous motor sequence learning. The experimental design employed for the current work differs from previous studies in several important ways. First, we used a continuous tracking task that required participants to use their entire upper extremity to produce movement. It has been suggested that investigation of complex movements (i.e. those that involve more degrees of freedom or greater muscle activation) are critical for our understanding of motor learning and behavior (Cordo and Gurfinkel 2004; Wulf and Shea 2002) and our task met these criteria. Previous studies of proprioception have almost exclusively employed discrete, reaching-type tasks for which participants likely already have a motor plan. Our use of a continuous motor sequencing task allowed us to examine learning of a novel tracking sequence. Finally, we engaged individuals in two days of practice and a separate, delayed, retention test. In this manner learning versus performance improvements were clearly differentiated.(Salmoni et al. 1984) Because no prior studies of the role of proprioception have employed a retention test design it has not been clear whether altered proprioception would deleteriously impact motor learning.(Bernier et al. 2006; Hwang et al. 2006b)

We hypothesized that if veridical proprioceptive sensation was essential for sequence learning, untrustworthy proprioceptive information would diminish both acquisition and retention of the repeated motor sequence. We discovered that the opposite was true; all participants were able to learn sequence-specific regularities as compared to random epoch performance regardless of the presence of vibration. The finding that individuals can learn to accurately and continuously track a repeating sequence even when vibration was applied to the arm being used suggests that accurate and intact proprioception are not absolute prerequisites for encoding and consolidating movement regularities. We found that, despite

initially larger spatial error, the group that practiced with altered proprioception (DIS group) was able to improve both spatial and temporal tracking error. This finding was facilitated by our experimental design; had we stopped data collection earlier in the experiment as past work has done we would not have noted the positive effect of task practice in overcoming altered proprioceptive feedback.

Cordo and colleagues (1995a; 1994) have suggested that the dynamic position and velocity information supplied by proprioceptors may be important for the execution of movement sequences. Based on this, we posited that proprioception would also be critical for learning the spatio-temporal regularities of a repeated continuous sequence. Rather, we found that accurate proprioceptive information was not essential for learning our experimental task. In fact, we noted that the worse performance of those with altered proprioception was transient and not evident at retention.

Simply becoming aware of the repeating sequence is another possible reason that the DIS group was able to learn the continuous tracking task. It is certainly possible that observation of target movement was sufficient to stimulate learning. Indeed, sequence learning has been demonstrated following stimulus observation alone (Bird et al. 2005) especially when individuals attend to the task.(Howard et al. 1992; Willingham and Goedert-Eschmann 1999) In accordance with these findings we cannot rule out the possibility that untrustworthy proprioception was compensated for by paying greater attention to target motion.

Another plausible explanation for our finding that altered proprioception did not diminish learning may be that accurate afferent sensation from more distal segments of the arm might have been preserved and exploited. We cannot totally rule out this possibility with the present experimental setup. Single joint elbow muscles as well as wrist and finger

musculature, joint and cutaneous afferents were possibly spared from vibratory disruption (though several subjects reported “numbness and tingling” into the forearm and wrist). Furthermore, secondary spindle afferents appear to be relatively insensitive to vibration (Vedel and Roll 1983). The central nervous system could have preferentially attended to these signals for information regarding performance.

However, we suggest that the hypothesis outlined above cannot completely explain our results because this same “unaltered” afferent information did not overcome vibration-induced changes as shown by the limb-position matching task in experiment 1. Additionally, tracking error was elevated for participants in the DIS group early in training as compared to the control group (random epochs, blocks 3 and 5). These findings supply convergent evidence that vibration was disruptive to at least spatial motor control. Based on the early practice and limb position matching data of Experiment 1, it appears that vibration induced at least some shift in the afferent feedback from the shoulder and elbow spanning musculature to the central nervous system that altered motor output. More importantly, initially disrupted motor output was normalized by practice, allowing motor learning to occur.

It has been previously noted that vision is critical when proprioceptive sensation is diminished or absent.(Cole and Sedgwick 1992; Rothwell et al. 1982) Ghez et al. (1990) reported that individuals with large fiber sensory neuropathy improved their aim on discrete reaching tasks when able to visualize arm position before movement. To explore the contribution of proprioception without the confound of visual feedback, we reduced visual information available to the participant via several controls. First, we occluded vision of the arm via draping. Next, we quickly faded feedback regarding cursor position over the first 20 trials to an intermittency exceeding that which Kao (1976) cited as being disruptive to continuous tracking. However, we chose to preserve some visual feedback to reduce

cumulative error which might have obscured improved motor control associated with learning (Hocherman and Levy 2000) by displaying the arm position cursor for 200ms at 1800ms intervals. Though unlikely, it is possible that even this minimal visual information may have allowed participants to evaluate their performance and adjust accordingly in the absence of trustworthy proprioceptive feedback.

Our finding of preserved continuous sequence learning despite restricted visual feedback and altered proprioception reflects the dynamic and robust nature of a motor learning system that is able to compensate for inaccurate afferent information through redundant physiological and cognitive systems. One or some combination of all of the mechanisms proposed above may have facilitated learning for participants in this research. Though these findings do not directly support our original hypotheses that altered proprioception would disrupt motor sequence learning, they are not without precedent. Skill learning has been reported in dorsal rhizotomized monkeys.(Taub et al. 1966; Taub et al. 1978) The juxtaposition between our findings and Taub et al.'s are in contrast to reports by others,(Pavrides et al. 1993; Sakamoto et al. 1989) who have reported disruption of skill learning following sensoricortical damage. These seemingly contradictory results may be a function of the difference between central and peripheral neural damage/disruptions. It remains to be seen if those with chronic sensory impairment resulting from damage to sensory cortical or thalamic regions have difficulty learning new motor skills. Future work should consider this possibility in persons with medical conditions characterized by reduced proprioception.

## Chapter 2 Tables and Figures

	Active Vibration		Passive Vibration	
	Left	Right	Left	Right
Side Vibrated		X		X
Active Matching Arm		X	X	
Passive Driven Arm	X			X

\*Assuming a right hand-dominant individual

Table 2.1 Limb Position Matching Conditions

Test conditions for a right handed subject in the limb position matching task, experiment 1. The vibrating cuff was applied to the dominant upper limb (in this case, the right shoulder). Then, each arm was moved, or “driven”, by the experimenter, while the participant actively matched those movements with the opposite arm. In this manner, the right arm was vibrated both while it was actively matching (AV condition) and while it was passively driven (PV condition).

<u>Day</u>	Blocks	Trials	Vibration	Visual Feedback
Training Day 1	1-2	20	Yes	Faded
	3-5	30		200ms / 2s
Training Day 2	6-10	50	Yes	200ms / 2s
Retention Day 3	11	10	No	200ms / 2s

Table 2.2 Testing Schedule and Conditions

Each subject completed three (3) days of training and retention testing. Visual and proprioceptive conditions followed this schedule. Participant groups (CTL, DIS) differed only according to the side on which vibration was applied.

Figure 2.1 Experimental Setup.

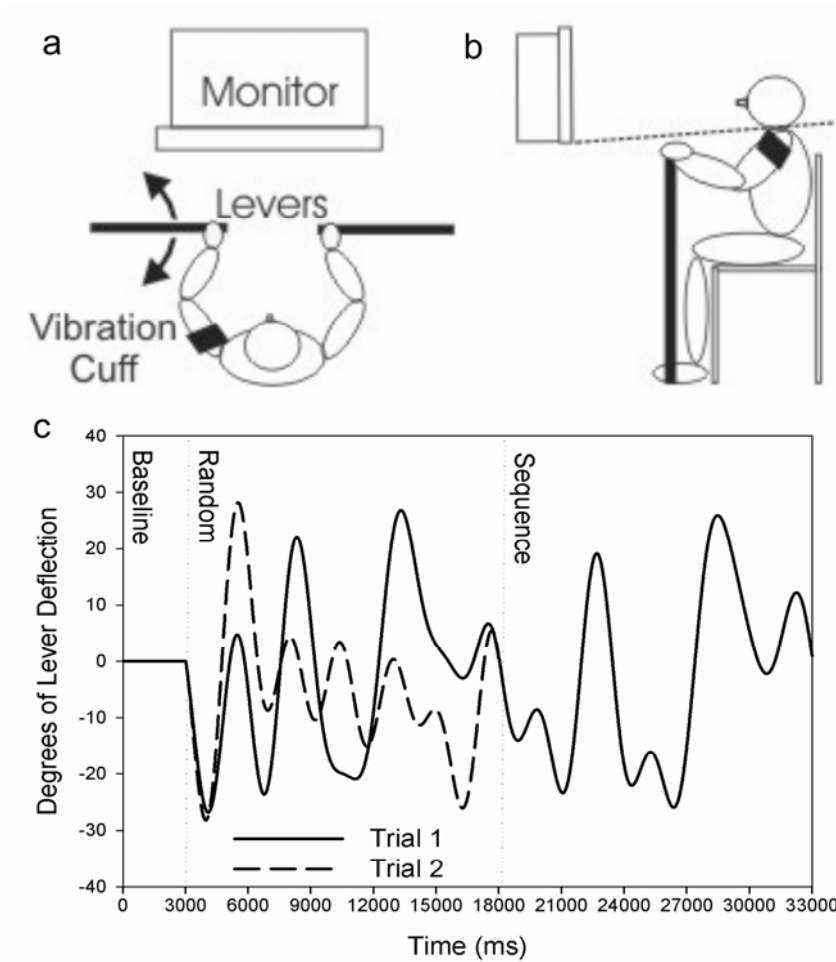

a) Participants were seated before a computer monitor and grip one (experiment 2) or both (experiment 1) horizontally mounted levers. A vibrating cuff was secured to one arm. Draping was drawn over the shoulders to prevent visualization of arm movement, represented by a dashed line in pane b. c) In experiment 2, participants followed a pattern of movement similar to these two example trials. Following a 3s stable baseline, sine-cosine waveforms dictated target movement. Two full trial waveform patterns, 1 random and 1 repeating sequence each, are overlaid. The random epoch comes first, followed by the repeated sequence epoch during both trials for ease of visualization.

Figure 2.2 Effect of Vibration on Limb Excursion Sense.

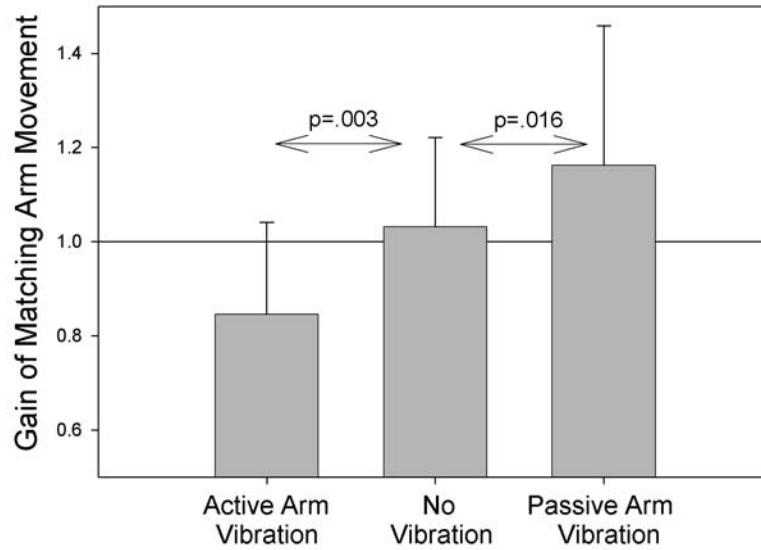

During the limb position matching task, participants interpreted the vibrated arm as having moved to a greater extent than in reality. This resulted in significantly reduced (AV) or increased (PV) gain measures when vibration was applied compared to when vibration was not applied.

Figure 2.3 Tracking Performance Examples.

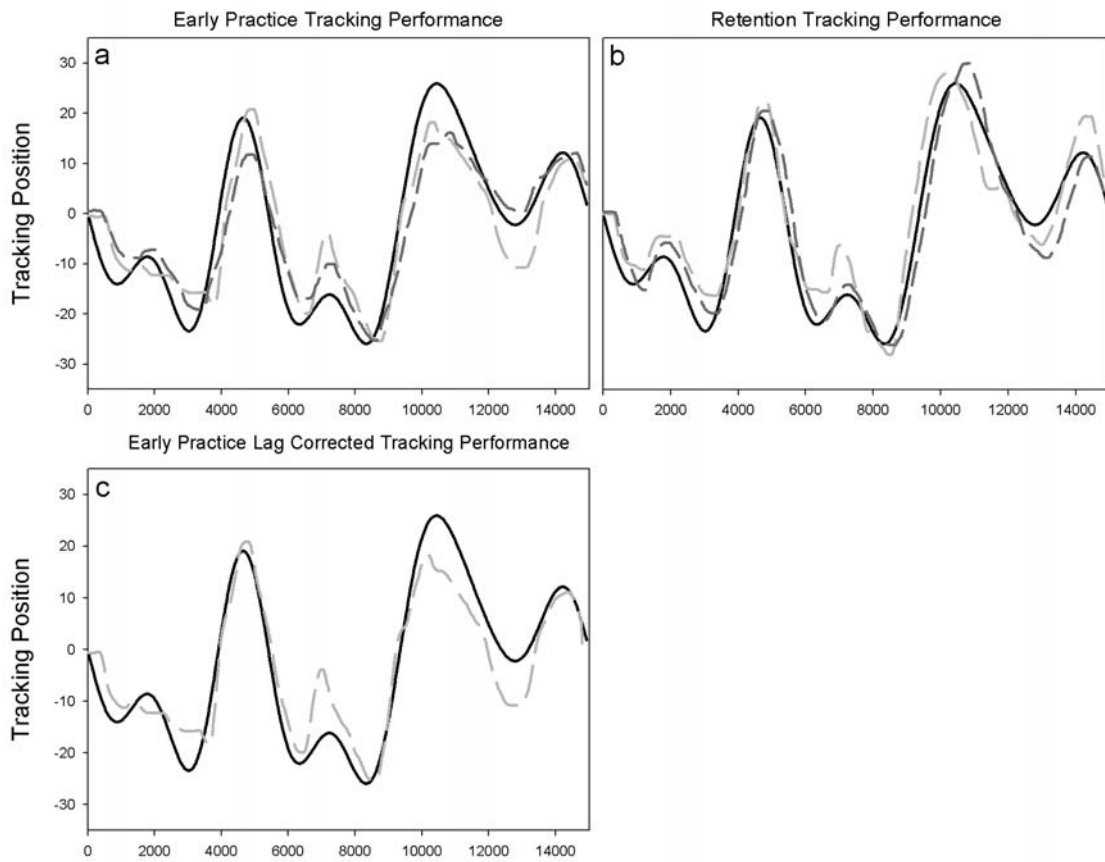

Performance on the repeated epoch of one participant in the CTL group (dashed, light gray) and one in the DIS group (dashed, dark gray). Early block 3 (a) and retention (b) tracking performance is plotted against the target pattern (solid black). In addition, the early tracking performance of the example CTL participant can be seen in pane a, corrected for a lag of 240ms (c).

Figure 2.4 Tracking Error.

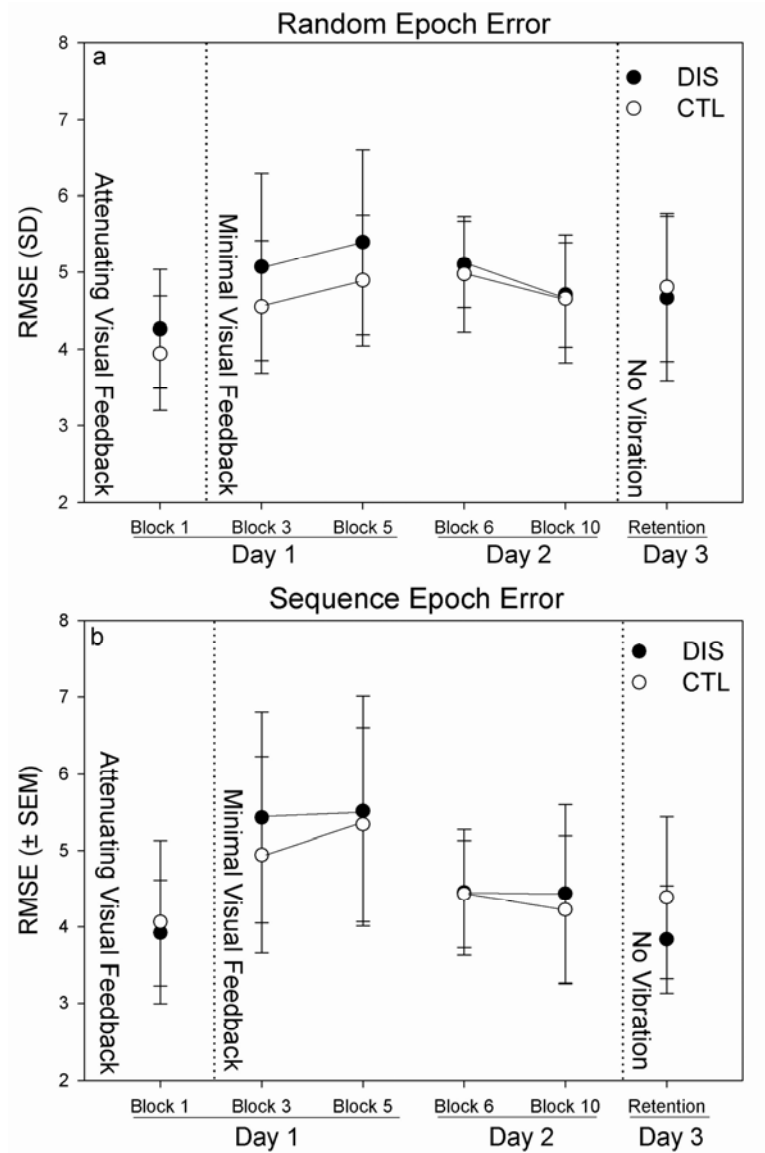

Average RMSE over tracking practice (days 1 and 2) and retention (day 3). Decreased RMSE, towards graph bottom, denotes improved motor performance. Block 1 represents initial performance with attenuating visual feedback but also vibration. Blocks 3,5,6 and 10, with vibration and minimal visual feedback, show an interaction of epoch and block suggesting improvement on sequence epoch tracking over time. At retention, when vibration was removed but minimal visual feedback maintained, improvements on sequence epoch

tracking persist regardless of group, providing evidence that altered proprioception disrupted performance but did not impair continuous sequence learning. Dotted lines represent changes in visual input or vibration.

Figure 2.5 Spatial Tracking Error.

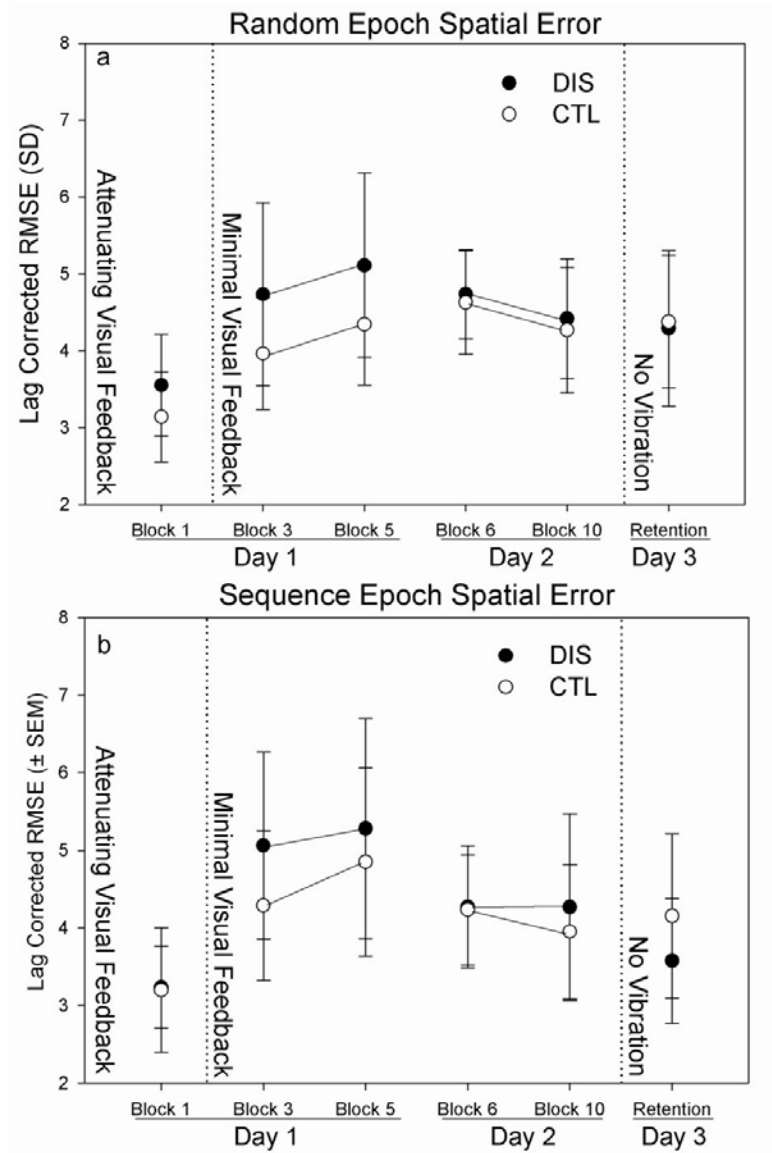

Average RMSE corrected to remove temporal lag over tracking practice (days 1 and 2) and retention (day 3). These error scores reflect spatial accuracy. Group x Block and Epoch x Block interactions suggest that vibration affected spatial tracking accuracy during practice. By retention testing, these group differences were eliminated, leaving only epochrelated performance differences. Decreased RMSE, towards graph bottom, denotes improved motor performance.

Figure 2.6 Temporal Tracking Error.

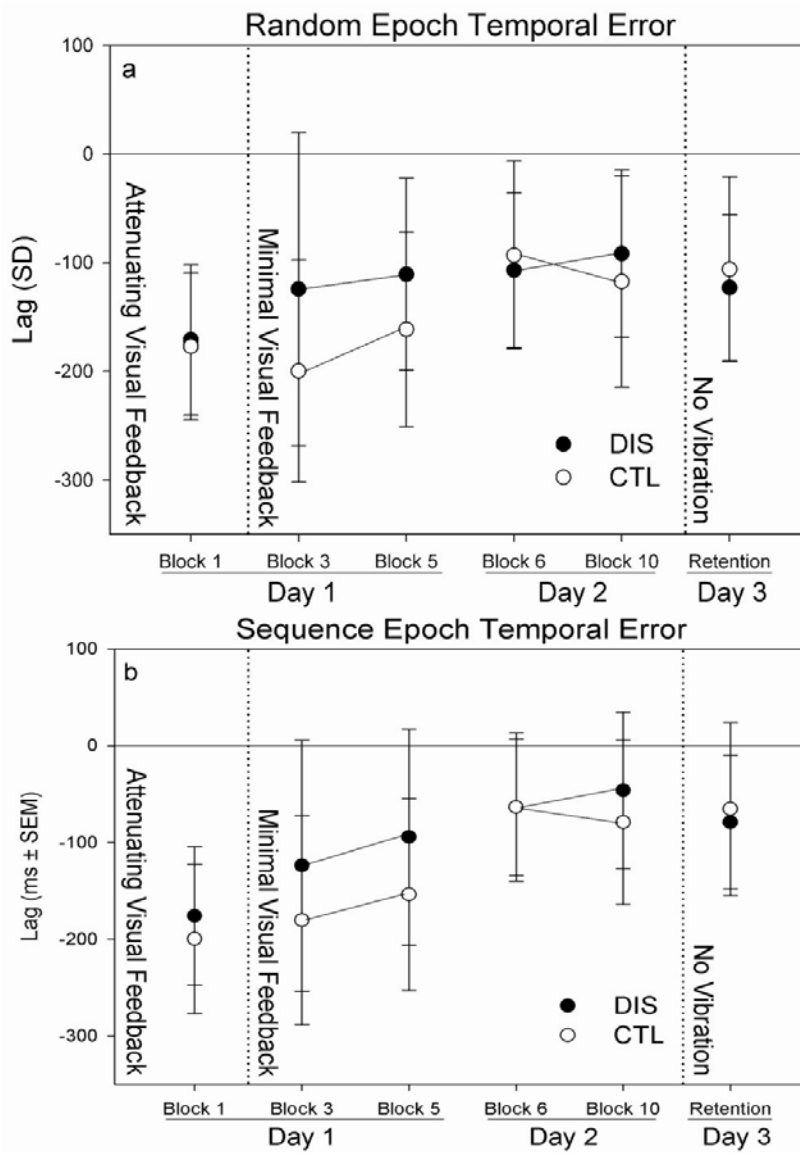

Average tracking lag in milliseconds over skill practice (days 1 and 2) and retention (day 3). These values reflect temporal accuracy. The horizontal line represents zero tracking lag. A Epoch x Block interaction during practice suggests that both groups improved temporal accuracy over time in an epoch respective manner. This effect persisted into retention testing. Increasing lag values, towards the zero line, denote performance improvements.

### **Chapter 3 Preface**

During the development and proposal of this dissertation, the role and character of vision during learning of a continuous tracking task was questioned. Specifically, it was wondered if eye movements would lead arm movements during the course of skill acquisition or if learned eye motions could be a strategy to compensate for proprioceptive disruption. Experimentally, these concerns were controlled in the paper presented in Chapter 2 by severely restricting visual feedback. However, the question led to the genesis of an additional experiment presented here in Chapter 3.

Nine healthy young adults performed the continuous tracking task described previously with a computer mouse. No proprioceptive disruption was performed. Eye movements were recorded during all trials. Continuous visual feedback of the mouse position was provided. Therefore participants were able to constantly calculate tracking error with vision. This enabled a dissociation of the contributions of the eye versus arm during the learning of the continuous tracking task.

## **Chapter 3**

### **Manual and Oculomotor Performance Develop Contemporaneously But Independently During Continuous Tracking**

Vidoni, E. D., McCarley, J. S., Boyd, L. A. Manual and Oculomotor Performance Develop Contemporaneously But Independently During Continuous Tracking. (to be resubmitted to *Human Movement Science*, 2008).

### *3.1 Abstract*

The coordination and unique contributions of the oculomotor and manual effector systems during continuous motor tracking tasks has not been well characterized. Over 2 days participants controlled a computer mouse with movements of their arm to follow an onscreen target while eye movements were recorded. Though improvements in both oculomotor and manual tracking accuracy were noted, differences between effectors were also apparent. Time series analysis and multiple linear regression were employed to probe spatial and temporal accuracy within each effector system. Oculomotor tracking accuracy primarily depended on spatial accuracy. In contrast, manual tracking performance was equally associated with both decreased time lag and more accurate spatial tracking. These findings indicate that oculomotor and manual tracking accuracy improved contemporaneously, though they contribute differently to improve accuracy during continuous motor sequence acquisition.

### *3.2 Introduction*

Skilled behaviors often require close coordination between manual and oculomotor movements. Imagine reaching for your coffee mug without first observing its location. Though arm movements can be made to a remembered position, foveation of the target improves accuracy.(Bock and Eckmiller 1986) Past work studying the relationship between vision and manual motor systems during goal-oriented discrete reaching movements has been extensively studied.(Carlton 1981; Desmurget et al. 1998; Keele and Posner ; Vaziri et al. 2006) These data indicate that individuals tend to make a saccade to the target in advance of limb motion (Helsen et al. 2004); that is for discrete end-point movements, motion of the eyes leads the limb to ensure accurate end position.(Helsen et al. 2000; Helsen et al. 2004) The conclusion that the eyes lead the arm during discrete predictable movements is further supported by documentation of anticipatory saccadic behavior during serial movements where each successive manual movement is known in advance and can be pre-planned. (Marcus et al. 2006)

Research has demonstrated that expectation (Kowler and Steinman 1979b) and learning (Marcus et al. 2006) can influence eye motor control. For example, anticipatory smooth eye movements occur in response to learned target movement regularities.(Kowler and Steinman 1981; 1979a; 1979b) In fact, the expectation that prior target movements will predict future appearances appears to strongly influence future smooth eye movements.(Kowler et al. 1984) It has also been demonstrated that individuals are able to produce anticipatory smooth pursuit movements and improve error during oculomotor pursuit of repeated target patterns.(Barnes and Schmid 2002; Burke and Barnes 2007; McHugh and Bahill 1985)

The ocular and limb (i.e. arm) motor control systems have been noted to be so well associated that it has been suggested that they have access to a common efference command (Steinbach and Held 1968) or internal model.(Vercher et al. 2003) Work to verify the theory that eye and limb movement are planned simultaneously, though, has been limited to the study of discrete end-point movements and self-moved target tracking. Little work has considered the development of oculomotor and manual tracking proficiency during learning of continuous sequences of motion. Ketcham and colleagues (2006) examined the interaction of eye fixations and arm movements during cyclic shape drawing but allowed participants to practice in advance of recording and to use relatively familiar shapes. The present study was designed to determine how ocular control is shifted by practice of continuous motor sequences.

Motor learning of continuous sequences has been well described for the arm (Pew 1974; Shea et al. 2006; Wulf and Schmidt 1997) and whole body.(Shea et al. 2001) However, the relative contribution of learned eye movements to the performance of predictable, repeated continuous sequences of motion has not been evaluated. Thus the purpose of this study was to parse the relative contributions of changes in eye movements versus arm motor control during the learning of a novel, repeated continuous sequence. Based on past work, we expected that the eyes might lead the arm in the learning of continuous sequences as evidenced by an interaction of practice and effector. Further, we hypothesized that oculomotor and manual error scores would display a moderate relationship with multiple regression analysis.

We employed a modified version of a well-characterized continuous tracking task (Pew 1974; Wulf and Schmidt 1997) to assess learning of an embedded repeated pattern. Over two practice days, participants engaged in 10 blocks of 10 tracking trials. We were able

to separate learning from short-term performance effects by having individuals return for one block of trials on a third, retention testing day. (Salmoni et al. 1984) Both manual and oculomotor tracking behavior was recorded simultaneously. Root mean squared tracking error (RMSE<sup>4</sup>) was separated into spatial and temporal components using a time series analysis. We also employed multiple regression analysis to examine the relative contributions of spatial and temporal tracking to overall performance for both the eye and arm effectors.

### *3.3 Methods*

#### *Participants*

Nine right-handed adults (mean age 21.7± 3.7; 5 males) with no reported neurological or orthopedic pathology provided institutionally approved informed consent. Participants were screened for normal or corrected visual acuity (all 20/20) and colorblindness.

#### *Procedure*

Seated participants rested their heads in a chin rest 57cm in front of a 55.8cm computer monitor (1024 x 768 resolution, 60Hz refresh rate). One centimeter onscreen subtended 1 degree of visual angle. An Eyelink II eyetracker (SR Research Ltd., Mississauga, Ontario, Canada) with temporal resolution of 250Hz and spatial resolution of better than 0.01° recorded eye movements. Position of the participant's gaze and a mouse-controlled cursor were recorded every 17ms for subsequent processing.

---

<sup>4</sup> RMSE = SQRT( $\sum(x_i - X_i)^2/n$ ) where  $x_i$  = manually controlled cursor position,  $X_i$  = target position

Each participant performed two sessions of training, with each session comprising 50 trials 30s in duration (5, 10 trial blocks per day). They were instructed to follow a target as accurately as possible by moving a computer mouse. The mouse was placed in a track that permitted movement only in a parasagittal plane. Each trial began when the subject gazed at a central fixation cross and pressed the space bar. Immediately following, a 0.87cm x 0.87cm target box and a circle of 0.38cm diameter corresponding to mouse position appeared at the screen's center. After a 2s delay, the target began to move vertically in a semi-sinusoidal pattern. Participants attempted to follow the target with the position cursor as accurately as possible. Maximum vertical deviation of the target was limited to 24.7cm. Target movement patterns were dictated according to a method modified from Wulf and Schmidt (1997) as reported previously.(Boyd et al. in press) Briefly, two sine functions were joined in random order; one 11s novel pattern and one 11s repeated pattern. The repeated pattern or epoch was the continuous movement sequence to be learned by the participant. The same repeated pattern was used every trial.

All participants returned on a separate, third day for retention testing. Separate retention and training sessions are necessary to adequately dissociate learning-related changes in behavior from transient performance improvements.(Salmoni et al. 1984) Retention testing included ten continuous tracking trials in the same manner as practiced.

#### *Outcome measures*

Saccades, gaze and manual position were reported by the Eyelink software. Smooth pursuit durations and saccade counts were determined then gaze and manual position data were smoothed using a 100ms moving average. Our primary outcome measure was average RMSE on the repeated pattern for each block of ten trials. Additionally, we performed a time-

series analysis on these data to parse spatial and temporal changes in behavior (Boyd and Winstein 2004a; Day and Marsden 1982). Manual position data from each trial epoch was serially correlated with the target position. The position data were “slid” along the target data to a maximum of 500ms of lead and lag. Only continuously overlapping sections of target and position data were correlated to avoid sample size biasing from different temporal shifts across trials and participants. The position of highest correlation was taken as the temporal lead or lag as compared to target movement. The distance the position data were slid were converted to ms to demonstrate the temporal accuracy of tracking. RMSE was recalculated after the timing error had been accounted for as a measure of pure spatial error. Real time correlation coefficients that did not exceed  $r=0.5$  were flagged and these trials were withdrawn from all analyses (< 5% for all participants).

### *Statistical Analyses*

To examine the effect of task training, all variables of interest were subjected to two-way ANOVA [Effector(arm, eye) x Block (1, 5, 6, 10, Retention)] with repeated measures correction for both factors. Only the first and last blocks of the practice days were included to provide an overall picture of practice related improvement. ANOVA analyses were tested at  $\alpha = 0.01$  and Greenhouse-Geisser correction was employed. To assess learning for each effector, predefined pairwise t-testing was performed on the first block of practice and retention. These post hoc analyses were tested at  $\alpha = 0.05$ . Additionally, to examine the contributions of temporal and spatial performance by each effector to overall performance, stepwise multiple linear regression modeling was performed. The spatial RMSE and temporal lag of both effectors were used as the predictor variables. Real time gaze and manual RMSE

were treated as independent outcome variables. Adjusted coefficients of determination for the most predictive model regardless of parsimony are reported. However, change in  $R^2$  values are provided for purposes of interpretation. Criterion for entry was a  $p < 0.05$  and variables were checked for multicollinearity ( $VIF > 10$ ).

### *3.4 Results*

Overall, improvements were noted across practice for both manual and oculomotor tracking. Disparate effects of effector (eye and arm) and practice (practice block) were found for spatial and temporal learning. The spatial and temporal components of accuracy were differentially related to performance between effectors. Two-way ANOVA [Effector (arm, eye) x Block (1, 5, 6, 10, Retention)] with repeated measures correction of both factors was performed on variables of interest. Only sequence epoch performance was considered for these analyses.

#### *Real-time Tracking Error*

The primary measure of manual continuous tracking performance was RMSE. Reduced RMSE over time indicates improvement in tracking accuracy associated with practice. Participants became more accurate with practice as indicated by a main effect of Block ( $F_{2,34}=5.372$ ,  $p=0.001$ , Figure 3.1). Additionally, manual tracking was more accurate than oculomotor tracking ( $F_{1,16}=9.475$ ,  $p=0.007$ ). Retention of the learned behavior was confirmed by significantly lower RMSE scores at retention when compared to the first block of practice for both manual ( $p=0.007$ , large Effect Size (ES) = 1.05)(Thomas et al. 1991) and oculomotor ( $p=0.045$ , large ES=1.26) continuous tracking. Effect sizes for these significant

improvements in error indicate meaningful ( $ES > 0.8$ ) differences developed from initial performance over the course of practice (Cohen et al. 2003; Thomas et al. 1991).

To examine the relationship of oculomotor and manual RMSE, we correlated effector error scores on a trial-wise basis for Blocks 1, 5, 6, 10, and Retention. Manual and oculomotor deviations from the target were not closely associated as revealed by a weak relationship between effector error rates ( $r^2 = 0.093$ ,  $p < 0.001$ , Figure 3.2).

### *Spatial Tracking Error*

Spatial tracking accuracy did not improve over the course of practice for either the manual or oculomotor systems ( $F < 1$ , Figure 3.3). However, a main effect of Effector confirmed the difference in spatial error between gaze and manual tracking ( $F_{1,16} = 22.542$ ,  $p < 0.001$ ).

### *Temporal Tracking Error*

An improvement in tracking lag for both effectors with practice was noted. Reduced lag over time indicates a learned ability to predict upcoming target location and hence to be closer to it in time. Participants made improvements over practice as indicated by a main effect of Block ( $F_{3,58} = 8.769$ ,  $p < 0.001$ , Figure 3.4). Post-hoc testing revealed that both oculomotor ( $p = 0.001$ , large  $ES = 1.46$ ) and manual ( $p = 0.007$ , large  $ES = 1.159$ ) tracking lag improved by retention testing. No significant difference between effectors was noted.

### *Regression Analysis*

Multiple linear regression modeling was performed to examine which skill components were most predictive of real-time oculomotor and manual tracking

performance. In this manner we investigated the relationship of temporal and spatial task performance for both effectors to the tracking accuracy of one effector. Complete results are presented in Table 1.

Real-time oculomotor accuracy was almost exclusively predicted by spatial error of gaze ( $R^2 = 0.970$ ,  $p < .001$ ). Temporal accuracy made only a minor improvement to the model ( $R^2$  change = 0.019,  $p < .001$ ). Interestingly, manual spatial error made a significant but essentially nominal contribution to the model (Figure 3.5a).

A somewhat different model was formulated for manual tracking performance. The most predictive element of manual tracking performance was manual temporal accuracy ( $R^2 = 0.599$ ,  $p < .001$ ). Adding manual spatial accuracy improved the model markedly ( $R^2$  change = 0.347,  $p < 0.001$ ). As noted with gaze accuracy, spatial error of the other effector made a nominal but significant contribution to the predictive model of manual tracking performance, ( $R^2$  change = 0.001,  $p = 0.045$ , Figure 3.5b).

### *3.5 Discussion*

The purpose of this study was to characterize the relationship between oculomotor and manual tracking during continuous motor sequence learning. Past work has shown that both manual and visual systems can exhibit learning-related improvements in performance of target tracking. (Barnes and Schmid 2002; Pew 1974) However, few studies have examined concomitant changes in manual and oculomotor effector systems during continuous motor sequence learning. Our use of a continuous motor sequence paradigm allowed the examination of visual and manual movement relationships during continuous tracking with a high requirement for precision. In addition, our use of a retention test design allowed the

separation of short-term change in behavior that is associated with performance from long-term learning.

Smooth pursuit is generally considered to be dependent on the stimulus and not the observers intentions in most situations.(Murphy et al. 1975 1975; Steinman et al. 1973) However, there is some evidence to suggest that smooth pursuit tracking can improve with repeated exposure to regularities in the environment.(Bahill and McDonald 1983; Barnes and Schmid 2002; Kowler and Steinman 1979a) Furthermore, when participants manually control the object on which they gaze, smooth pursuit becomes anticipatory suggesting a common source of motor commands.(Lazzari et al. 1997; Steinbach and Held 1968) This common access to motor commands (efference copy) is purported to account for coordinated behavior between effectors.(Lazzari et al. 1997; Vercher et al. 1997)

Based on previous reports we expected to detect a relationship between oculomotor and manual performance. In agreement with that work, both manual and oculomotor systems exhibited contemporaneous block-wise improvements in tracking accuracy in the present study. However, relative independence in trial-wise error was also observed. Furthermore, spatial accuracy and temporal lag for each effector were minimally predictive of overall error for the other effector. Were the two systems more integrated during continuous tracking, a stronger relationship between the two would be expected. For example, if spatial oculomotor error resulted in poor manual tracking as a function of failure to consistently foveate on the target, a predictive relationship might exist between spatial oculomotor error and manual real-time error. Instead we found essentially no predictive relationship between the two effectors. One explanation for the difference between past work that showed a strong relationship between the arm and eye during tracking and our data may be the length of the practiced sequence of movements. In the present research, we employed a much longer continuous

tracking sequence (11s) than has been previously reported. Other work considering continuous tracking used a 15s non-continuous sequence of four smooth pursuit movements (Burke and Barnes 2007) and a 4-step stimulus lasting no longer than 3s.(Barnes and Schmid 2002)

Previous studies have reported the relative dominance of the visual system for more accurate movements during discrete reaching tasks.(Hirata and Yoshida 2000; Lateiner and Sainburg 2003) We found little evidence of a close relationship between oculomotor and manual error during continuous tracking: i.e., manual accuracy did not depend on visual tracking accuracy. However, we are not the first to report a degree of independence between the visual and manual systems. Dissociation of vision and manual movement planning has been demonstrated during discrete reaching under conditions of prism adaptation,(Hatada et al. 2006) limited visual feedback (Mackrout and Proteau 2007) and to remembered targets.(Ren et al. 2006) Our study confirms and extends these reports to include continuous sequence-learning. The data indicate that though each effector system may have access to the same information regarding upcoming movements, they are able to operate separately from one another and are not inextricably linked. This level of independence may be an important feature that facilitates both flexibility in responding and overall motor learning as each effector system may capitalize on the information it finds most salient to improve motor performance.

It is possible that rather than be constrained by a high degree of association between eye and hand, tracking benefits more from an independent visual system that can search for and exploit environmental or stimulus regularities. Marcus and colleagues (2006) posited that the visual system may scout ahead and anticipate upcoming actions in an effort to improve manual responses even in the absence of stimulus regularities. Anticipatory eye movements

occur during serial reaction time tracking for upcoming stimuli regardless of whether a repeating and predictable or random and surprising sequence is present. The eye movements may be scouts, assisting manual response with as much advance information as is possible. This could explain the overall increased error score of eye tracking that was observed in the present study; as the eye works to guess where the continuous sequence will move next, more error, but also more information available to guide learning, is generated by incorrect eye motion. Alternately, the present finding of greater oculomotor error could be explained by the paradigm itself. Participants were only instructed to maintain the cursor position as close to the target as possible. No instructions were given regarding visual tracking.

This study presents an important extension of previous investigations into oculomotor and manual coordination. We recorded both oculomotor and manual movements during acquisition of a novel movement pattern with which participants had no prior experience. Learning was differentiated from performance by assessing tracking accuracy on a separate retention day following 2 days of skill practice. This differs from prior studies of oculomotor sequence performance conducted in 1 session.(Barnes and Schmid 2002; Burke and Barnes 2007; Marcus et al. 2006) Findings of the present study may represent a more ecologically valid representation of visual and manual coordination during skill learning wherein the two systems learn and interact to produce a motor pattern but are not codependent.

**Chapter 3 Tables and Figures**

Outcome Variable	Predictor Variables	R	Adjusted R <sup>2</sup>	R <sup>2</sup> change	Model Significance
Real-time Oculomotor RMSE	Oculomotor Spatial Accuracy	0.985	0.970	--	Model: F <sub>1,358</sub> =11675.119 p<0.001
	Oculomotor Spatial Accuracy & Oculomotor Temporal Accuracy	0.995	0.989	0.019	Model: F <sub>2,357</sub> =16394.173 p<0.001 R <sup>2</sup> change: F <sub>2,357</sub> =629.108 p<0.001
	Oculomotor Spatial Accuracy & Oculomotor Temporal Accuracy & Manual Temporal Accuracy	0.995	0.989	0.000	Model: F <sub>2,357</sub> =11066.406, p<0.001 R <sup>2</sup> change: F <sub>1,358</sub> =5.415 p<0.021
	Manual Temporal Accuracy	0.775	0.599	--	Model: F <sub>1,358</sub> =537.341 p<0.001
	Manual Temporal Accuracy & Manual Spatial Accuracy	0.973	0.946	0.347	Model: F <sub>2,357</sub> =3154.621 p<0.001 R <sup>2</sup> change: F <sub>1,357</sub> =2308.482 p<0.001
Real-time Manual RMSE	Manual Temporal Accuracy & Manual Spatial Accuracy	0.973	0.947	0.001	F <sub>3,356</sub> =2122.443 p<0.001 R <sup>2</sup> change: F <sub>1,356</sub> =4.057 p=0.045
	Manual Spatial Accuracy				
	Oculomotor Spatial Accuracy				

Table 3.1 Regression Statistics

Summary of regression model statistics for prediction of real-time tracking error based on manual and oculomotor component spatial and temporal error.

Figure 3.1 Real-time Tracking Error

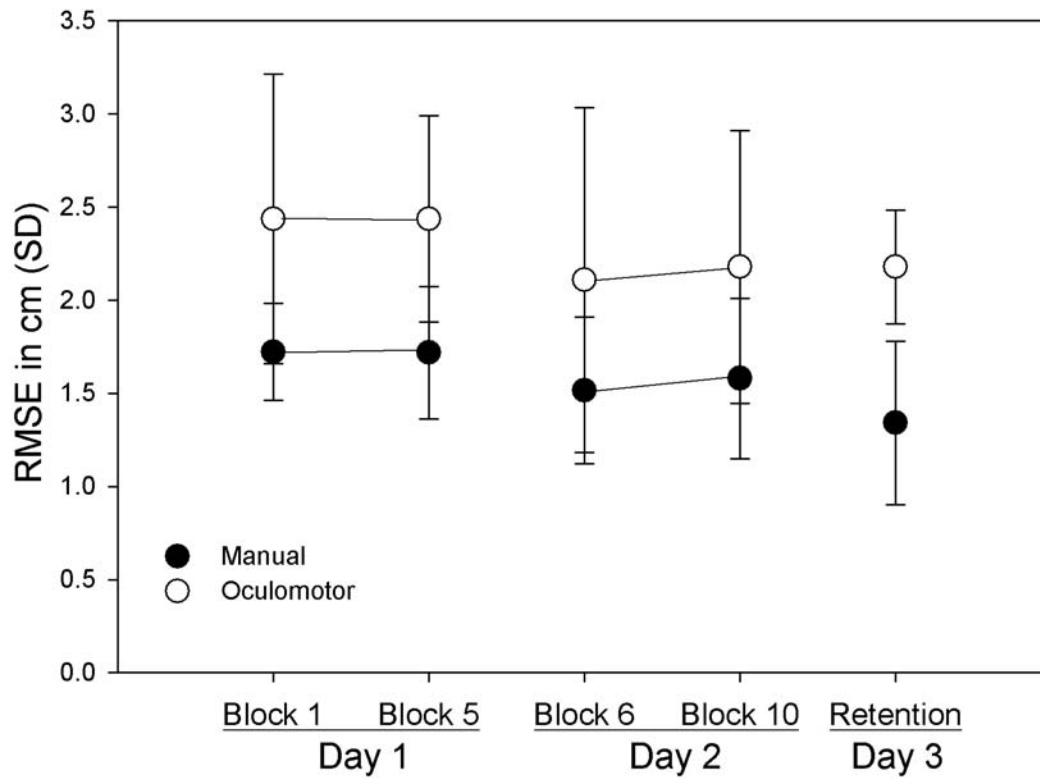

Real-time tracking RMSE (centimeters and standard deviation, SD) for both effectors over the course of practice and at retention. Main effects of Block and Effector confirm retained improvement over practice and greater manual accuracy.

Figure 3.2 Trialwise Manual and Oculomotor Tracking Error

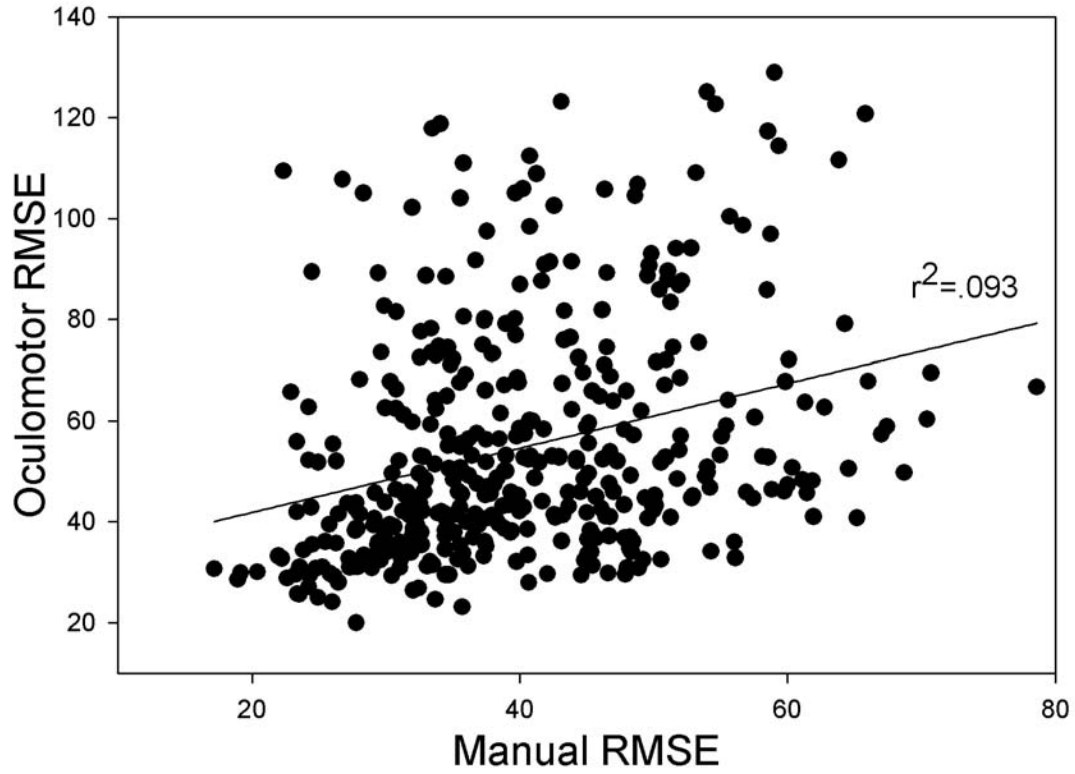

For each trial (Blocks 1, 5, 6, 10 and Retention, across all participants), oculomotor tracking is plotted against manual tracking error. The coefficient of determination suggests a weak relationship between the two effector systems during performance.

Figure 3.3 Spatial Tracking Error

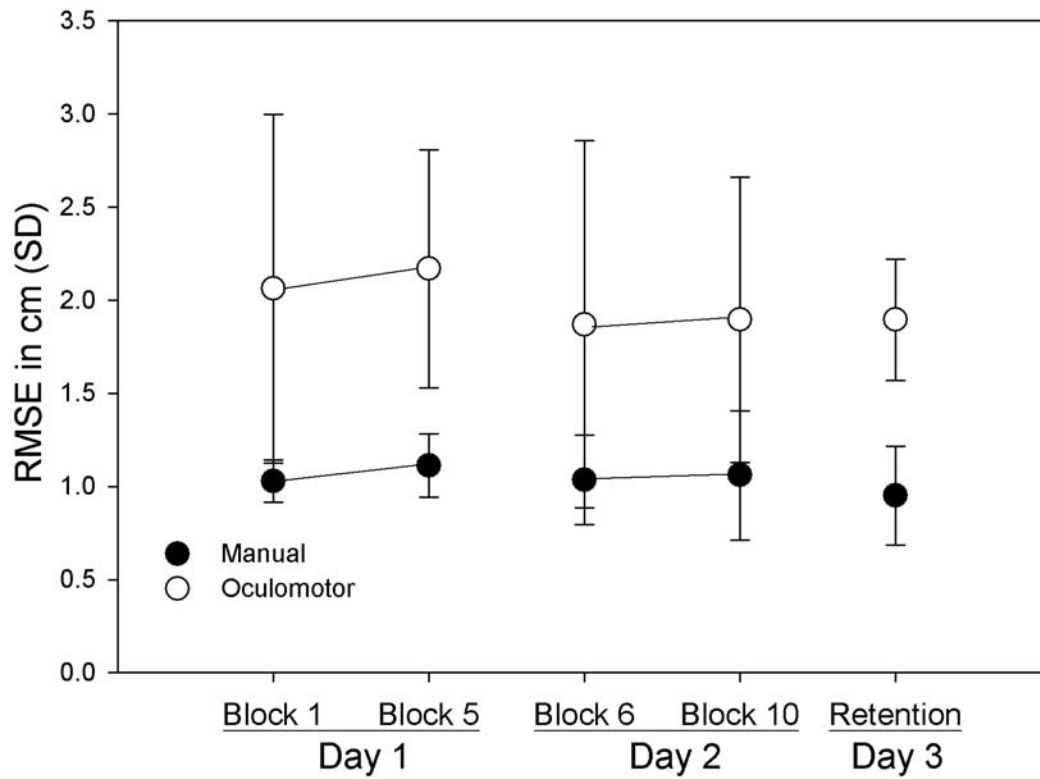

Spatial Tracking RMSE for both effectors over the course of practice and at retention. RMSE is reported in centimeters (standard deviation, SD). The first and last block of each of the two practice days are shown as well as the only performance block on the retention day. Spatial error between the manual and oculomotor systems was significantly different. However, no effect of practice was found.

Figure 3.4 Temporal Tracking Error

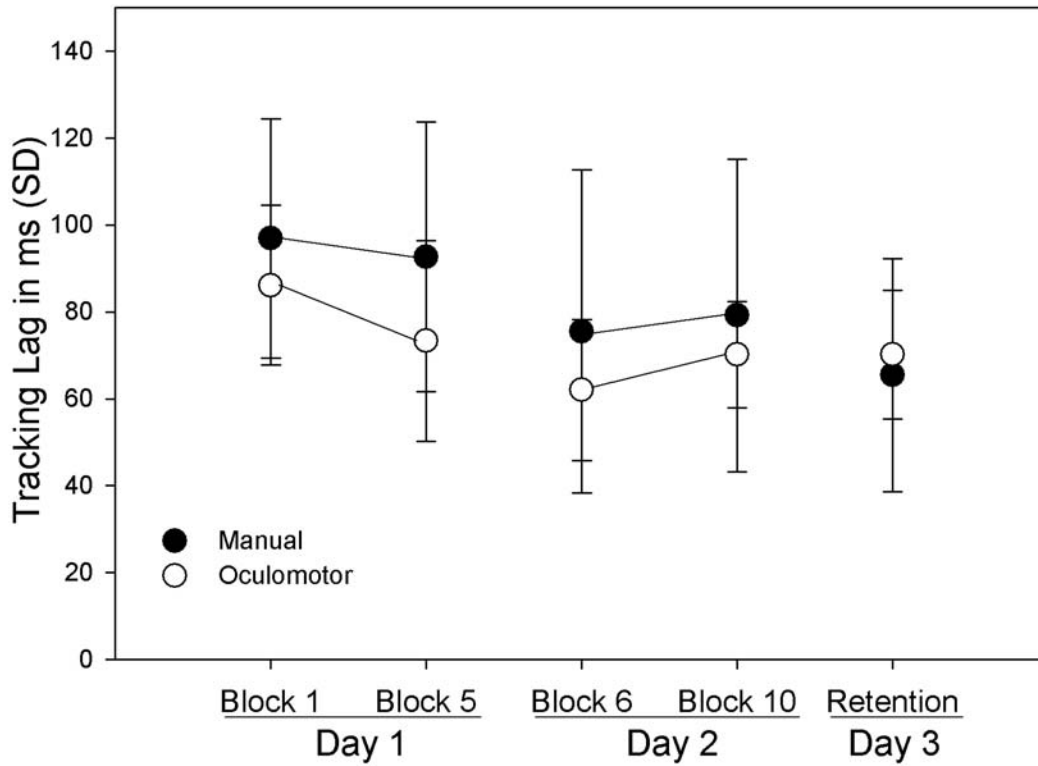

Temporal tracking error for both effectors over the course of practice and at retention. Gaze and manual lag behind the target is reported in milliseconds (standard deviation,SD). The first and last practice block of each of the two practice days are shown as well as the only performance block on the retention day. Lag significantly improved over time regardless of effector.

Figure 3.5 Goodness of Fit for Tracking Error Regression Models

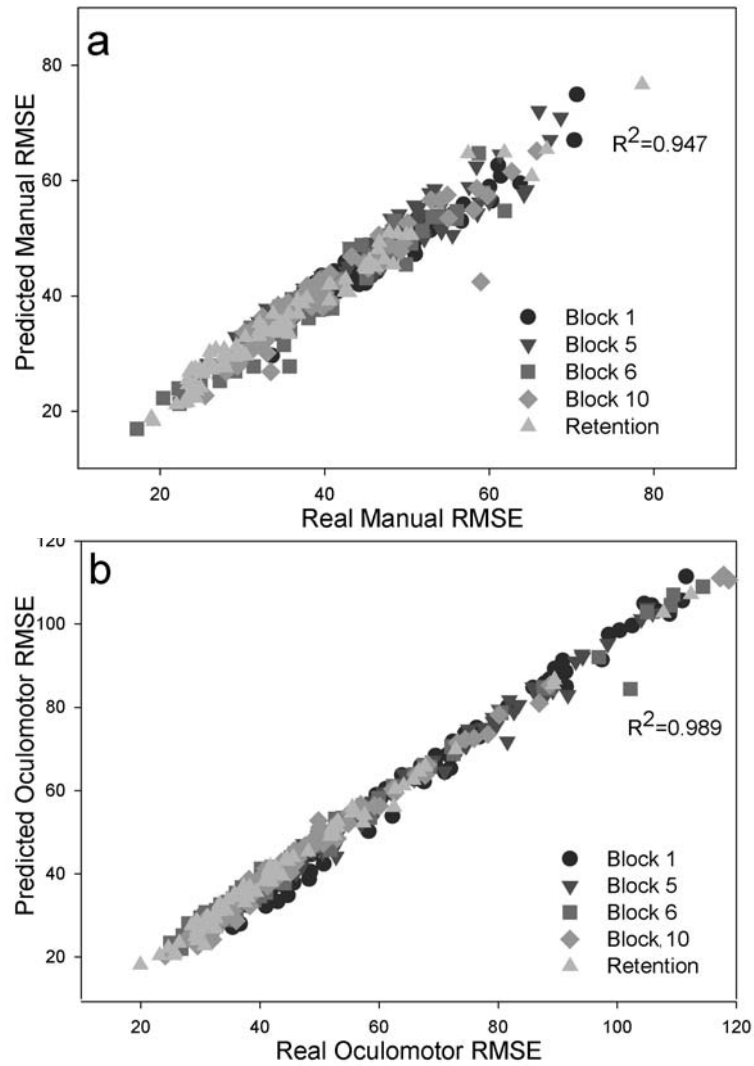

Goodness of fit scatter plots of real versus predicted RMSE based on regression modeling. Each trial in practice blocks 1, 5, 6, 10 and during retention is plotted for each participant. Blocks are separated by shape. Panel (a) displays manual tracking performance. Panel (b) displays oculomotor tracking performance.

## **Chapter 4 Preface**

In the previous chapters healthy young adult participants engaged in a motor learning task, some under conditions of peripherally disrupted proprioception. Regardless of proprioceptive disturbance individuals were able to demonstrate sequence-specific motor sequence learning over time suggesting that other sources of feedback were used to learn the task.

The findings in Chapter 2 were contrary to the hypothesis that disrupted proprioception would diminish sequence learning. This may be a function of central versus peripheral disruption. A review of the literature hints at this possibility. Previous work has demonstrated that peripherally deafferented monkeys retain the ability to learn tasks (Taub et al. 1966; Taub et al. 1978), but that lesions of the central sensory processing areas diminish learning capacity.(Pavlides et al. 1993; Sakamoto et al. 1989) In the following chapter individuals with stroke and healthy control participants trained on the same tracking task used in Chapter 2, though owing to their already centrally disrupted sensory systems, no disruptive vibration was applied during motor skill practice. In addition, the sensory integrity and lesion location of the individuals with stroke were assessed to provide a picture of central proprioceptive perceptual health. This study is a human correlate to the non-human primate work on learning after lesioned sensory cortex.(Pavlides et al. 1993; Sakamoto et al. 1989)

## **Chapter 4**

### **Stroke-related Proprioceptive Deficit is Associated With Disrupted Motor Learning**

Vidoni, E.D. & Boyd, L.A. Stroke-related Proprioceptive Deficit is Associated With Disrupted Motor Learning. (submitted to *Experimental Brain Research*, Dec. 2007)

#### *4.1 Abstract*

Most motor learning theories posit that proprioceptive sensation serves an important role for acquiring and skillfully performing a novel movement pattern. Investigations in animal models of brain lesions strongly support this belief. However, research with deafferented individuals or experimental paradigms that exogenously disrupt proprioception via vibration reveal mixed results. Further, little work has considered individuals with sensory pathology affecting central proprioceptive pathways which would more directly correlate to the animal lesion models. Though the literature is replete with general studies of human motor learning, there is a paucity of work specifically addressing the interaction between proprioception and motor sequence learning. To address this gap in the research, 10 middle cerebral artery (MCA) stroke survivors and 9 similarly aged healthy control participants performed a continuous tracking task with an embedded repeating section over two days and returned a third day for retention testing. A limb-position matching task was used to index proprioception. We report here that individuals with chronic stroke with involvement including the sensory regions of the cortex and associated white matter tracts are able to learn to track a pattern of continuous velocity changes; however, the magnitude of behavioral change associated with sequence specific learning was directly related to the integrity of central proprioceptive processing. These results are consistent with the animal models of central nervous system (CNS) damage to somatosensory areas and support of the concept that proprioceptive processing is necessary for motor sequence learning.

#### *4.2 Introduction*

It is commonly held that sensory feedback plays an important role in motor skill learning.(Schmidt and Lee 1999b) Animal evidence suggests that intact sensoricortical brain function is necessary for learning new skills including movement sequences. In cats (Sakamoto et al. 1989) and non-human primates,(Pavrides et al. 1993) lesions to sensory cortex do not impact gross motor skill production but inhibit motor learning. Asanuma and Pavlides (1997) proposed that motor learning occurs through paired and repeated stimulation of motor neurons by corticocortical and thalamocortical inputs such as might be present during practice; implicating the sensory cortex as an important “teacher” for the motor cortex during novel skill acquisition. Somatosensory cortex potentiation of motor cortical neurons in association with motor learning has been demonstrated previously in cats.(Iriki et al. 1989) Likewise facilitation of the motor cortex by sensory cortical activation in humans has also been reported.(Hamdy et al. 1998)

Perhaps the most common method of investigating sensorimotor interaction is via the study of peripheral disruption. Temporary exogenous sources of proprioceptive disruption, such as vibration,(Pipereit et al. 2006; Verschueren et al. 1999) and ischemic nerve block (Christensen et al. 2007) have been used to study motor control and adaptation in otherwise healthy individuals. In addition several studies have examined motor performance and adaptation in individuals with large fiber neuropathy resulting in absent proprioception. (Boussaoud et al. 1995; Cole and Sedgwick 1992; Ghez et al. 1995; Ghez et al. 1990; Gordon et al. 1995; Rothwell et al. 1982; Vercher et al. 1997) Taken together these studies have noted that the maintenance of internal representations of environmental forces and limb properties appear to be at least partly dependent on peripheral sources of proprioceptive input.(Ghez et al. 1990; Gordon et al. 1995) However, peripherally deafferented individuals

are likely to have well developed compensatory strategies (Cole and Sedgwick 1992; Rothwell et al. 1982) that rely on visual compensation.(Ghez et al. 1990) In contrast to findings that skill learning is negatively impacted by deafferentation,(Rothwell et al. 1982) maintenance of the ability to learn new movements has been reported after central lesions such as in dorsal rhizotomies in non-human primates.(Taub et al. 1966; Taub et al. 1978) Therefore it is not clear that the study of individuals with peripheral neuropathy or temporarily disrupted proprioception adequately addresses the role of central proprioceptive processing in motor skill learning.

Participation in motor learning studies by those with chronic non-progressive brain lesions such as stroke help to elucidate mechanisms of motor learning and inform us of the challenges faced by those with brain pathology. There is a developing body of literature regarding motor sequence learning following non-progressive brain injury. This work has implications for both motor learning theory and rehabilitation medicine. Whereas some studies have indicated individuals maintain the ability to learn sequenced movement patterns following stroke,(Boyd and Winstein 2003; Boyd and Winstein 2004b; Pohl et al. 2001; Vakil et al. 2000) stroke-related impairments of motor learning have also been reported.(Boyd and Winstein 2001) Boyd and Winstein (2001) noted impaired learning capacity in a group with primarily parietal and thalamic strokes; lesions that likely had and impact upon somatosensation including proprioception.

The present study was designed to address this gap in the literature regarding the importance of central proprioceptive processing for continuous motor sequence learning. Continuous sequencing tasks allow for the study of emergent procedural learning (Boyd and Winstein 2006; Spencer et al. 2003) and because of the need for constant position updating, are highly reliant on the proprioceptive system especially in the absence of visual feedback.

This is in contrast to other commonly employed motor learning paradigms. For example, proprioception may not be necessary for a series of discrete key presses where movements are largely planned in advance.(Nissen and Bullemer 1987) Continuous tracking also differs from studies requiring reaching to discrete targets in a novel environment,(Shadmehr and Mussa-Ivaldi 1994) where a commonly performed behavior is adapted to new dynamics. Finally, in the present study we considered the pattern of continuous velocity changes rather than absolute position (Boyd and Winstein 2006; Shea et al. 2001; Wulf and Schmidt 1997) as recent work has emphasized the encoding of velocity-based information by the proprioceptive system.(Hwang et al. 2006b; Prochazka and Gorassini 1998)

We hypothesized that if processing of proprioceptive feedback was necessary for motor learning, stroke-related damage to somatosensory cortical areas, thalamus and/or the white matter tracts associated with these regions would result in impaired continuous sequence learning. Furthermore, we expected that the magnitude of learning-related change in motor behavior would be related to the degree of proprioceptive impairment as measured by limb-position matching ability. We tested these hypotheses using a continuous tracking task in which we limited visual feedback. We additionally performed a separate retention test to dissociate learning from performance-related improvements.(Salmoni et al. 1984)

#### *4.3 Methods*

Twenty-one individuals with near vision corrected to at least 20/40, and with no history of diabetes or peripheral neurological damage were recruited from the greater Vancouver, B.C. and Kansas City, KS communities. Twelve individuals (CVA group) with a chronic stroke (at least 6mo post) primarily in the MCA distribution, and 9 age-matched ( $\pm 3$  yrs) neurologically intact individuals (HC group) provided institutionally approved

informed consent to participate in this study. Group characteristics are summarized in Table 4.1. Data from two CVA participants were excluded from analysis secondary to consistently poor tracking as defined in the outcome measures section of this manuscript (resulting CVA n = 10). The upper extremity portion of the Fugl-Meyer stroke recovery assessment (UEFM) provides a measure of motor function and was administered to all participants in the CVA group.(Fugl-Meyer et al. 1975) Individuals were compensated for travel expenses.

#### *Lesion Location*

Neuroanatomical scans were obtained for 7 of the 10 CVA participants. An MRI report was obtained for 2 of the remaining 3 individuals. T1 anatomical scans were converted to Talairach stereotaxic space using AFNI software.(Cox 1996) Lesions were traced using MRIcro software (C. Rorden, Columbia, SC). To illustrate the extent and location of lesions they were overlaid on a reference brain and are presented in Figure 4.1. Participant-specific lesion information is reported in Table 4.1.

#### *Motor Learning Task*

The task used in the present study was similar to that reported previously (Vidoni and Boyd 2007) and involved shoulder flexion and extension to move an on-screen cursor with a horizontally mounted lever restricted to movement in the transverse plane; elbow movement necessarily accompanied shoulder movement. Participants were seated in front of a computer monitor and engaged in a continuous tracking of a target moving in a sine-cosine waveform (Pew 1974; Wulf and Schmidt 1997) using either their dominant arm (HC) as determined by the Edinburgh Inventory (Oldfield 1971) or their hemiparetic arm (CVA). The target appeared as a white square and participant movements were represented as a yellow circle

cursor. Lever position sampling and all stimuli were presented at 40Hz using custom software developed on the LabView platform (v. 7.1; National Instruments, Austin, TX). To ensure that participants could achieve the necessary range of movement, prior to testing, all participants moved the lever to their maximum flexion and extension excursion. If maximum volitional movement was insufficient for task performance (as a result of tone or contracture), the software was calibrated such that the maximum excursion necessary to perform the task was ~2cm less than maximum possible excursion. This was necessary for only one participant with stroke. For all other participants, 31cm of angular excursion was required to accurately track the target. In addition, an elastic wrap was used to help keep the hand of two individuals with stroke on the lever.

The pattern of target movement was predefined according to a method modified from Wulf and Schmidt (1997). A unique 33s trial was constructed from one 3s baseline and two 15s sine-cosine waveforms, or “epochs.” During each trial, participants were exposed to one novel random epoch and one epoch that contained a repeated waveform (Figure 1.1c). The presentation of the repeated epoch, first or last in each trial, was randomized to minimize order effects. The same trial order was employed for every participant. Participants were not informed of the repetition but instructed only to track the target as accurately as possible by controlling the position cursor with the lever.

### *Experimental Design*

Individuals practiced the tracking task 50 trials a day for two days. On a separate third day, participants returned for 10 retention test trials. No practice or “warm-up” trials were allowed prior to testing on any day. To maximize dependence on proprioceptive information, visual feedback of movements was severely restricted. Draping was placed

over, but did not come in contact with, the participant's upper body to prevent vision of the arms. Additionally, over the first 20 practice trials, visual feedback intended to aid participants initial understanding of the task was faded out. (Vidoni and Boyd 2007; Winstein et al. 1994) To accomplish this, arm position (cursor) information was faded from continuous presentation on trial 1 (block 1), to a 200ms duration presentation every 2s by trial 19 (block 2). This frequency is *much lower* than which Kao (1976) reported to be virtually useless for guiding continuous hand-controlled cursor movements. To encourage and motivate individuals for this difficult task, summary feedback regarding overall tracking accuracy was provided after each trial as a percentage of time the position cursor spent within a 10° bandwidth of the target. This summary feedback did not contain sufficiently specific information to alter performance characteristics or reliably improve tracking on the repeated epoch.

### *Indexing of Proprioception*

As in Chapter 2, the ability to access and discriminate proprioceptive information was indexed via limb-position matching task. A near-frictionless, horizontally-mounted lever, the same used in training, was grasped in each hand (Figure 2 A). The experimenter supported the more involved arm at the elbow and drove the lever through eight continuous patterns of random movements. Participants closed their eyes and matched the movement of the driven arm by moving the opposite, less involved arm. Lever position measures were smoothed using a 100ms moving average and corrected for constant error. The area difference between the position of the driven and matching arms, root-mean-squared error

(RMSE<sup>5</sup>), was then calculated. Average RMSE for each CVA participant normalized to the mean HC RMSE was, taken as an index of the proprioceptive system's sensitivity (LPM<sup>6</sup>). Values above 1.0 reflect worse inter-limb matching than the average HC individual.

### *Outcome Measures*

For the motor learning task, lever position data were differentiated into velocity profiles and smoothed using a 100ms moving average (Koo et al. 2003) to reduce electrical noise. A correlation of target and arm velocity profiles was performed for each trial. Trials were excluded from analysis if the coefficient did not reach moderate strength ( $r=0.3$ ). (Aron and Aron 1999) Two participants were removed from analysis having tracked poorly in more than 50% of trials based on this criterion. For the remaining participants, less than 3% of trials were excluded. RMSE between target and arm velocity profiles was calculated separately for random and repeated sequence epochs. By using the present experimental paradigm, learning related to repetition of the sequence epoch can be separated from general motor control improvements captured by velocity RMSE on the random epoch. (Wulf and Schmidt 1997) Velocity RMSE was averaged for sets of 10 consecutive trials representing 1 block during the initial two days of training, and learning at retention. To more accurately reflect the task demands of the sequence epoch, we only considered random epochs for trials in which the average velocity of the target was within 2 standard deviations of the average

---

<sup>5</sup> RMSE =  $\text{SQRT}(\sum(x_i - X_i)^2/n)$  where  $x_i$  = driven arm velocity (or target velocity during sequence training) and  $X_i$  = matching arm velocity (or tracking arm velocity during sequence training).

<sup>6</sup> LPM =  $(\sum x_i/n) / \sum (\sum y_i/n)/r$  where  $x_i$  = limb matching trial RMSE for CVA group,  $y_i$  = limb matching trial RMSE for HC group,  $n$  = # of limb matching trials,  $r$  = # of HC participants

absolute random velocity of all trials. Thus, each random epoch block score is the average of approximately 9 trials.

To quantify sequence-specific learning we calculated the epoch-respective improvement in average RMSE. The difference between improvement on the random and sequence average RMSE change from Block 1 to Retention was considered the sequence-specific improvement score (SSI).

### *Statistical Analyses*

First, to examine baseline motor control and epoch differences, a two-way ANOVA of Group (CVA, HC) and Epoch (random, sequence) for Block 1 RMSE with repeated measures correction of Epoch was conducted. Tracking performance during training was assessed via three-way ANOVA (Epoch (random, sequence) x Block (1-10) x Group (CVA, HC)) with repeated measures correction for Epoch and Block. Sequence-specific learning was assessed at retention testing with two-way ANOVA (Epoch (random, sequence) x Group (CVA, HC)) with repeated measures correction of Epoch. Analyses were tested at  $\alpha=.02$ , corrected for multiple tests.

Pearson's product moment correlations were calculated between LPM or UEFM and random epoch RMSE at Block 1, to assess the relationship between tracking accuracy and sensorimotor function. To elucidate the relationship between continuous sequence learning and sensorimotor indices, correlation analyses were performed between LPM or UEFM and SSI. Correlations were tested at  $\alpha=.02$ , corrected for multiple tests.

#### *4.4 Results*

We asked participants to perform a continuous tracking task under conditions of limited visual feedback regarding performance, increasing dependence on proprioceptive signaling for accuracy. Embedded within each target movement pattern was a repeated pattern of velocity changes. We examined individuals' ability to learn this continuous sequence of movements through primarily proprioceptive feedback and the relationship between the integrity of the proprioceptive processing system and motor sequence learning.

##### *Practice Tracking Accuracy: Performance*

At the beginning of training (Block 1), before visual feedback of the position cursor was faded, no significant interaction or main effects of Group and Epoch were detected. Visual inspection of the data shows that over the course of the two training days though the HC group were better at tracking the target, all participants improved (decreased) tracking error with practice (Figure 4.2). In addition, both groups showed performance related improvement for the repeating sequence epoch as compared to random epochs (SSI HC=0.74, CVA=.23). These observations were confirmed via a three-way ANOVA which yielded an interaction of Block and Epoch ( $F(9,153)=7.80, p<0.01$ ). Greater performance accuracy (less overall error) was also noted for the HC group, evident in a main effect Group ( $F(1,17)=8.52, p=0.01$ ).

##### *Retention Test Tracking Accuracy: Learning*

The use of trials with random and repeated sequence segments allows us to differentiate sequence-specific learning from general task learning. At retention testing on

day 3, both groups exhibited learning of our continuous tracking task. This was evident in a main effect of Epoch ( $F(1,17)=29.91$ ,  $p<0.01$ ), demonstrating greater improvement for the repeating sequence epoch at retention as compared to random sequence tracking. The greater accuracy of the HC group noted during practice persisted ( $F(1,17)=10.39$ ,  $p<0.01$ ).

#### *Relationship Between Learning and Proprioception.*

As expected, the CVA group demonstrated greater overall error during limb position matching (average RMSE= $7.0 \pm 2.5$ ) than did the HC group ( $4.9 \pm 1.3$ ) ( $p=0.033$ ). The importance of proprioceptive integrity (LPM = average RMSE normalized to the HC group) for motor learning was illustrated by a strong and significant relationship between LPM and sequence specific learning (i.e., SSI) was detected,  $r=-0.74$  ( $p=0.015$ ; Figure 4.3a). The relationship between motor control and proprioception was strong and significant ( $r=0.83$ ,  $p=0.003$ ) (Figure 4.3b).

The relationship between arm motor function and the ability to learn continuous sequences of motion was also explored. Motor control as represented by tracking of initial random epochs was strongly related to arm motor function as indexed by the UEFM ( $r=-0.68$ ,  $p=0.030$ ) (Figure 4.4b); but interestingly, only a moderate but non-significant relationship was noted between arm motor function and not sequence-specific learning ( $r=0.46$ ,  $p=0.177$ ); Figure 4.4a.

As an additional, post-hoc check of motor function and performance we calculated the average absolute velocity for individuals across all trials. The average absolute velocity of target movement was 16.33 deg/s. The CVA group averaged  $16.05 \pm 0.56$  deg/s, which was not significantly different (t-test:  $p=0.17$ ) than the HC group,  $16.95 \pm 0.24$  deg/s. That velocity of movement was not a factor in expression of learning was further confirmed with

correlation analysis. Average absolute velocity was correlated with SSI, yielding no significant relationship ( $r=-0.1$ ,  $p=0.77$ ).

#### *4.5 Discussion*

Using a continuous tracking task and minimal visual feedback, we demonstrate here that individuals can learn a specific, repeating pattern of velocity changes over the course of several days of practice. Further, when the CNS is damaged, the magnitude of retained capacity to perceive and interpret limb movements is closely related to the ability to learn specific movement patterns. In contrast, motor function is related only to performance. Our findings support and extend previous research implicating proprioception in motor learning to include sequence-specific learning, in addition to previously described abilities to adapt familiar behaviors to novel environments, e.g. visual rotations or mechanical disruptions.(Krakauer et al. 1999; Pipereit et al. 2006; Verschueren et al. 1999) More importantly, the present research represents one of the first studies to examine the impact of damage to central proprioceptive processing structures on continuous motor sequence learning, extending previous work to human behavior.(Asanuma and Pavlides 1997)

#### *Motor Sequence Learning Task*

Throughout training and retention testing, the CVA group performed with greater error than the HC group. This is not surprising. Others have also reported worse performance during tracking tasks after stroke.(Boyd and Winstein 2006; Boyd and Winstein 2004a) Importantly, we employed an age-matched HC group. We and others have noted decreased sequence learning capacity with advancing age.(Boyd et al. in press; Shea et al. 2006) Therefore it was critical that our control group match our participants with stroke.

Initially, both groups performed equally well on the random and repeated epochs with sufficient visual feedback, suggesting that significant differences at retention were not the result of initially dissimilar performance. Over the course of practice, an epoch-wise performance effect became apparent. Prior tracking studies consistently report progressive spatial improvement specifically on the repeated portion of the skill with practice.(Pew 1974; Shea et al. 2001; Wulf and Schmidt 1997) The findings of the present study are no different despite our use of velocity profiles rather than spatially registered movement. Both groups were able to improve their general tracking ability and also to show better performance for the specific repeating sequence of velocity changes. Importantly, both group improved on the repeated, sequence portion of the tracking task to a greater extent than the random portion with practice.

Using a random tracking epoch at each trial as well as a separate retention test is critical for dissociating any effects of altered limb position sense on performance from the development of a learned plan for movement. Indeed, both groups demonstrated significant improvement on the sequence epoch as compared to the random at retention, supporting previous findings of preserved motor sequence learning capacity following stroke.(Boyd and Winstein 2003; Boyd and Winstein 2004b; Pohl et al. 2001; Vakil et al. 2000) Commonly, work investigating the role of proprioception for motor performance has only considered single time points.(Bernier et al. 2006; Bernier et al. 2007; Krakauer et al. 1999; Vercher et al. 2003) If we had employed such a design we may have not noted a relationship between motor learning related change and proprioceptive integrity. However, because we examined multiple days of practice and employed a delayed retention test we were able to discover that the magnitude of learning related change was directly related to the preservation of

proprioception as indexed via our limb matching task. In this manner learning versus performance improvements were clearly differentiated.(Salmoni et al. 1984)

To our knowledge, no prior studies of the role of proprioception in continuous sequence learning and proprioception following stroke have employed a separate retention test design. Therefore in the past it was not been clear whether disrupted central access to proprioceptive information would deleteriously impact motor learning. Taken together, these data indicate that the individuals with stroke who had poor proprioceptive ability were at a disadvantage during motor learning as compared to those with intact position sense.

#### *Sensorimotor-Learning Relationship*

The present study parallels, to the extent possible with humans, previous reports of disrupted novel skill learning following induced lesions to sensory cortex.(Pavlidis et al. 1993; Sakamoto et al. 1989) Proprioception is commonly considered to be important for motor skill learning. However, few if any studies have tested this in a cohort with a method that allowed for quantification of the magnitude of central disruption of proprioceptive perception. This is essential because work in non-human primates suggests that central and peripheral proprioceptive damage may impact skill learning differently.(Pavlidis et al. 1993; Taub et al. 1966)

As previously reported, proprioception was related to motor control as evidenced by a strong relationship between LPM and the accuracy of random epoch tracking (Figure 4.3b).(Rothwell et al. 1982; Smania et al. 2003) However, we also found that proprioceptive integrity was strongly related to learning to accurately track a repeated pattern of movement. Because our measure of sequence-specific learning (SSI) reflects improvement above and beyond general task learning, this findings argue against the suggestion that proprioception is

merely important for general motor control improvement. Rather, it appears that proprioception was crucial for tracking accuracy improvements specific to a repeating pattern of velocity changes. This is consistent with the previous suggestions that proprioception may be important for forming and helping to update a template of appropriate velocity-based motor command for successful execution of a motor skill.(Hwang et al. 2006a; Thoroughman and Shadmehr 1999).

The relationship between proprioception and skill learning stands in contrast to our findings concerning arm motor function. These results suggest that following stroke, arm motor function may be initially related to performance but this ability does not correlate with the ability to learn new skills. Rather, participants with poor motor function can learn and perform a continuous motor skill. Conversely, relatively good motor function in the more involved extremity following stroke is not a guarantee of the ability to learn a novel sequence. Because in the past, many studies of sequence learning following stroke required the use of the ipsilesional, less involved upper extremity,(Boyd and Winstein 2006; Boyd and Winstein 2003; Pohl et al. 2001) this relationship has been poorly characterized.

#### *An Internal Model of Movement Sequence?*

Currently, the most accepted theory of skilled motor learning and production is conceptually centered on the internal model.(Kawato and Wolpert 1998) Within the conceptual framework of the internal model, the body, environment and a plan for achieving the desired action are represented.(Kawato 1999; Vercher et al. 2003) Two components of the internal model have been proposed. The inverse model receives the desired and current, perceived state as input and computes a motor command to achieve that goal.(Kawato and Gomi 1992) The forward model predicts the likely outcome of an a planned or issued motor

command that can be used to correct movements online or during subsequent performance.(Davidson and Wolpert 2005) The maintenance of internal models of environmental forces and limb properties appear to be partly dependent on proprioceptive input as demonstrated by behavioral and computational data that suggest proprioception is integral for developing models for discrete, center-out, perturbed reaching.(Hwang et al. 2006b; Pipereit et al. 2006; Sober and Sabes 2003; Thoroughman and Shadmehr 1999) Thoroughman and Shadmehr (1999) proposed that proprioceptive signals might constitute a template that guides feedback-based learning. This error-response could ultimately become the inverse model that participates in generating appropriate motor commands. Consequent to refining movement is the learned pattern of familiar sensory expectations resulting from a correct movement, the forward model.(Blakemore et al. 2001; Blakemore et al. 2000; Witney et al. 1999) In the same manner, we suggest integrity of the proprioceptive system was crucial for developing both a set of motor commands (inverse model) and the template of predicted sensory outcomes necessary for correcting movements (forward model).

Krakauer and colleagues noted that internal models are developed both for the kinematics and kinetics of a discrete reaching task.(1999) It must be acknowledged, though, that the literature rarely refers to internal models of a kinematic sequence of movements such as the continuous tracking task used in the present study. A study by Waincott et al. (2005) addressed this question at least in part. By having participants perform a couplet of random movements in a force field, the authors demonstrated that inverse models of novel dynamics take into account the order of component and upcoming movements. The present data support and extend this work by demonstrating that continuous sequence learning depends to some extent on proprioceptive registration of movement, in the same way as models for discrete, perturbed reaching. Thus, a parsimonious explanation of continuous motor

sequence learning might dictate that complex movement patterns are indeed encoded in an internal model or a closely related set of models, that are concatenated and coordinated with practice.(Sakai et al. 2004) Though the present study is not a definitive statement on continuous sequence learning in a theoretical construct such as the internal model, it does demonstrate that sequences learning plays by similar rules to other work investigating the development of internal models for learned movements.

We suggest then, that individuals with damage to proprioceptive sensory processing areas resulting from stroke may experience difficult with encoding specific movement patterns, i.e. learning the internal model for movement. Though, many previous studies have placed the internal model within the cerebellum (Imamizu et al. 2003; Ito 2000), a few have considered the cerebral cortex to be important as well.(Decicco and Fisher 2005; Fisher et al. 2000) Specifically, we suggest that the use of proprioceptive information and the interaction of the sensorimotor areas is crucial for developing the internal model. This mirrors the elegant animal work demonstrating disrupted skill learning in animals with damaged sensory cortices.(Iriki et al. 1989; Pavlides et al. 1993).

### *Conclusion*

We recruited individuals with chronic stroke in the MCA distribution, which is known to process proprioceptive information centrally, and similarly aged healthy controls to perform a continuous motor sequence learning task. We controlled visual feedback and in this manner were able to examine the role of proprioception in motor sequence learning. Regardless of the presence of a stroke, all individuals were able to demonstrate behavioral change and thus show learning of the practiced pattern of continuous movements. However,

the integrity of the central proprioceptive processing system was closely related to continuous motor sequence learning, perhaps through the development of an internal model for the skill.

## Chapter 4 Tables and Figures

	Age	MMSE	UEFM	LPM	Lesion
CVA1	70	30	50	1.00	L Corona Radiata & Putamen
CVA2	67	29	59	0.96	L PLIC & Thalamus
CVA3	75	29	51	1.84	R Corona Radiata & Putamen
CVA4	45	28	60	0.98	L Occip. lobe, Parahippocampus & Thalamus
CVA5	60	25	54	1.41	R Temporal, Parietal, Insular & Occipital lobes
CVA6	65	28	51	1.48	R Corona Radiata, PLIC & Thalamus
CVA7	73	29	32	0.98	R Caudate, Corona Radiata, Putamen & PLIC
CVA8	32	28	25	1.35	<i>L Middle cerebral artery distribution</i>
CVA9	62	29	24	1.37	<i>Unavailable</i>
CVA10	66	29	56	0.71	<i>R Inferior Parietal &amp; Temporal lobes</i>
Avg. (SD)	61.5 (13.3)	28.4 (1.3)	46.2 (13.8)	1.21 (.3)	
HC1	61	29	--	--	--
HC2	62	30	--	--	--
HC3	59	30	--	--	--
HC4	30	30	--	--	--
HC5	66	30	--	--	--
HC6	73	29	--	--	--
HC7	63	30	--	--	--
HC8	46	30	--	--	--
HC9	63	30	--	--	--
Avg. (SD)	58.1 (12.7)	29.8 (0.4)	--	--	--

Table 4.1 Participant Characteristics

Individual characteristics and group averages (SD) including Age, Mini-Mental State Exam (MMSE) score, Upper Extremity Fugl-Meyer (UEFM) score and normalized Limb Position Matching index. Stroke location is also presented (PLIC = internal capsule, posterior limb). Location of the stroke based on prior imaging records for individuals unable to complete an MRI are presented in italics. CVA9 presented with clinical signs of a R MCA infarct, including L hemiparesis and increased muscle tone.

Figure 4.1 CVA Participant Lesions

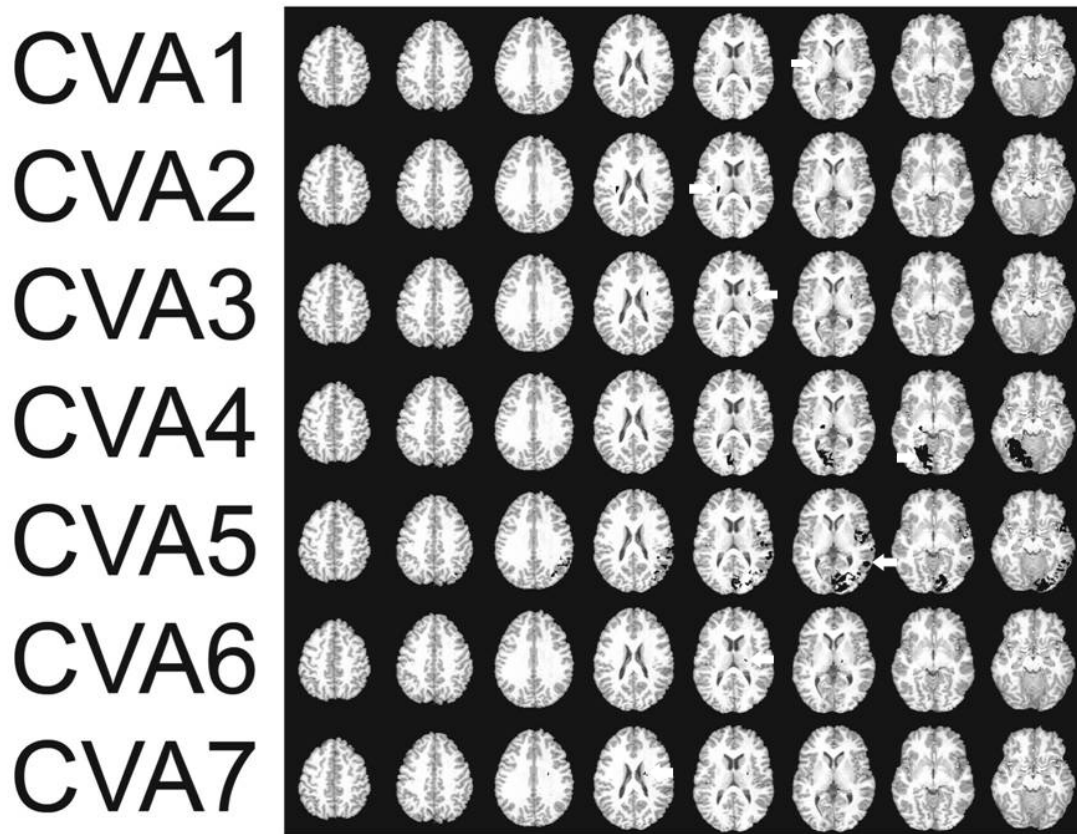

Lesion tracings in black overlaid on a healthy brain. All images are presented in stereotaxic space and are at 10mm intervals. Three participants were unable to undergo MRI. White arrows point at lesion on the slide nearest the centroid.

## 4.2 Tracking Accuracy

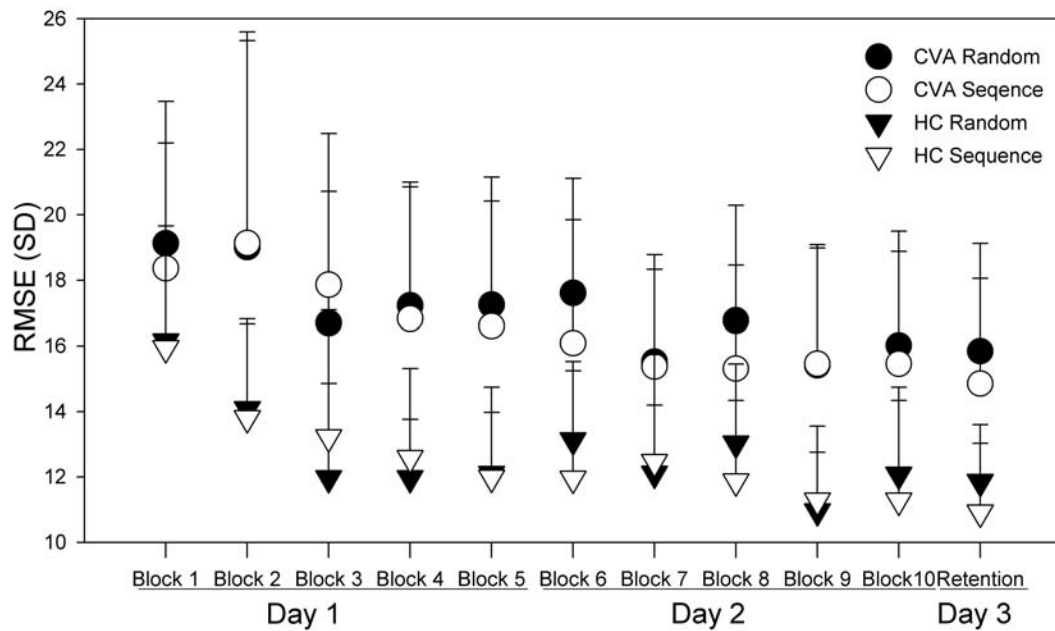

RMSE (SD) from velocity profiles over the course of training and retention testing for CVA (circles) and HC (triangles) participants. Throughout the study, the HC group was more accurate. At the beginning of practice, Block 1, there is no difference between random (black) and sequence (white) epochs. Over the course of training both groups improved on the sequence epoch to a greater extent than the random epoch. This improvement persisted at retention testing with both groups exhibiting sequence specific learning, demonstrating less error on the sequence epoch than the random.

### 4.3 Relationship Between Proprioception and Motor Learning

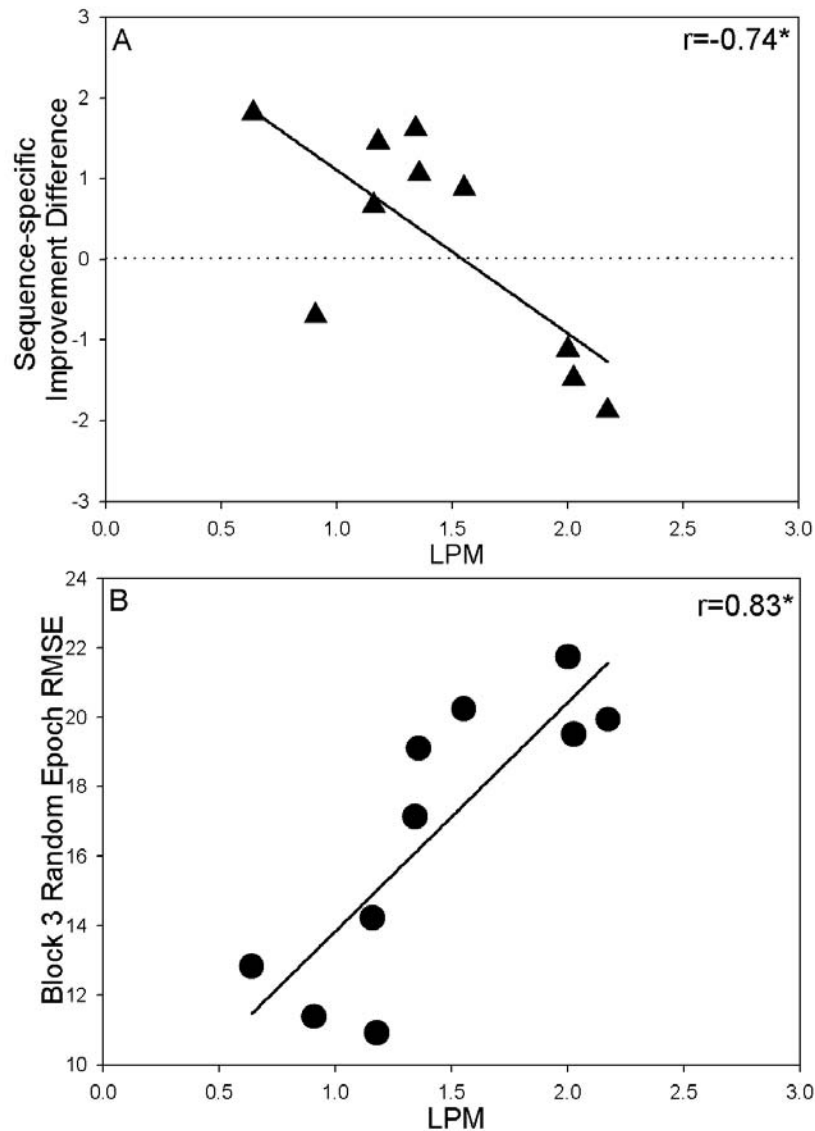

Proprioceptive integrity indexed as the normalized limb position matching RMSE (LPM) is plotted against the epochal difference in sequence-specific improvement over the course of practice (A). Increasing values of SSI represent greater improvement on the sequence epoch as compared to the random epoch. A strong relationship was detected between proprioceptive integrity and sequence learning ( $*p=0.015$ ). The horizontal dotted line represents the lower bound of the 95% CI for SSI. SSI values above this line fall within the

95%CI of HC SSI scores. LPM values greater than 1.0 represent worse matching error than the average HC participant. B) LPM is also plotted against Block 3 random epoch RMSE, a measure of motor control. LPM was significantly related initial random sequence tracking accuracy ( $p=0.003$ ). In pane B, decreasing ordinate values represent better tracking accuracy.

#### 4.4 Relationship Between Motor Function and Motor Learning

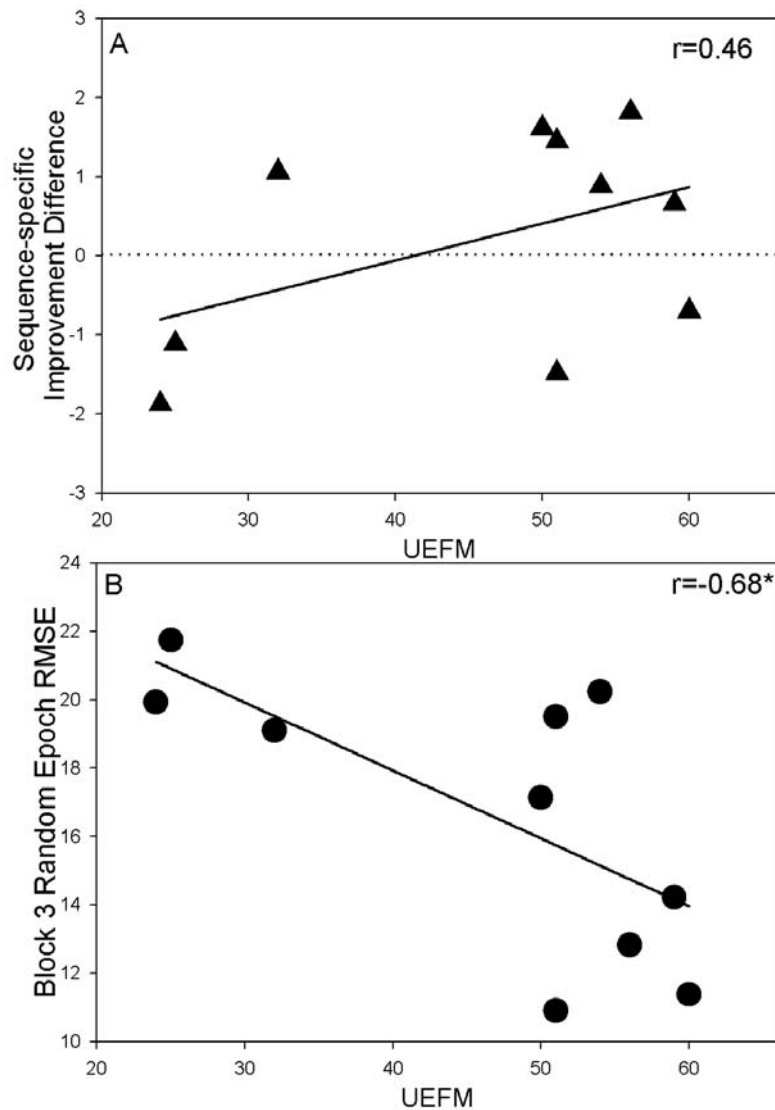

Motor function of the hemiparetic arm as indexed by the Upper Extremity Fugl-Meyer assessment (UEFM) is plotted against the epochal difference in sequence-specific improvement over the course of practice (A). A moderate ( $r=0.46$ ) but non-significant ( $p=0.177$ ) relationship between motor function and SSI was detected. As in Figure 4.3, increasing values of SSI represent greater improvement on the sequence epoch as compared to the random epoch. The horizontal dotted line represents the lower bound of the 95% CI

for HC SSI. B) The relationship between arm motor function (UEFM) and motor control ability as indexed by random sequence tracking. Early in practice, motor function was strongly related to motor control (\* $p=0.030$ ). In pane B, decreasing RMSE indicates better motor control and greater UEFM scores indicate better arm motor function.

## **Chapter 5 Preface**

The cerebellum is commonly considered to be one location of internal models and is believed to be significantly involved in the use of proprioceptive feedback and other sensory information for movement error evaluation to develop these models. Segregation of participants by lesion location, i.e. cortical and subcortical versus cerebellar, allow for differential examination of CNS damage and motor learning, especially the use of proprioception, for development of a motor plan or internal model of movement by these brain regions. The experimental paradigm used in Chapters 2 and 4 limits feedback primarily to that which can be gathered through proprioception. As such, it affords the opportunity to examine the use of proprioceptive signaling for motor learning, thought to be a possible function of the cerebellum. The following study explores the link between cerebellar use of proprioceptive feedback and motor sequence learning.

## **Chapter 5**

### **Preserved Continuous Motor Sequence Learning in Some Individuals with Cerebellar Pathology**

Vidoni, E.D., Boyd, L.A. Preserved Continuous Motor Sequence Learning in Some Individuals with Cerebellar Pathology. (to be submitted to Neurorehabilitation and Neural Repair, 2008)

### *5.1 Abstract*

The cerebellum is thought to play an essential role in movement optimization through several mechanisms including the evaluation of proprioceptive feedback. Additionally, the cerebellum appears to be important for adaptation to new environmental dynamics. However, studies have reported mixed results regarding the capacity for continuous motor sequence learning in those with cerebellar pathology. Owing to the cerebellum's role in somatosensory processing and its purported importance in motor learning, we engaged seven individuals with cerebellar pathology in a continuous tracking task under conditions which emphasized proprioceptive error evaluation. We also indexed participants' proprioceptive integrity using the LPM task described in previous chapters. Here we report evidence that supports preservation of sequence learning and execution capacity even in the more involved upper extremity of individuals with cerebellar pathology. We also identify a subset of individuals with cerebellar pathology that do not demonstrate continuous motor sequence learning. This dissociation may be a function of the scope of cerebellar damage in relationship to somatosensory feedback comparison.

## *5.2 Introduction*

Evidence demonstrates an essential role for the cerebellum in a variety of human activities. Individuals with damage to the central or vermal regions of the cerebellum often experience dysmetric, tremulous or poorly coordinated intentional movements.(Beppu et al. 1984; Lundy-Eckman 2002; Martin et al. 1996) Lesions in the lateral hemispheres, especially with the ventral posterior regions, are associated with cognitive and affective changes.(Exner et al. 2004; Schmahmann and Sherman 1998) These functionally disruptive signs may be a function of cerebellar responsibility for linking and coordinating components of movement or perhaps cognitive tasks.(Grossberg and Paine 2000; Thach 2007) Along with a role in movement optimization and cognition, evidence overwhelmingly identifies cerebellar participation in sensorimotor learning. The cerebellum has been implicated as a structure intimately involved in motor skill learning using a variety of experimental paradigms.(Imamizu et al. 2000; Morton and Bastian 2004a; Nowak et al. 2005) Based on these reports it appears that the cerebellum is important for adapting to changed environments, such as visual shifts. (Martin et al. 1996; Morton and Bastian 2004a; Richter et al. 2004) and predicting and automating movements based on a movement plan.(Lang and Bastian 2002; Nowak et al. 2005) This later function is often attributed to the cerebellum learning a forward model of movement.(Blakemore et al. 2001; Davidson and Wolpert 2005; Imamizu et al. 2000; Miall 1998)

Motor sequence learning is critical for daily function. Sequenced patterns of movement may be in the form of serial, discrete motions (e.g. typing) or more continuous movements, (e.g. cursive writing). Using a serial reaction time task (SRT) some have demonstrated the importance of the cerebellum for motor sequence learning,(Jenkins et al. 1994) including reports of disrupted learning in those with lesions (Gomez-Beldarrain et al.

1998; Molinari et al. 1997), perhaps for long term use and representation elsewhere in the brain.(Doyon et al. 2002; Nixon and Passingham 2000) However, studies of individuals with cerebellar damage do not present a united argument for or against cerebellar involvement in sequence learning. Gomez-Beldarrain and colleagues reported failure to learn a motor sequence when using the involved hand.(1998) Boyd and Winstein (2004a) reported spatial learning on a continuous tracking task but failure to improve temporal accuracy. This suggests that either the temporal representation or expression of movement is disrupted with cerebellar damage, but not necessarily the target motor goal.

A partial explanation of these noted differences may be the use of discrete (Gomez-Beldarrain et al. 1998; Molinari et al. 1997) versus continuous tasks.(Boyd and Winstein 2004a) Continuous sequence learning tasks require continuous coordination of movement parts.(Schmidt and Lee 1999b) It is known that interference with cerebellar function via cooling results in disruption of continuous tracking in animal studies.(Miall et al. 1987) The cerebellum may be especially important in coordinated behaviors such as learning to coordinate muscle synergies and to produce meaningful outcomes such as calligraphic writing.(Paine et al. 2004) In movements that require more precise execution, motor plans may be evaluated based on expected versus actual sensory outcome, especially through proprioception and vision.(Hwang and Shadmehr 2005; Thoroughman and Shadmehr, 2000)

Extensive innervations from both peripheral sensory receptors and cortical structures in the cerebellum,(Allen et al. 1977; Allen et al. 1978; Bloedel 1973) as well as the homogenous and well studied cellular structure make it a consensus structure of error-feedback learning.(Ito 2005) Further, evidence argues for a cerebellar role in detecting changes in somatosensory input,(Liu et al. 2000; Restuccia et al. 2007) as well as processing of movement information.(Jueptner and Weiller 1998; Naito et al. 2007; Ramnani

et al. 2000) In the absence of reliable visual information, movement error evaluation would be driven primarily by proprioception. Therefore, we hypothesized that individuals with damage to cerebellar structures would demonstrate impaired but not abolished sequence learning of a motor skill when proprioception was the primary source of feedback available to aid motor performance and learning. We employed a continuous tracking task with an embedded repeated sequence or epoch. Participants were asked to repeatedly practice a pattern of movements, requiring continuous evaluation of proprioceptive error to optimize motor performance, without continuous visual feedback. In this manner, participants would derive feedback and update motor commands regarding performance primarily by comparing expected somatosensory outcomes with perceived outcomes.

The present study builds on the previous work by examining the use of afferent information by cerebellar patients during continuous motor sequence learning. It has been suggested that proprioception is important learning new motor patterns,(Hwang and Shadmehr 2005) and that the cerebellum is a necessary region for the evaluation of sensory patterns related to learning skilled behavior.(Ito 2005; Kawato and Gomi 1992) However, this study differs from previous work in several important ways. First, unlike our prior continuous tracking experiment,(Boyd and Winstein 2004a) participants used the more involved arm and were not provided with continuous visual feedback. Second, in contrast to previous studies (Gomez-Beldarrain et al. 1998; Molinari et al. 1997; Morton and Bastian 2004a; Seidler et al. 2002), we employed a retention test on a separate testing day to differentiate motor learning from performance improvements.(Salmoni et al. 1984) In this manner, learning is more reliably characterized as a relatively permanent change in behavior.(Schmidt and Lee 1999a)

### *5.3 Methods*

#### *Participants*

Eight individuals with cerebellar damage (CB) and 7 age-matched ( $\leq 5$  yrs) individuals with no reported history of brain damage (HC) provided institutionally approved informed consent. The performance of some HC participants was also reported in Chapter 4. All participants scored at least 26/30 on the Mini-Mental State exam (MMSE), indicating no evidence of dementia. Vision for all participants was corrected to at least 20/40 on near vision assessment. Motor ataxia in the CB group was quantified using the Scale for the Assessment and Rating of Ataxia (SARA). (Schmitz-Hubsch et al. 2006) No significant difference was found between groups for age ( $p=0.785$ ) or MMSE ( $p=0.105$ ).

Because of the difficulty in recruiting a uniform cohort of individuals with cerebellar damage, multiple etiologies were included. (Harrington et al. 2004; Morton and Bastian 2004b; Richter et al. 2004) Four CB individuals participated at least 6mo after one-time cerebellar stroke (CVA group). One CB participant had experienced a pons stroke and presented with clinical signs of cerebellar damage. Two individuals had significant cerebellar atrophy. One participant withdrew from the study prior to its conclusion secondary to perceived difficulty of the task. Her data were not included in our analyses. Individuals were compensated for travel expenses. Participant characteristics and cerebellar damage are summarized in Table 5.1.

#### *Location of Cerebellar Pathology*

Neuroanatomical scans were obtained for 5 CB participants. A pre-existing MRI or CT report was obtained for the remaining two individuals. T1 anatomical scans were converted to Talairach stereotaxic coordinates using AFNI software. (Cox 1996) Lesions

were traced using MRIcro software to visually present the data when it was available.(C. Rorden, Columbia, SC) Location of pathology is described in Table 5.1 using terminology from Schmammann et al.(2000)

### *Motor Learning Task*

Seated in front of a computer monitor, participants engaged in continuous tracking of a target moving in a sine-cosine waveform (Pew 1974; Wulf and Schmidt 1997) using either their dominant arm (HC) (Oldfield 1971) or their more impaired, ipsilesional arm (CB). (The participant with a pons lesion used the contralesional arm). The task used in the present study was similar to that reported previously (Vidoni and Boyd, 2007; see also Chapters 2 & 4) and involved shoulder/elbow flexion and extension to move an on-screen cursor with a horizontally mounted lever restricted to motion in the transverse plane. The hand was stabilized on the lever (using an elastic wrap for 1 participant). Participants tracked a white square target with a yellow circle cursor. All individuals were able to achieve the necessary range of motion to accurately perform the task (31cm of angular deflection). Lever position sampling and all stimuli were presented at 40Hz using custom software developed on the LabView platform (v. 7.1; National Instruments, Austin, TX).

We modified a method reported by Wulf and Schmidt (1997) to construct target movement patterns. A unique 33s trial was constructed from one 3s baseline and two 15s sine-cosine waveforms, or “epochs.” During each trial, participants tracked a novel, random epoch and a sequence epoch, common to each trial. The presentation of the sequence epoch, first or last in each trial, was randomized to minimize order effects. The same trial order was employed for every participant for purposes of comparison over practice. Participants were

not informed of the repetition but instructed only to track the target as accurately as possible at all times by controlling the yellow cursor with the lever.

### *Training Paradigm*

Individuals practiced the tracking task 50 trials a day for two days and returned on third day for 10 retention test trials. To maximize dependence on somatosensory information, visual feedback of movements was severely restricted. Draping was hung above participant's upper body to prevent vision of the arms. Additionally, over the first 20 practice trials, visual feedback regarding lever position was faded (Vidoni and Boyd 2007) from continuous presentation on trial 1, to a 200ms duration presentation every 2s by trial 19. At this intermittency, visual feedback has been previously shown to be not useful for guiding continuous hand-controlled cursor movements.(Kao 1976) To motivate individuals, we provided summary feedback regarding overall tracking accuracy following each trial as a percentage of time the position cursor spent within a 10° bandwidth of the target. This score did not contain sufficient information to alter performance characteristics or reliably improve tracking on the sequence epoch and was therefore provided on all days including retention.

### *Outcome Measures*

Lever velocity profiles were smoothed using a 100ms moving average. The area difference between target and participant velocity, root-mean-squared error (RMSE)<sup>7</sup>, was calculated separately for random and sequence epochs. RMSE was averaged for sets of 10 consecutive trials representing 1 block during the initial two days of training, and learning at retention. Because cerebellar damage has been linked to errors of movement timing, we

---

<sup>7</sup> RMSE = SQRT( $\sum(x_i - X_i)^2/n$ ) where  $x_i$  = probe velocity,  $X_i$  = target velocity

additionally employed cross correlation time series analysis (Boyd and Winstein 2004b; Day and Marsden 1982) to examine spatial and temporal changes in tracking accuracy. To more accurately reflect the task demands of the sequence epoch, we only considered random epochs with an average velocity within 2 standard deviations of the average absolute random velocity. Thus, each random epoch block score is the average of approximately 9 trials. Trials were also excluded from any analysis if the peak correlation coefficient for either the sequence or random epoch did not reach moderate strength,  $r=0.3$ .(Aron and Aron 1999) The difference between real-time and peak correlation coefficients of temporal tracking accuracy represents time lag of tracking. The original tracking position data were shifted by this lag and RMSE was recalculated to produce a “lag-corrected” measure of spatial accuracy.

To quantify sequence-specific learning we calculated the epoch-respective improvement in average, lag-corrected RMSE. The difference between improvement on the random and sequence average RMSE change from Block 1 to Retention was considered the sequence-specific improvement score (SSI).

### *Indexing of Proprioception*

As in Chapter 4, the ability to access and discriminate proprioceptive feedback was indexed via a limb-position matching task. (One CB-L participant did not complete this portion of the study at the time of writing this manuscript.) The experimenter supported the more involved arm at the elbow and drove the lever through eight continuous patterns of random movements. Participants closed their eyes and matched the movement of the driven arm by moving the opposite, less involved arm. Lever position measures were smoothed using a 100ms moving average and corrected for constant error. The area difference between

the position of the driven and matching arms, root-mean-squared error (RMSE<sup>8</sup>), was then calculated. Average RMSE for each CVA participant normalized to the mean HC RMSE was, taken as an index of the proprioceptive system's integrity.

### *Statistical Analyses*

Visual inspection of the data suggested two subgroups of CB participants based on variability in SSI. Using the lower bound of the 95% confidence interval for HC SSI as a threshold we divided CB participants into learners (CB-L, n=5) and non-learners (CB-N, n=2). As will be presented in the discussion, the two CB-N participants had by far the largest lesions, encompassing the greatest amount of cerebellar cortex, providing neuroanatomical support for this division.

First, to ensure no baseline differences in task demands were present, a two-way repeated measures ANOVA of Epoch (random, sequence) x Group (CB-L, CB-N, HC) was conducted on real-time RMSE. To separate change in tracking associated with improved motor control or non-specific learning from more permanent changes in behavior as a result of sequence-specific learning we subjected SSI to a one-way ANOVA of Group.

Because real-time and lag-corrected spatial error block averages were closely related ( $r > 0.9$ ) we have chosen to present only the component elements of time lag and lag-corrected RMSE to simplify interpretation of training and retention data. For each component element, tracking practice was assessed via three-way ANOVA (Epoch (random, sequence) x Block (1-10) x Group) with repeated measures correction for Epoch and Block. Sequence-specific

---

<sup>8</sup> RMSE =  $\text{SQRT}(\sum(x_i - X_i)^2/n)$  where  $x_i$  = driven arm velocity (or target velocity during sequence training) and  $X_i$  = matching arm velocity (or tracking arm velocity during sequence training).

learning was assessed at retention testing using an Epoch x Group ANOVA with repeated measures correction of Epoch for each of our dependent measures. ANOVAs were tested at  $\alpha=0.02$ , and reported with partial eta-squared values ( $P\eta^2$ ). Greenhouse-Geisser correction was employed when sphericity was violated. Post-hoc least-squares difference (LSD) and Student's t-tests were performed to further characterize significant effects.

#### *5.4 Results*

In general, individuals in the HC group were able to learn a specific, continuous sequence of movements despite deprivation of visual feedback while only some individuals with cerebellar pathology were able to demonstrate learning of spatial sequence parameters. Consistent with the literature,(Boyd and Winstein 2004a) individuals with cerebellar stroke who learned the task had poor temporal tracking accuracy that persisted throughout training. In contrast, individuals with cerebellar damage who were unable to learn the sequencing task and who had the largest lesions exhibited less tracking lag with practice. However, this improvement in timing came at a cost of generally worse spatial accuracy and had a negative influence on overall tracking accuracy.

#### *Real-time Tracking Velocity Accuracy*

At the start of practice, tracking accuracy was no different on random and sequence epochs ( $p=0.723$ ) indicating no inherent, initial differences between the waveform component sections. Nor did groups significantly differ on tracking performance ( $p=0.312$ ). However, at retention groups differed significantly regarding the sequence-specific learning they demonstrated. We used SSI as a measure of practice related sequence-specific improvement from Block 1 to retention testing. A significant main effect of Group was found,

( $F(2,11)=7.217$ ,  $p=0.01$ ;  $P\eta^2=0.56$ ), Follow-up LSD analysis revealed this effect stemmed from both the CB-L ( $p=0.027$ ) and HC ( $p=0.003$ ) groups' tracking improvements differing from that of the CB-N group.

#### *Lag-corrected Velocity Tracking Accuracy*

We corrected individuals' velocity profiles to account for inherent sensorimotor delays through time series analysis. This measure reflects strictly error in the movement velocity pattern. Over the course of the first two blocks, lag-corrected velocity error progressively improved for all participants as they became familiar with the task. Visual inspection suggests that after initial improvements CB-N trended towards greater tracking error whereas both CB-L and HC groups maintained improved performance (Figure 5.3). Three-way ANOVA revealed an Epoch by Block interaction ( $F(9,99)=4.286$ ,  $p=0.004$ ;  $P\eta^2 = 0.28$ ) during the first two days of practice. This is likely a function of greater improvement on sequence epoch tracking than on the random epoch with practice, especially by the CB-L and HC groups (Figure 5.2 a & c).

Improvements in tracking made by the CB-L and HC groups persisted at retention testing. ANOVA revealed a significant Epoch x Group  $F(2,11)=12.839$ ,  $p=0.001$ ;  $P\eta^2 = 0.700$ ) interaction. Post-hoc, pairwise t-testing confirmed that both HC ( $p=0.003$ ) and CB-L ( $p=0.023$ ) participants improved tracking on the sequence epoch. The CB-N group did not demonstrate sequence learning ( $p=0.315$ ). Additionally, post-hoc LSD detected significantly less tracking error on the part of HC participants as compared to the CB-N group ( $p=.02$ ).

### *Temporal Accuracy*

Though visual inspection would suggest that both the HC and CB-N groups decreased their lag in movement velocity tracking with practice, no main or interaction Block ( $p=.027$ ) or Epoch ( $p=.296$ ) effect was found to be significant with sphericity correction. Instead, a main effect of Group ( $F(2,11)=7.295$ ,  $p=0.011$ ;  $P\eta^2 = 0.57$ ) was detected stemming from significantly worse lag on the part of CB-L participants than the HC group ( $p=0.003$ ) (Figure 5.3).

At retention, Group differences remained significant ( $F(2,11)=9.545$ ,  $p=0.004$ ;  $P\eta^2=0.634$ ). Again, the CB-L group demonstrated worse temporal accuracy of movement velocity than either of the two other groups, (HC  $p=0.002$ , CB-N  $p=0.007$ ). HC participant movements lagged behind the target by an average of 37.3ms at retention testing. Similarly, the two CB-N participants lagged behind by 56.3ms. By contrast, individuals with cerebellar damage who otherwise learned the task never decreased their lag time, averaging 177.2ms lag at retention testing. Considering previous reports of temporal movement disruption with cerebellar damage (Boyd and Winstein 2004a) it is important to note that at least one participant in the CB-N admitted to a strategy of target movement anticipation “just to keep up.” It is possible that one or both of these participants, rather than learning movement velocities, guessed where to go next, resulting in ultimately worse tracking performance that made temporal “improvements” inconsequential.

### *Sensorimotor Characteristics*

Several distinct characteristics are important to the interpretation of these data. First, we indexed the integrity of proprioceptive discrimination using a clinically common limb

position matching task. CB-L participants had similar LPM measures as neurologically intact individuals, (HC  $1.0 \pm 0.26$ , CB-L  $1.16 \pm 0.49$ ). In contrast, the CB-N group had worse proprioception ( $1.7 \pm 0.37$ ). This Group effect trended towards significance ( $F(2,11)=3.272$ ,  $p=0.077$ ;  $P\eta^2=0.971$ ). Additionally, worse ataxia, as measured by the SARA, was seen in CB-N participants compared to those in the CB-L group (CB-L  $6.3 \pm 2.5$ , CB-N  $16 \pm 0$ ) ( $F(1,5)=26.049$ ,  $p=0.004$ ;  $P\eta^2=1.87$ ). Finally, the CB-N group was distinguished by larger lesions that encompassed substantial portions of the cerebellar cortex including lobes IV through VI.

As an additional, post-hoc check of motor function and performance we calculated the average absolute velocity for individuals across all trials. The average absolute velocity of target movement was 16.33 deg/s. The CB-L group averaged 16.78 deg/s, and the CB-N averaged 11.06 deg/s. The HC group moved with an absolute average velocity of 16.95 deg/s. One-way ANOVA revealed that the CB-N group was significantly slower ( $F(1,5)=28.637$ ,  $p=0.003$ ;  $P\eta^2=0.663$ ) than either the CB-L participants ( $p=0.004$ ) or the HC group ( $p=0.003$ ) based on Bonferroni post-hoc analysis.

### *5.5 Discussion*

The experimental paradigm used in this study affords the opportunity to examine the use of proprioceptive signaling for motor learning, thought to be a possible function of the cerebellum. (Kawato and Gomi 1992; Ramnani et al. 2001) Because visual information regarding tracking movements was severely restricted, proprioception was a primary source of feedback for evaluation of what movement outcome was expected versus what was perceived. Consistent with the literature, (Pew 1974; Wulf et al. 1999) healthy individuals demonstrated sequence-specific learning of a pattern of movements as demonstrated by

reduced velocity error over the course of training. In contrast to previous reports (Gomez-Beldarrain et al. 1998) we found that some individuals with cerebellar pathology were able to learn a movement pattern with the more involved arm. Despite the ability to track accurately in space, the individuals in the CB-L group, were consistently worse at timing their tracking movements appropriately.

The performance of the CB-L group agrees with our previous work (Boyd and Winstein 2004a) as well as previous suggestions that the cerebellum participates in the appropriate temporal coordination of movements. (Ivry et al. 1988; Ramnani et al. 2001) Cerebellar learners tended to display less ataxic movement and kinesthetic accuracy equal to that of individuals with no lesion. These individuals also tended to have smaller lesions and pathology sparing the lateral hemispheric cortex (see Table 5.1).

Despite improved performance over the course of practice, not all individuals with cerebellar pathology demonstrated sequence-specific learning. Two individuals did not demonstrate sequence-specific improvement over the course of practice in either the temporal or velocity profile domain. Rather, tracking lag decreased at the cost of worse tracking velocity error. One participant admitted to attempting a strategy of anticipatory movements. This strategy may have resulted in the participant moving with in advance to a position then holding there. This would give the *appearance* of anticipation as well as artificially decrease average velocity measures. The opportunity-cost of this may have been sequence-specific learning. It is possible that in an effort to anticipate upcoming motions, accurate spatial repetition of sequence motions was marginalized. It is also possible that any possible sequence or non-specific task learning was simply masked by the highly variable performance of these participants. That is, even if sequence characteristics were encoded in

some manner, poor motor performance could obscure execution and failure to express learning.

Individuals in the CB-N group had the highest SARA scores (greatest ataxia) of the CB cohort and lesions that encompassed portions of the lateral hemispheric cortex. In one case, CB-N2, a complete cerebellar hemispherectomy was performed following stroke. Though future work will need to confirm our findings, it appears that extensive damage that includes the lateral cerebellar cortex may either inhibit or obscure the expression of continuous motor sequence learning.

#### *Proprioception and the Cerebellum*

Because we limited visual feedback of movement error as well as indexed proprioceptive integrity we were able to examine the somatosensory error-feedback learning loop of a continuous movement sequence. The individuals in the CB-N group displayed worse limb position matching ability than the CB-L and HC groups. This is consistent with work suggesting the lateral hemispheres are integral to sensory discrimination.(Gao et al. 1996; Parsons et al. 1997) Some evidence even suggests that the cerebellum, specifically the lateral cortices are involved in conscious somatosensory error detection.(Liu et al. 2000; Restuccia et al. 2007) Therefore, consistent with prior work,(Jueptner and Weiller 1998) we suggest that the failure of the CB-N to learn the movement sequence in this study was, in part, a consequence of disrupted sensory discrimination and feedback-based learning. We propose that these individuals were unable to develop a refined pattern of movement based on error between feedback and expectation as a result of greater cortical involvement in two participants. This was a direct result of widespread cerebellar damage encompassing the lateral hemispheres critical for sensory error detection.

### *Implications for Motor Sequence Learning*

Grossberg and Paine (2000) have proposed a model (AVITEWRITE) of continuous sequential movement learning, such as cursive handwriting, whereby the cerebellum learns to coordinate a pattern of overlapping changes of bell-shaped velocity profiles. The required effector speed and direction are encoded by the motor and premotor cortex. (Schwartz and Moran 1999) Then the necessary changes in velocity are appropriately timed, or coordinated, for upcoming pen strokes by the cerebellum. There is some disagreement as to whether these deficits are related to timekeeping (Ivry et al. 1988; Schlerf et al. 2007) or are coordination and execution related. (Diedrichsen et al. 2007; Harrington et al. 2004) Though our outcome measures do not elucidate this difference of opinion, they do confirm a failure to improve temporally coordinated movement with practice following cerebellar damage.

This purported role of the cerebellum posited by Grossberg and Paine (2000) fits well with previous reports of disordered temporal execution (Bares et al. 2007; Boyd and Winstein 2004a; Miall et al. 1987; Schlerf et al. 2007) as well as the findings of the present study. As expected, individuals with intact cerebella (HC) demonstrated sequence-specific improvement in tracking velocity by retention testing, despite being forced to evaluate and update movement plans primarily through proprioceptive evaluation and repetition. In contrast those with cerebellar pathology who demonstrated learning of the movement velocity pattern were unable to improve execution temporally. Those that tried to anticipate target movement (CB-N participants) did so at the cost of sequence-specific learning.

Though Grossberg and Paine speak directly to the use of visuomotor signaling via climbing fibers, there seems to be no reason why proprioceptive signaling could not serve a similar feedback learning purpose. The cerebellum enjoys access to proprioceptive

information via olivary climbing fibers (Bloedel 1973) and should theoretically be able to tune patterns of Purkinje cell firing via LTD.(Ito 2000) Indeed, strong evidence exists for the cerebellum playing important role in sensory processing during movement.(Jueptner et al. 1997; Jueptner and Weiller 1998; Ramnani et al. 2000) This also fits closely with internal model theory. (Kawato and Gomi 1992; Wolpert et al. 1995) in which evaluation of sensory feedback is used to update movements and encode movement plans in expected sensory outcomes.(Hwang and Shadmehr 2005; Thoroughman and Shadmehr 1999) Indeed, some researchers have placed the internal model wholly within the cerebellar hemispheres.(Imamizu et al. 2000)

Based on the present findings and past work we suggest that the cerebellum is critical for learning to predicatively coordinate and perhaps concatenate (Sakai et al. 2004) movement segments (Krebs et al. 1999) to produce functional motor behaviors. These predictions are made in terms of the sensory consequences the movement engenders, accounting for the close association between the cerebellum and the forward model.(Blakemore et al. 2001; Fisher et al. 2006). Learning to predict precise coordination of movement segments results in the creation of an inverse model, also often associated with the cerebellum. Continued activation of the cerebellum even after over-practice,(Imamizu et al. 2000) may then reflect the continued role of the cerebellum in appropriately coordinating movement sequence segments to produce the desired behavior. The findings of the present work suggest regional cerebellar activity for encoding of coordination patterns for movement sequences based on error-feedback evaluation as well as executing those coordinated movement patterns. We suggest that the lateral cerebellum is important for learning predictive coordinative control of continuous motor sequences.

### *Conclusion*

We report here that some individuals with cerebellar damage were able to learn a continuous repeated sequence of arm movements with the more involved extremity when we accounted for temporal coordination errors. Those who were unable to learn the pattern had worse proprioceptive discrimination and lesions that encompassed the cerebellar cortex. These findings support previous work regarding the role of the lateral cerebellar hemispheres in sensory discrimination. It also presents preliminary evidence for a role of the lateral cerebellar regions in learning of specific movement sequences based on proprioceptive error-feedback learning. This may include learning to coordinate execution of one or more internal model for a movement sequence.

	Age	SARA	Lesion	Size (cc)
CB-L1	70	4	<i>B Cortical Atrophy</i>	--
CB-L2	58	9	R Lobule V, VI & Crus I CVA	0.3
CB-L3	42	4	L Pontine CVA	0.2
CB-L4	75	5.5	R Enlarged Superior Posterior Fissure	1.0
CB-L5	56	9	L Crus I & II CVA	3.1
CB-N1	68	16	R Lobule III-VI, Crus I and associated white matter CVA	12.7
CB-N2	56	16	<i>L Cerebellar Hemispherectomy following CVA</i>	--
Avg. (SD)	61.5 (12)	9.1 (5.7)		
HC1	61	--	--	--
HC2	62	--	--	--
HC3	59	--	--	--
HC4	66	--	--	--
HC5	73	--	--	--
HC7	46	--	--	--
HC8	67	--	--	--
Avg. (SD)	62 (8.4)	--	--	--

Table 5.1 Participant Characteristics

Individual characteristics and group averages (SD) including Age and Scale for the Assessment and Rating of Ataxia (SARA). A description of cerebellar pathology is also presented. For individuals with an available MR study, locations of damage are reported according to the conventions of the Schmahmann Atlas.(Schmahmann et al. 2000) Descriptions based on medical records for individuals unable to complete an MRI are presented in italics. Lesion size is presented in cubic centimeters (cc).

Figure 5.1 Cerebellar Pathology

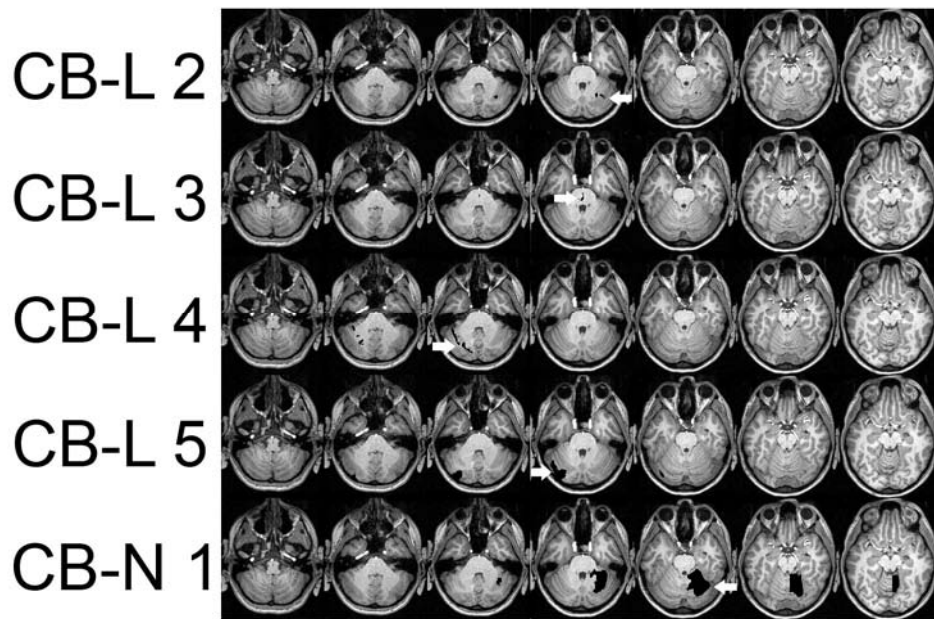

Lesion tracings in black overlaid on an exemplar brain. All images are presented in stereotaxic space and are at 5mm intervals. Three participants were unable to undergo MRI. A white arrow points to the lesion. Studies are labeled by group (CB-L, CB-N) and are matched to Table 5.1.

Figure 5.2 Lag-corrected Velocity Tracking Accuracy

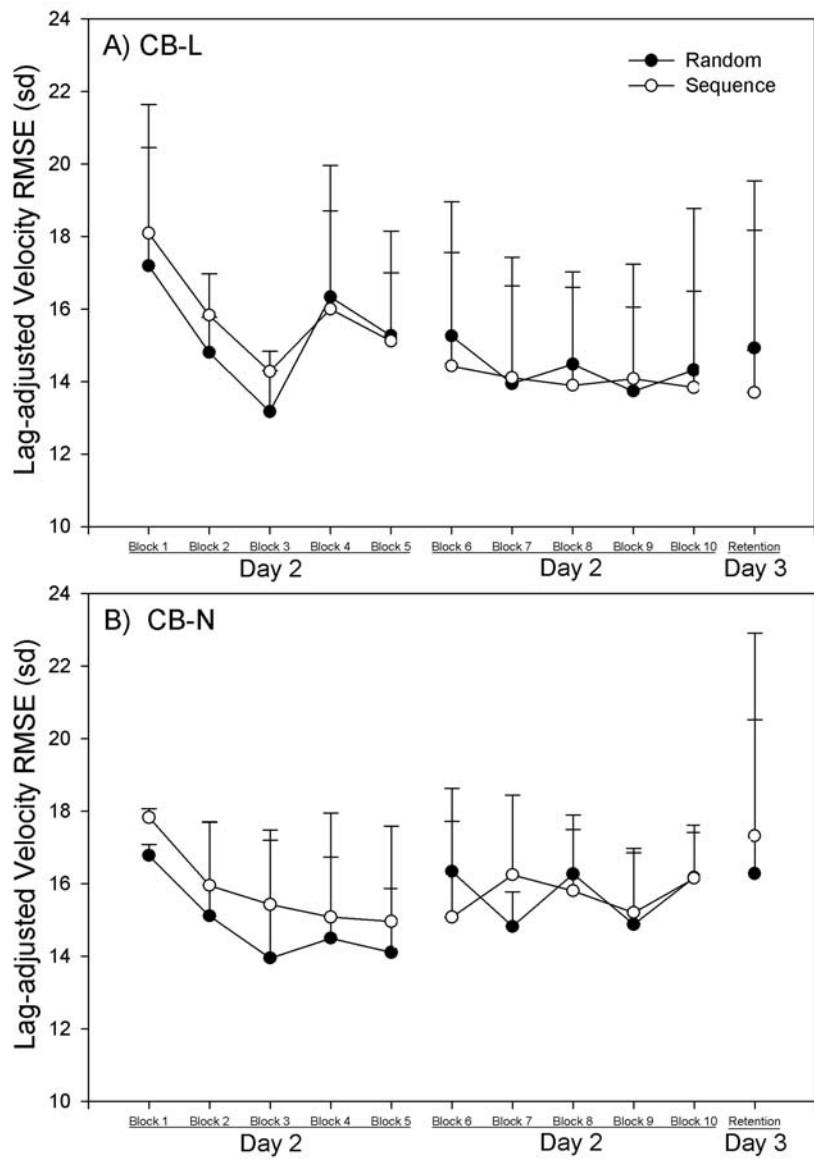

## 5.2 Lag-corrected Velocity Tracking Accuracy continued

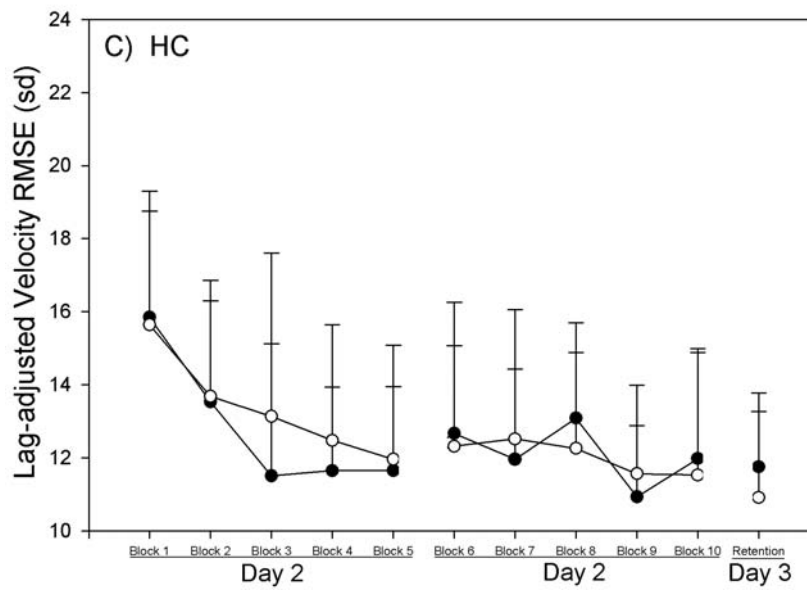

Accuracy of tracking velocity in RMSE is plotted in over the course of practice (Blocks 1-10) and at retention testing. At retention both CB-L (A) and HC (C) participants demonstrate sequence-specific learning. Cerebellar non-learners (B) do not demonstrate sequence-specific learning.

Figure 5.3 Temporal Accuracy

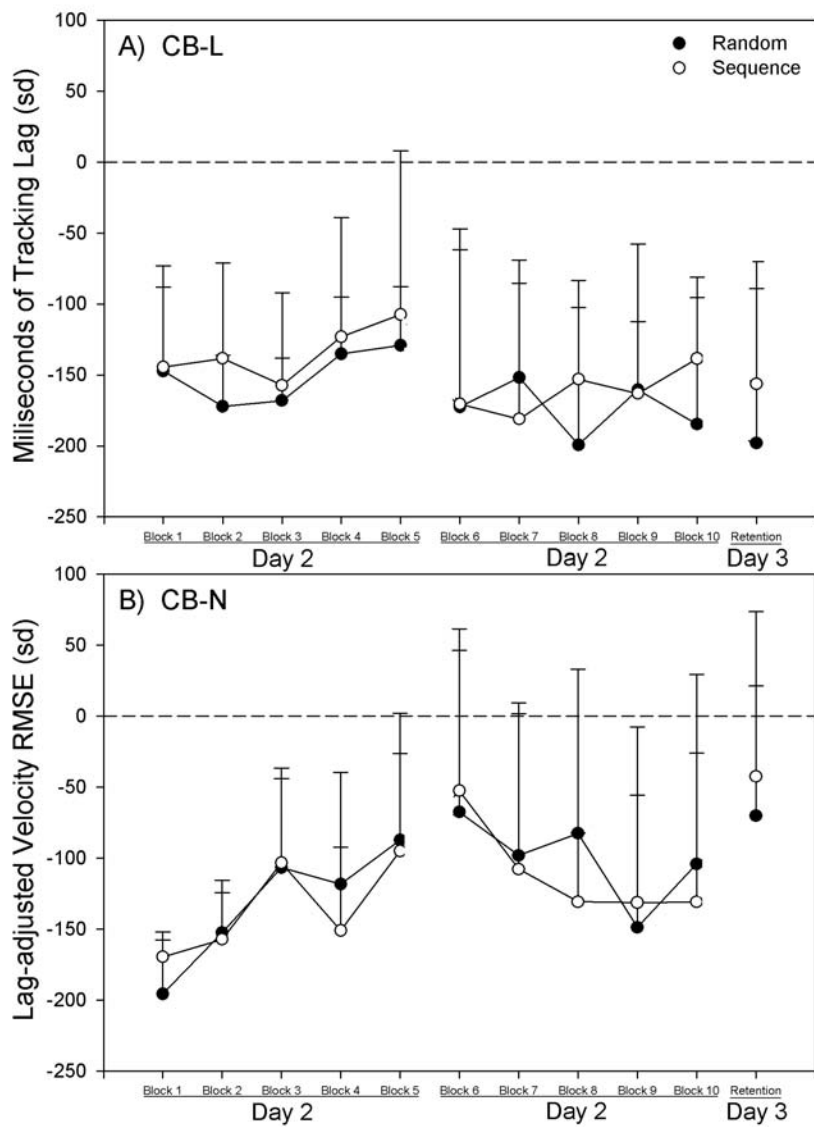

### 5.3 Temporal Accuracy (continued)

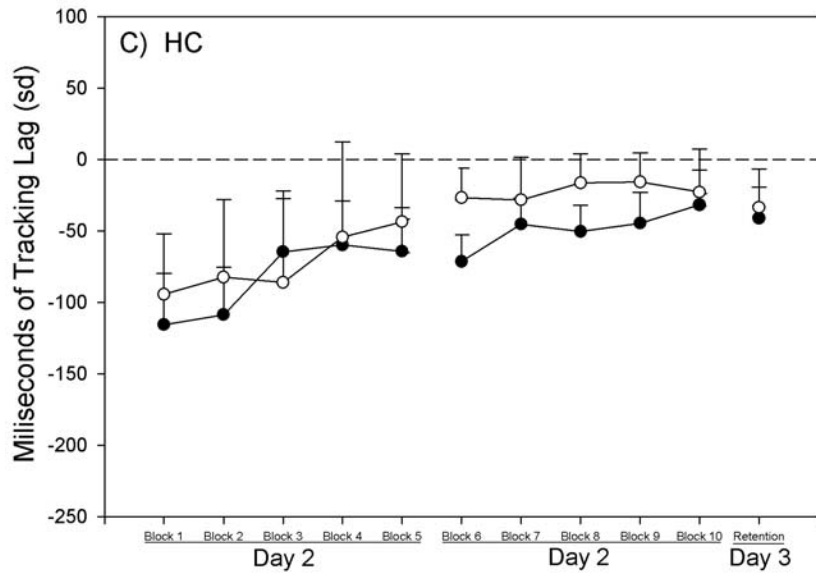

Lag in velocity changes plotted in milliseconds over the course of practice and at retention testing. The dashed line indicates perfect temporal correlation between the velocity of the target and arm movement. No group makes a sequence-specific improvement in timing. Cerebellar learners (A) do not appear to improve tracking lag at all, consistent with previous literature. Cerebellar non-learners (B) and healthy participants (C) appear to decrease lag. However, these practice-related timing improvements did not reach significance. At all times during the experiment, the CB-L group demonstrated worse temporal error than the HC group.

## **Chapter 6**

### **Discussion and Conclusions**

### *6.1 Summary of Findings*

The work presented here was primarily undertaken to help characterize the role of proprioception in motor learning. Specifically, this research extends the literature firmly into the realm of motor sequence learning by employing a whole arm novel continuous motor pattern and a delayed retention test. Further, these experiments represent some of the first investigations of continuous motor sequence learning on those with sensory impairment as a function of central nervous system damage. The findings presented suggest that the impact of peripheral versus central damage on motor learning may be different. Possible reasons for this will be discussed later in this section. Differentiated findings such as these are important both to guide motor learning theory and rehabilitation practice. Through this work and the follow-up studies beyond, it is hoped that a better understanding of the challenges faced by those with impaired proprioceptive function will be gained.

### *Chapter 2. Motor Sequence Learning Occurs Despite Disrupted Visual and Proprioceptive Feedback*

The primary aim of the experiments in Chapter 2 was to determine the effect of peripherally disrupted sensory feedback on motor sequence learning. If proprioception were important for motor learning of a continuous task, then disruption of proprioceptive sensation should have deleteriously impacted performance and learning of a continuous sequence. Experiment 1 demonstrated the disruptive nature of whole arm vibration on limb position sense. However, when vibration was applied in Experiment 2, learning of spatiotemporal regularities in the movement pattern occurred regardless of proprioceptive disruption. Thus, it was concluded that rather than being an essential element of feedback-based learning, it should be considered a component of a robust learning system. Other modalities such as

vision and attention likely also contribute and compensate for disrupted proprioceptive feedback.

*Chapter 3. Manual and Oculomotor Performance Develop Contemporaneously But Independently During Continuous Tracking*

To investigate vision as an important component of this robust motor learning system, individuals engaged in a tracking task while their eye movements were monitored. It was expected based on the previous that the eyes might lead the arm in the learning of continuous sequences as evidenced by an interaction of practice and effector. Further, it was hypothesized that oculomotor and manual error scores would display a moderate relationship with multiple regression analysis. Instead, it was found that improved error for both effectors occurred contemporaneously. Also, minimal interdependency between effectors was noted, suggesting that sequence learning by either motor system (visual or manual) is not dependent on the accuracy of the other system. Rather, as in Chapter 2, accurate visual tracking may be a useful component for building and system-wide motor plan for a sequence of movements.

*Chapter 4. Stroke-related Proprioceptive Deficit is Associated With Disrupted Motor Learning*

The aim of the third experiment was to establish whether sensation is critical for motor sequence learning in a chronic stroke population with varying levels of sensory deficit. If the neural structures conveying and processing somatosensory information were important for motor learning, it was expected that damage to those structures would negatively impact acquisition of a new motor skill. As has been previously demonstrated, some individuals maintain the capacity to learn movement sequences following stroke. However, the integrity

of their proprioceptive perception (kinesthesia) was strongly correlated with any sequence-specific improvements they made. These results provide some of the first evidence that central cortical/subcortical processing of proprioceptive information is critical for the encoding of specific movement patterns.

*Chapter 5. Preserved Continuous Motor Sequence Learning in Some Individuals with Cerebellar Pathology*

The cerebellum likely plays an important role in movement-error assessment and motor learning based on sensory information. The primary aim of the final experiment presented in this dissertation was to qualify the effect of cerebellar damage on the use of proprioception to learn a motor sequence. The experimental protocol used in Chapters 2 and 4 allows for a unique examination of cerebellar use of proprioceptive information. The results confirm and extend previous finding. First, some individuals with cerebellar pathology demonstrated a preserved capacity for motor sequence learning but displayed poorly timed movements as previously reported. Importantly, participants in the present study performed the tracking task with the more involved hand, contradicting previous findings of disrupted ipsilesional learning. Individuals that learned tended to have smaller regions of pathology that preserved the cerebellar cortex. Other individuals, with generally much larger areas of infarct encompassing portions of the cerebellar cortex, did not demonstrate sequence-specific learning and appeared to attempt a strategy of movement anticipation. These individuals also demonstrated severe sensory and motor deficits. The results suggest that the area of cerebellar damage may be critical the maintenance of somatosensory feedback-based motor learning.

## *6.2 Limitations*

### *Proprioceptive Disruption*

The literature appears to lack a controlled report on human novel motor sequence learning with disrupted somatosensation that employs a separate retention test. Therefore a population of otherwise healthy adults was chosen to in which to transiently disrupt proprioception. As outlined in Chapter 1, Bock and colleagues (2007) recently confirmed that vibration is an effective means of stimulating primary muscle spindle (Brown et al. 1967; Roll and Vedel 1982; Roll et al. 1989) and cutaneous afferents (Collins et al. 2000; Collins et al. 2005) for the study of motor control. Sensory receptors fire synchronously with the vibration stimulus masking movement-related signaling.(Roll and Vedel 1982) Continuous tracking likely results in significant primary spindle activity during constant limb velocity shifts. For this reason, vibration was chosen to transiently disrupt proprioception

It is possible that vibration did not unrecognizably disrupt proprioception. Therefore, the findings of Chapter 2 may have been bolstered by recruitment of deafferented participants whose proprioception would be completely eliminated. However, this presents a different set of challenges. First, individuals long past deafferentation onset are likely to have developed compensatory strategies.(Cole and Sedgwick 1992; Rothwell et al. 1982) Second, the prevalence of complete deafferentation is low and researchers typically reuse qualifying participants.(Gordon et al. 1995) The present study may not have been feasible using this population.

Other methods of exogenous sensory disruption exist. One is to apply constant, vascular occluding pressure to the arm via a sphygmomanometer. The resulting transient anaesthesia mimics the consequences of sensory neuropathy. However, the unpublished experiences of this author suggest that hypoxic restriction via the method reported by

Ziemann et al.(2001) quickly leads to both sensory and motor disruption. There appears to be no report in the literature that vibration directly impacts efferent nerves, making vibration useful for more strict study of sensory disruption than ischemic nerve block.

Perhaps the most promising technique for sensory disruption study paradigms is the utilization of repetitive transcranial magnetic stimulation (rTMS). rTMS applied under certain parameters temporarily reduces cortical excitability in a directed area.(Pascual-Leone et al. 1999) This technique utilizes and has been demonstrated to disrupt parietal cortex function (Hilgetag et al. 2001) and can be targeted to small regions such as the hand region of S1.(Ishikawa et al. 2007) Unfortunately, TMS cannot be used on subcortical structures.

### *Indexing Proprioception*

Limb-position matching is a consensually valid clinical test for examining proprioceptive deficit. However, clinically it is difficult to express as a numeric measure. For the purposes of this research it was necessary to more consistently quantify kinesthesia. Therefore a previously reported method of proprioceptive indexing (van Deursen et al. 1998) modified for the upper extremity was employed. Lesion analysis was also used to identify disruption of brain regions likely involved with proprioceptive processing.

Other, perhaps more robust measures of proprioceptive health have been reported. Several studies have demonstrated that somatosensory evoked muscle potentials can be modulated through TMS (Ishikawa et al. 2007; Kujirai et al. 1993) One possible method would be to compare these evoked potentials between hemispheres in individuals with unilateral stroke, or between matched groups. The drawback is that this method does not target proprioceptive perceptual regions.

Biodex machines can be used to test error between passive limb placement and active replacement, yielding a precise measure of position matching capacity.(Santos et al. 2007; Sterner et al. 1998) However, this protocol requires memorization of position and utilizes discrete movements. In contrast, the method used in the present work directs the participant to maintain real-time, dynamic position matching, arguably a more ecologically valid challenge.

#### *Confounds of Lesion Location*

It is becoming increasingly clear that sensory and motor cortices are not only internconnected but are highly interdependent. Nudo and colleagues have shown that pure lesions to primate motor cortex leads to behaviors commonly associated with sensory disruption, such as visual checking of grabbing success.(Friel et al. 2005; Nudo et al. 2000) These findings indicate that at the very least, M1 integrates sensory information into motor activity. M1 receives somatosensory input from the thalamus (Asanuma and Mackel 1989; Holsapple et al. 1991) and somatosensory cortex.(Porter and Sakamoto 1988) Motor to sensory projections are less apparent. Dancause et al.(Dancause et al. 2005) reported premotor projections to somatosensory cortex in lesioned animals only. These corticocortical connections were absent in neurologically intact control animals. Others have noted corticospinal neurons in S1 (Sessle and Wiesendanger 1982), though the bulk of motor information passed to the parietal sensory areas may come from corticocerebellar circuitry and processed in the secondary somatosensory cortex.(Blakemore et al. 2000)

Because of this close sensorimotor interaction, damage to one cortical region can result in apparent deficits in the other. Thus, it may be suggested that the current findings reported in Chapters 3 and 4 are confounded by the use of the hemiparetic arm. That is to say

damage to motor pathways may have resulted in aberrant sensory disruption measures or in learning measures that do not accurately reflect skill consolidation. Though this cannot be ruled out, there is reason to believe that data from the present work was not contaminated to a consequential degree by motor pathway damage. Nudo, Friel, and colleagues (Friel et al. 2005; Nudo et al. 2000) reported behaviors consistent with evaluation of the success of a reach and grasp. In contrast to those active motor behaviors, during proprioceptive testing, the involved arm was passive and driven by the experimenter, only the less involved arm was volitionally moved in the matching task. Thus only kinesthesia was necessary and not active motor control. In Chapter 4 proprioceptive integrity was related to sequence-specific motor learning. Thus, sequence learning was compared to passively moved limb position sense which should have minimized any sensorimotor confound in these data.

Second, during skill acquisition a change score was used to index sequence-specific learning relative to general motor performance seen on random epochs. (Boyd and Winstein 2006; Boyd and Winstein 2001) If proprioception was affected by a motor cortical lesion, the effect would be expected in both the random and sequence epoch tracking performance. Improvement over random waveform tracking would still then reflect sequence-specific learning beyond general motor control improvements.

Finally, known cerebrotocerebellar signaling is primarily conducted through the ventral posterior and ventral lateral thalamic nuclei and internal capsule to the premotor and motor cortex. Thus, damage to these regions can produce both sensory deficits as well as sequelae related to cortico-cerebellar interaction. In individuals with thalamic lesions, performance decrements could result from both disrupted sensation as well as disrupted cortico-cerebellar interaction. With more elegant methods of neuroimaging such as diffusion tensor imaging (DTI) it would be possible to roughly quantify the damaged pathways. However, cerebellar

mapping with DTI is still in the descriptive stages.(Salamon et al. 2007) Dissociation would also be possible using a cohort of cerebral cortex-only strokes. However these circumscribed lesions are extremely rare outside induced stroke models in monkeys.(Nudo et al. 2003)

### *6.3 Sequence Learning and Proprioception*

Though an extensive literature in motor learning grows larger by the month, the role of proprioception in motor learning remains under examined. This dissertation and the experiments documented within represent early studies of the role afferent somatic information plays in acquisition and retention of a novel motor skill. It seems appropriate then to place this work in context of what is known about proprioception, motor learning, CNS pathology and the intersection of these variables.

#### *Peripheral Disruption of Proprioception*

Proprioception is important for accurate movement. This has been demonstrated repeatedly in case study (Rothwell et al. 1982) and experiment alike.(Ghez et al. 1990) Proprioception aids in appropriately coordinating sequential movements.(Cordo et al. 1994) Individuals with complete peripheral neuropathies exhibit errors in reaching that suggest the motor control system is not being informed of changes in body dynamics.(Gordon et al. 1995) Vision can temporarily substitute but proprioception is necessary for long-term maintenance of internal body representations.(Ghez et al. 1995) Artificial disruptions of proprioception by vibration result in failure to adapt to novel environments (Bernier et al. 2007; Pipereit et al. 2006) when not overruled by vision.(Bernier et al. 2006; Sober and Sabes 2003) These studies were one-time experimental sessions that did not consider more permanent changes in the capacity to perform.(Schmidt and Lee 1999a)

In the first experiment of chapter 1 and early performance of Experiment 2 we found that disrupting proprioception with vibration interfered with performance, perhaps by masking proprioceptive signals the CNS used to coordinate movement. These effects are in agreement with the previous literature on the use of proprioception to guide movement. However, this ultimately did not prevent participants from learning a specific sequence of movements which may reflect a robust sensorimotor learning system able to capitalize on other sensory and cognitive systems to process and encode representations of the movement pattern. Over the course of a long movement such as a 15s continuous tracking bout, visual and manual systems appear to operate relatively independently of each other (see Chapter 3), One system could therefore provide information regarding a sequence characteristics regardless of the accuracy of the other.

#### *Central Disruption of Proprioceptive Processing*

Primate studies have shed much light on specific neural and molecular substrates of sensorimotor learning. Perhaps the most well developed lines of evidence for sensorimotor interaction in learning come from Asanuma, Pavlides and colleagues.(Iriki et al. 1989; 1991; Pavlides et al. 1993; Sakamoto et al. 1989) Several regions in the parietal cortex are well recognized as receptive and processing areas for sensory information. The same systems allow us to maintain awareness of our bodies in that environment, through somatosensory information. It has been hypothesized that sensory inputs acts to train motor output skills in early practice.(Asanuma and Pavlides 1997) As discussed in the Introduction (Section 1.6) skill acquisition requires somatosensory cortex, probably through paired thalamo-sensoricortical stimulation of motor cortex.(Iriki et al. 1991) If this theory of motor learning

holds, then damage to areas that receive and process sensory information should impact human motor learning as it does in animals.

Other than the characterization of general lesion location, this dissertation work was not able to evaluate CNS physiology or pathology. Nevertheless, the experiment detailed in Chapter 4 is one of the first reported attempts to quantify the impact of disordered proprioceptive sensation on motor learning in humans. Consistent with the posited role of sensory cortical areas “teaching” the motor system a skilled movement, we found that integrity of the proprioceptive processing system, as indexed by a consensually valid clinical test, was strongly related to sequence-specific motor skill acquisition.

Finally, much has been proposed but little concluded regarding the role of the cerebellum in motor learning. Mixed reports of disrupted and maintained motor sequence learning can be found in the literature.(Boyd and Winstein 2004a; Gomez-Beldarrain et al. 1998) Much evidence seems to point to a role in coordination of movement, including the assembly of multiple movement segments in the appropriate time-course to produce skilled behaviors.(Grossberg and Paine 2000; Sakai et al. 2004) The work in Chapter 5, supports the reports preserved sequence learning but impaired temporal execution in individuals.(Boyd and Winstein 2004a) Further, it extends this capacity to the ipsilesional side of the body, previously reported to have impaired sequence learning.

The findings of the study, considered in light of the available evidence suggest an interesting dichotomy regarding the role of proprioception, feedback evaluation and motor learning. In the next section, the present findings are discussed in the context of a widely accepted motor learning model.

#### *6.4 Encoding the Movement Sequence*

Throughout this dissertation, the internal model has been mentioned as the theoretical mechanism by which sensation and motor control are integrated to learn and execute a skill. (Kawato and Gomi 1992; Wolpert et al. 1995) This internal model is purported to account for the internal and external forces such as momentum and friction that must be considered to achieve the movement goal as well as predict the consequences of our plan for movement. The model may also encode a pattern of muscle activity necessary to complete a skill based on initial and desired positions. (Krakauer et al. 1999) The present data reflect more directly on the kinematic internal model by examining the acquisition of a series of movements separate from general motor control.

It must be acknowledged, though, that the literature rarely refers to internal models of movement sequences such as the continuous tracking sequence used throughout this dissertation. This omission occurs despite these behavioral patterns being essential to daily activity. It is unclear if this is a limitation of the concept or a product of the experimental paradigms employed by leading researchers in the field. Nevertheless, this author suggests that evidence exists for representation of movement sequences by internal models.

Krakauer noted that internal models are developed both for the kinematics and kinetics of a discrete reaching task. (Krakauer et al. 1999) What happens when reaching is followed with another movement, such as changing the aperture of the hand to grasp your morning coffee. While this is occurring, the brain predicts the weight of the cup, braces appropriately at the shoulder girdle and plans the appropriate grip force, then begins to bring the cup to your mouth: all in a matter of milliseconds. This sequence of movements is practiced from a young age but occurs in the healthy adult with such fluidity and speed, it is unlikely that each step is a discrete action. Rather, the simple elements are likely chunked

together as we learn. Sakai and colleagues (Sakai et al. 2003) elegantly demonstrated that individuals compose a sequence of movement elements into groups. As we learn, these groups, or chunks, continue to evolve, encompassing more elemental parts that are executed as a group. These chunks are not specific to the movement but rather idiosyncratically determined. If the internal model can represent a discrete reaching movement in a specific direction encountering a specific force environment, should it not also be able to represent the grasp at the end of that reach?

A study by WainScott et al. (WainScott et al. 2005) has addressed this question at least in part. By having participants perform a couplet of random movements in a force field, the authors demonstrated that inverse models of novel dynamics take into account the order of component and upcoming movements. It is possible that many models can be used simultaneously or sequentially for highly skilled motor behaviors. It remains to be seen if a single internal model can represent complex movements such as reaching for a full cup of coffee or pitching a curve ball, calculating necessary motor commands and predicting outcomes. However, the results of the present work are in line with the findings of the importance of central proprioceptive processing for motor learning and thus hint that this may be the case.

#### *Possible Physiological Mechanisms of Sensorimotor Interaction During Learning*

The work detailed in this study is framed by the author's understanding of the internal model as the most current conceptualization of Schmidt's motor schema.(Schmidt 1975; Vercher et al. 2003) In this model, skills are represented by required movement specifications, and expected outcomes, fit to and modified by initial conditions and realized outcomes. The internal model learns to forwardly predict the sensory outcome of a set of

motor commands and inversely, the motor commands for a desired outcome.(Blakemore et al. 2001; Davidson and Wolpert 2005; Kawato 1999; Kawato and Wolpert 1998; Wolpert et al. 1995) With practice, as the skill becomes more automated, less sensory “guidance” is necessary.(Asanuma and Pavlides 1997) Ultimately, with help from the visual system, motor skills can be performed in a prognostic or feedforward manner.(Ghez et al. 1990; Polit and Bizzi 1979; 1978) At least for short, discrete movements the brain can evaluate, change and update the motor plan based on its own prediction of outcome.(Davidson and Wolpert 2005).

Research on internal models for movement have separately invoked the cerebellum and cerebral cortex. The data presented here support the involvement of the CNS as a whole for motor learning as opposed to attributing motor sequence learning to one of these central structures. This author suggests that both the cerebellum and sensorimotor cortex learn movement patterns in part through intention and execution evaluated against sensory feedback including vision, proprioception and knowledge of success. In this hypothesis, sensorimotor cerebral structures are responsible for developing and maintaining representation of desired behaviors in terms of their proprioceptive and visual outcome (or perhaps auditory), including position and velocity of limb segments.(Hwang and Shadmehr 2005; Hwang et al. 2006a; Nasir and Ostry 2006; Sober and Sabes 2003; Thoroughman and Shadmehr 1999) The following paragraphs will outline how this might be possible.

The sensorimotor structures, including subcortical basal ganglia loops, encode a representation of desired actions and component movements. Several studies have reported plastic modification or motor plan learning/disruption in the sensorimotor cortex.(Fisher et al. 2000; Li et al. 2001; Matsuzaka et al. 2007) This is accomplished in part through the potentiation of appropriate motor execution networks by processed sensory feedback.(Asanuma and Pavlides 1997; Hamdy et al. 1998; Iriki et al. 1989; Pavlides et al.

1993) In the absence of accurate and dependable external sensory feedback, internal feedback can be used. Christensen (2007) recently demonstrated that during transient deafferentation and voluntary movements, vPMC activity is correlated with SI activity. This suggests a possible pathway for sensorimotor interaction and learning such as reported in Chapter 2. However, when cortical/subcortical sensory processing structure are disrupted encoding of sequence-specific movement patterns is also disrupted (see Chapter 4).

The critical point here is the integrity of the sensory processing system. Parietal cortex is known to maintain representations of the body.(Wolpert et al. 1998) When these sensory-associated regions are disrupted, by insult (Chapter 4) or by transient disturbance such as TMS (Della-Maggiore et al. 2004) learning is compromised. If these structures remain intact, they are available to create representations, or internal models, of behavior through intracortical interaction even when one or more sources of feedback are undependable (Chapter 2).

This proposition by no means diminishes the role of the cerebellum in this process. Leading researchers in the field of internal models have placed the internal model entirely within the cerebellum.(Imamizu et al. 2000) This is for good reason as the cerebellum is repeatedly demonstrated to be active during learning. However, this author suggests that the cerebellum plays a specific role in the development of predictive control that fits the research. Specifically, the role of the cerebellum in motor learning and execution may be primarily to learn predictive coupling of movement segments for coordinated and fluid movement. This has been proposed previously by Grossberg and Paine.(2000) (However, it may also support error-feedback learning of individual movements themselves as well. The performance of the CB-N group in Chapter 5 suggests this but it is unclear if this results from disordered movement or a true failure to learn the velocity pattern.)

This conceptualization of the role of the cerebellum as primarily a coordinator would account for the observed predictive capacity of the cerebellum.(Blakemore et al. 2001; Nowak et al. 2005) It would also account for the preserved pattern but disrupted temporal execution reported, as the cerebellum would be necessary for learning to predict and help execute the correct timing and coordination of serial actions into a continuous movement pattern.{Boyd, 2004}(also see Chapter 4) It may also explain cerebellar activation in novel environment adaptation, again as the cerebellum learned to predict the correct timing and order of serial movement segments to produce a successful movement.

Proprioception would serve as an important template for comparison of the predicted behavior against the realized behavior in both the cerebellum and sensorimotor cortex. Proprioception is the likely language for encoding limb state and EMG closely matches how limb state is encoded by proprioceptors.(Hwang et al. 2006a; Prochazka and Gorassini 1998) During skill practice, this process would either reinforce or discourage the plan that was used through LTP of involved motor cortical cells (Imamizu et al. 2003; Imamizu et al. 2000) and Purkinje cells of the cerebellum.(Ito 1989) In this conceptualization the actual outcome, conveyed via the afferent somatosensory system, is compared to the desired outcome and the motor commands, perhaps in the cerebellum.(Fujita 1982; Kawato and Gomi 1992)

Motor skills then would also require the interaction of these separate structures to produce a highly skilled and accurate movement with information flowing freely between these structures regarding plans, outcomes and adjustments. Fortunately, the literature is replete with reports of these interactions. For example, Holsapple et al. (Holsapple et al. 1991) demonstrated that the ventrolateral nucleus of the thalamus in primates receive signals from both cerebellum and basal ganglia and then project to M1. In another example of cortio-cerebellar interaction, Brown and colleagues (Brown and Bower 2002) have reported

that SI, strongly concerned with proprioception (Rausch, 1998) influences complex spike activity in the cerebellum.

#### *6.4 Clinical Implications*

A comprehensive understanding sensorimotor interaction during both performance and learning is critical for optimization and restoration of skilled behavior. The knowledge is applicable in both rehabilitative and healthy exercise settings. For example, proprioceptive neuromuscular facilitation (PNF) is a training methodology that emphasizes the stimulation of proprioceptors via stretch and resistance to maximize movement control.(Knott and Voss, 1968) The spiral and diagonal patterns of movement employ stretch and resistance to train the participants to more effectively functional movements and increase joint range.(Decicco and Fisher 2005) These patterns are ultimately used in the performance of functional activities such as toileting or climbing stairs (Knott and Voss 1968). The principles of PNF are considered applicable for individuals with pathology as well as those seeking improved motor performance.(Decicco and Fisher 2005)

However, the data on proprioceptive disruption of healthy individuals presented here do not wholly support PNF principles. For neurologically intact individuals, these patterns of stretch assisted movement may improve range or strength but it appears that the proprioceptors are not absolutely necessary for learning movements. In contrast, there may be some validity to the suggestion that PNF principles help those with central lesions to “develop or redevelop the responses of the neuromuscular mechanism” via proprioceptive stimulation.(Knott and Voss 1968) The present data suggest that proprioceptive deficit is a predictor of motor learning capacity. Though these data cannot comment on the efficacy of any particular therapeutic intervention, augmentation of existing proprioceptive feedback or

compensation with other sensory modalities (i.e. vision, audition, discriminative cutaneous sensation, vestibulation) that are concurrent with PNF treatment may be helpful during rehabilitation.

Davies found perceptual deficits and stroke sequelae that “cannot be observed” to be so important she addressed therapeutic response to the problem in her first chapter of her monograph on rehabilitation.(Davies 2000) A similar sensory-oriented approach has been promulgated by Margaret Rood.(O'Sullivan 2000) Considering the findings of the present work, this emphasis may be warranted. As shown in Chapter 4, proprioceptive deficit is related to motor learning capacity. Intervention strategies that enhance sensory feedback may improve motor performance.(Priplata et al. 2003; Priplata et al. 2006; Wells et al. 2005) In related studies, providing a more complete sensory experience during practice improves motor performance. Wu and colleagues (2000) observed faster, more efficient movements in stroke patients and control subjects who practiced reaching for real objects as opposed reaching for a location. In an ingenious study the same group (Wu et al. 1998), demonstrated that providing for a tangible consequence to movement greatly improved movement quality. Using a one-hand chopping device, stroke patients did markedly better, when chopping a mushroom than when chopping nothing.

As with most therapeutic interventions an important caveat must be considered. In this case, conscious attention to those sensory experiences, including proprioception can be detrimental. Fasoli and colleagues (2002) observed survivors of stroke and healthy controls produced better quality reaching movement when instructed to direct their focus externally on the task as opposed to internally. Similar findings have been documented in studies of athletic performance in healthy young adults.(Wulf et al. 2000) The critical difference between these findings and those in the rehabilitation literature appears to be directed

attention. Though sensory input may be critical to learning, paying attention to perception can negatively impact learning and performance.

### *6.5 Future Directions*

The long-term goal of this project is to characterize the contribution of intrinsic somatosensory feedback to motor learning both in healthy and pathologic populations. The presented work has established the foundation for more elegant exploration of sensorimotor interaction. Several candidate areas of investigation based on the literature present themselves including, but by no means limited to task complexity, effector interaction and sensory training or assistance.

### *Several Sources of Feedback*

The experimental protocol used in these studies was designed to limit visual and, in the case of Chapter 2, proprioceptive feedback regarding tracking performance. Based on the findings reported in Chapter 2, it is conceivable if not likely that participants were using other sources of feedback to learn the movement pattern. One likely source of information is simple attention to the target. Simply watching a repeated pattern can result in some degree of learning.(Bird et al. 2005; Kelly et al. 2003) Construction of sequence representation occurs in the parietal cortex,(Frey and Gerry 2006) which is perhaps why neurologically intact individuals with disrupted proprioception were able to learn the sequence when those with central lesions could not. However, by conducting the task under dual task conditions such as mental mathematical calculations as well as disrupted proprioception the contribution of attention could be evaluated. Though this has been done in probabilistic (Shanks et al.

2005) and repeated sequence tasks (Cohen et al. 1990) it does not appear to have been performed in a continuous sequence tracking paradigm.

### *Movement Complexity*

Continuous tracking was employed in this study partly to increase the kinematic complexity of the skill to be learned. However, it is unlikely that upper extremity tracking approaches the complexity of some real world skills such as skiing.(Wulf et al. 1999; Wulf and Toole 1999) Similar tasks such as whole body sequence tracking have been employed previously.(Shea et al. 2001) Whole body balance tasks necessitate control of more degrees of freedom; one criterion in the evaluation of movement complexity.(Wulf and Shea 2002) To evaluate proprioceptive dependence on increasingly complex skills, the above mentioned experimental paradigms could be performed under conditions of vibration. Currently marketed vibration platform trainers make this feasible.

### *Effector Interaction*

The internal model allows for an advance prediction of the outcome of the motor plan and therefore the ability to base other behaviors on that expected outcome. One such closely studied paradigm involves visual-manual coordination.(Carlton 1981; Desmurget et al. 1998; Keele and Posner 1968; Vaziri et al. 2006) Skilled behaviors often require close coordination between manual and oculomotor movements. As has been demonstrated previously, advance predictions aid in the production of coordinated effector movements such as ocular and manual movements.(Steinbach and Held 1968) The conclusion that the eyes lead the arm during discrete predictable movements is further supported by documentation of anticipatory

saccadic behavior during serial movements where each successive manual movement is known in advance and can be pre-planned.(Marcus et al. 2006)

Development of the inverse model for a skilled movement that allows for coordinated activity of other systems may depend substantially on proprioception.(Vercher et al. 1996; Vercher et al. 2003) It is presently unknown if these coordinated patterns of movement are disrupted following stroke-related proprioceptive disruption. If oculomanual coordination is disrupted following stroke, an understanding of the functional relevance of this disruption could assist rehabilitation professionals in providing appropriate remediation or compensation strategies.

## *6.6 Conclusions*

The work presented in this dissertation indicates a more complex picture of the use of proprioceptive feedback for motor learning than simply whether it is necessary or not. There is little doubt that proprioception is critical for informing the CNS of the current state of the body for planning a movement (Polit and Bizzi 1979) or that proprioception helps develop and maintain representations of bodily and environmental dynamics.(Gordon et al. 1995; Pipereit et al. 2006) However, the present findings suggest that when limb position sense is peripherally disrupted other sources of feedback can be utilized or substituted for motor sequence learning. Clinically, this is important for the rehabilitation of those with peripheral sensory neuropathy, such as diabetic neuropathy or Guillain-Barre syndrome. It appears that new skills can be learned despite disrupted afferent information. In contrast, when perceptual areas of the cortex/subcortex are damaged, proprioceptive sensation is related to learning of the repeated, integral components of the movement pattern but not necessarily general non-sequence-specific elements of the task. It also appears that when the cerebellar cortex is

mostly intact, feedback and learning through primarily proprioceptive registration of movement patterns is maintained. This may result from the role of these central structures in integrating sensory and motor experiences into the motor plan for skills through mechanisms such as long term potentiation and depression.

Clinically, these findings suggest that rehabilitation professionals should consider the health of central nervous system regions concerned with the processing of proprioceptive information. Mild to moderate, neuropathic conditions affecting the peripheral sensory structures such as occurs with chronic diabetes may not impede rehabilitative care. However, large scale injury to central, sensory processing structures such as parietal cortex, thalamus, and the cerebellum can have potentially significant bearing on the acquisition of motor skills. Learning of specific patterns of movement, a common goal of therapies, appear to be impeded by damage to these and related regions. Future studies such as those outlined previously will be necessary for elucidating why this peripheral-central dichotomy exists, if it is clinically relevant, and how rehabilitative potential can be maximized when proprioceptive deficits result from CNS lesions.

## References

- Allen GI, Gilbert PF, Marini R, Schultz W, and Yin TC. Integration of cerebral and peripheral inputs by interpositus neurons in monkey. *Exp Brain Res* 27: 81-99, 1977.
- Allen GI, Gilbert PF, and Yin TC. Convergence of cerebral inputs onto dentate neurons in monkey. *Exp Brain Res* 32: 151-170, 1978.
- Aron A, and Aron EN. Correlation. In: *Statistics for psychology*. Upper Saddle River, NJ: Simon & Schuster, 1999, p. 64-100.
- Asanuma H, and Mackel R. Direct and indirect sensory input pathways to the motor cortex; its structure and function in relation to learning of motor skills. *Jpn J Physiol* 39: 1-19, 1989.
- Asanuma H, and Pavlides C. Neurobiological basis of motor learning in mammals. *NeuroReport* 8: i-vi, 1997.
- Association AH. Heart and Stroke Statistical Update—2006 Update. Dallas, Tex: : American Heart Association, 2006.
- Bahill AT, and McDonald JD. Model emulates human smooth pursuit system producing zero-latency target tracking. *Biol Cybern* 48: 213-222, 1983.
- Bares M, Lungu O, Liu T, Waechter T, Gomez CM, and Ashe J. Impaired predictive motor timing in patients with cerebellar disorders. *Exp Brain Res* 180: 355-365, 2007.
- Barnes GR, and Schmid AM. Sequence learning in human ocular smooth pursuit. *Exp Brain Res* 144: 322-335, 2002.
- Beppu H, Suda M, and Tanaka R. Analysis of cerebellar motor disorders by visually guided elbow tracking movement. *Brain* 107 ( Pt 3): 787-809, 1984.
- Bernier PM, Chua R, Bard C, and Franks IM. Updating of an internal model without proprioception: a deafferentation study. *Neuroreport* 17: 1421-1425, 2006.

- Bernier PM, Chua R, Inglis JT, and Franks IM. Sensorimotor adaptation in response to proprioceptive bias. *Exp Brain Res* 177: 147-156, 2007.
- Bevan L, Cordo P, Carlton L, and Carlton M. Proprioceptive coordination of movement sequences: discrimination of joint angle versus angular distance. *J Neurophysiol* 71: 1862-1872, 1994.
- Bird G, Osman M, Saggerson A, and Heyes C. Sequence learning by action, observation and action observation. *Br J Psychol* 96: 371-388, 2005.
- Blakemore S-J, Frith CD, and Wolpert DM. The cerebellum is involved in predicting the sensory consequences of action. *NeuroReport* 12: 1879-1884, 2001.
- Blakemore S-J, Wolpert DM, and Frith C. Why can't you tickle yourself? *NeuroReport* 11: 11-16, 2000.
- Bloedel JR. Cerebellar afferent systems: a review. *Prog Neurobiol* 2: 3-68, 1973.
- Bock O, and Eckmiller R. Goal-directed arm movements in absence of visual guidance: evidence for amplitude rather than position control. *Exp Brain Res* 62: 451-458, 1986.
- Bock O, Pipereit K, and Mierau A. A method to reversibly degrade proprioceptive feedback in research on human motor control. *J Neurosci Methods* 160: 246-250, 2007.
- Bornschlegl M, and Asanuma H. Importance of the projection from the sensory to the motor cortex for recovery of motor function following partial thalamic lesion in the monkey. *Brain Res* 437: 121-130, 1987.
- Boussaoud D, di Pellegrino G, and Wise SP. Frontal lobe mechanisms subserving vision-for-action versus vision-for-perception. *Behav Brain Res* 72: 1-15, 1995.

- Boyd L, and Winstein C. Explicit information interferes with implicit motor learning of both continuous and discrete movement tasks after stroke. *J Neurol Phys Ther* 30: 46-57; discussion 58-49, 2006.
- Boyd LA, Vidoni ED, and Siengsukon CF. Multidimensional Motor Sequence Learning Is Impaired in Older But Not Younger or Middle-Aged Adults. *Phys Ther* in press.
- Boyd LA, and Winstein CJ. Cerebellar Stroke Impairs Temporal but Not Spatial Accuracy during Implicit Motor Learning. *Neurorehabil Neural Rep* 18: 134-143, 2004a.
- Boyd LA, and Winstein CJ. Impact of Explicit Information on Implicit Motor-Sequence Learning Following Middle Cerebral Artery Stroke. *Phys Ther* 83: 976-989, 2003.
- Boyd LA, and Winstein CJ. Implicit motor-sequence learning in humans following unilateral stroke: the impact of practice and explicit knowledge. *Neurosci Lett* 298: 65-69, 2001.
- Boyd LA, and Winstein CJ. Providing explicit information disrupts implicit motor learning after basal ganglia stroke. *Learn Mem* 11: 388-396, 2004b.
- Broeks JG, Lankhorst GJ, Rumping K, and Prevo AJ. The long-term outcome of arm function after stroke: results of a follow-up study. *Disabil Rehabil* 21: 357-364, 1999.
- Brown IE, and Bower JM. The influence of somatosensory cortex on climbing fiber responses in the lateral hemispheres of the rat cerebellum after peripheral tactile stimulation. *J Neurosci* 22: 6819-6829, 2002.
- Brown MC, Engberg I, and Matthews PB. The relative sensitivity to vibration of muscle receptors of the cat. *J Physiol* 192: 773-800, 1967.
- Burke MR, and Barnes GR. Sequence learning in two-dimensional smooth pursuit eye movements in humans. *J Vis* 7: 5, 2007.

- Byl NN, Merzenich MM, and Jenkins WM. A primate genesis model of focal dystonia and repetitive strain injury: I. Learning-induced dedifferentiation of the representation of the hand in the primary somatosensory cortex in adult monkeys. *Neurology* 47: 508-520, 1996.
- Capaday C, and Cooke JD. The effects of muscle vibration on the attainment of intended final position during voluntary human arm movements. *Exp Brain Res* 42: 228-230, 1981.
- Capaday C, and Cooke JD. Vibration-induced changes in movement-related EMG activity in humans. *Exp Brain Res* 52: 139-146, 1983.
- Carey LM. Somatosensory loss after stroke. *Crit Rev Phys Rehabil Med* 7: 51-91, 1995.
- Carlton LG. Visual information: The control of aiming movements. *Q J Experimental Psychology A* 33: 87-93, 1981.
- Cham J. #937. phdcomics.com, 2007.
- Christensen MS, Lundbye-Jensen J, Geertsen SS, Petersen TH, Paulson OB, and Nielsen JB. Premotor cortex modulates somatosensory cortex during voluntary movements without proprioceptive feedback. *Nat Neurosci* 10: 417-419, 2007.
- Clower DM, West RA, Lynch JC, and Strick PL. The inferior parietal lobule is the target of output from the superior colliculus, hippocampus, and cerebellum. *J Neurosci* 21: 6283-6291, 2001.
- Cohen A, Ivry RI, and Keele SW. Attention and structure in sequence learning. *J Exp Psychol Learn Mem Cogn* 16: 17-30, 1990.
- Cohen J, Cohen P, West SG, and Aiken LS. *Applied multiple regression/correlation analysis for the behavioral sciences*. Hillsdale, NJ: Lawrence Erlbaum Assoc., 2003.
- Cole JD, and Sedgwick EM. The perceptions of force and of movement in a man without large myelinated sensory afferents below the neck. *J Physiol* 449: 503-515, 1992.

- Collins DF, Refshauge KM, and Gandevia SC. Sensory integration in the perception of movements at the human metacarpophalangeal joint. *J Physiol* 529 Pt 2: 505-515, 2000.
- Collins DF, Refshauge KM, Todd G, and Gandevia SC. Cutaneous receptors contribute to kinesthesia at the index finger, elbow, and knee. *J Neurophysiol* 94: 1699-1706, 2005.
- Cordo P, Bevan L, Gurfinkel V, Carlton L, Carlton M, and Kerr G. Proprioceptive coordination of discrete movement sequences: mechanism and generality. *Can J Physiol Pharmacol* 73: 305-315, 1995a.
- Cordo P, Carlton L, Bevan L, Carlton M, and Kerr GK. Proprioceptive coordination of movement sequences: role of velocity and position information. *J Neurophysiol* 71: 1848-1861, 1994.
- Cordo P, Gurfinkel VS, Bevan L, and Kerr GK. Proprioceptive consequences of tendon vibration during movement. *J Neurophysiol* 74: 1675-1688, 1995b.
- Cordo PJ, and Gurfinkel VS. Motor coordination can be fully understood only by studying complex movements. *Prog Brain Res* 143: 29-38, 2004.
- Costanzo RM, and Gardner EP. Multiple-joint neurons in somatosensory cortex of awake monkeys. *Brain Res* 214: 321-333, 1981.
- Cox R. AFNI: software for analysis and visualization of functional magnetic resonance neuroimages. *Comput Biomed Res* 29: 162-173, 1996.
- Dancause N, Barbay S, Frost SB, Plautz EJ, Chen D, Zoubina EV, Stowe AM, and Nudo RJ. Extensive cortical rewiring after brain injury. *J Neurosci* 25: 10167-10179, 2005.

- Darian-Smith. Chapter 17. The sense of touch: performance and peripheral neural processes. In: *The Nervous System*, edited by Brookhart JM, and Mountcastle VB. Bethesda, MD: American Physiological Society, 1984, p. 739-788.
- Davidson PR, and Wolpert DM. Widespread access to predictive models in the motor system: a short review. *J Neural Eng* 2: S313-319, 2005.
- Davies PM. Problems that cannot be seen directly. In: *Steps to Follow: the comprehensive treatment of patients with hemiplegia*. Berlin: Springer-Verlag, 2000, p. 1-32.
- Day BL, and Marsden CD. Two strategies for learning a visually guided motor task. *Percept Mot Skills* 55: 1003-1016, 1982.
- Decicco PV, and Fisher MM. The effects of proprioceptive neuromuscular facilitation stretching on shoulder range of motion in overhand athletes. *J Sports Med Phys Fitness* 45: 183-187, 2005.
- Della-Maggiore V, Malfait N, Ostry DJ, and Paus T. Stimulation of the posterior parietal cortex interferes with arm trajectory adjustments during the learning of new dynamics. *J Neurosci* 24: 9971-9976, 2004.
- Derouesne C, Mas JL, Bolgert F, and Castaigne P. Pure sensory stroke caused by a small cortical infarct in the middle cerebral artery territory. *Stroke* 15: 660-662, 1984.
- Desmurget M, and Grafton S. Forward modeling allows feedback control for fast reaching movements. *Trends Cogn Sci* 4: 423-431, 2000.
- Desmurget M, Pelisson D, Rossetti Y, and Prablanc C. From eye to hand: planning goal-directed movements. *Neurosci Biobehav Rev* 22: 761-788, 1998.
- Diedrichsen J, Criscimagna-Hemminger SE, and Shadmehr R. Dissociating timing and coordination as functions of the cerebellum. *J Neurosci* 27: 6291-6301, 2007.

- Doyon J, Song AW, Karni A, Lalonde F, Adams MM, and Ungerleider LG. Experience-dependent changes in cerebellar contributions to motor sequence learning. *Proc Natl Acad Sci U S A* 99: 1017-1022, 2002.
- Exner C, Weniger G, and Irle E. Cerebellar lesions in the PICA but not SCA territory impair cognition. *Neurology* 63: 2132-2135, 2004.
- Fasoli SE, Trombly CA, Tickle-Degnen L, and Verfaellie MH. Effect of instructions on functional reach in persons with and without cerebrovascular accident. *Am J Occup Ther* 56: 380-390, 2002.
- Fisher BE, Boyd L, and Winstein CJ. Contralateral cerebellar damage impairs imperative planning but not updating of aimed arm movements in humans. *Exp Brain Res* 174: 453-466, 2006.
- Fisher BE, Winstein CJ, and Velicki MR. Deficits in compensatory trajectory adjustments after unilateral sensorimotor stroke. *Exp Brain Res* 132: 328-344, 2000.
- Fontana TL, Richardson CA, and Stanton WR. The effect of weight-bearing exercise with low frequency, whole body vibration on lumbosacral proprioception: a pilot study on normal subjects. *Aust J Physiother* 51: 259-263, 2005.
- Forwell LA, and Carnahan H. Proprioception during manual aiming in individuals with shoulder instability and controls. *J Orthop Sports Phys Ther* 23: 111-119, 1996.
- Frey SH, and Gerry VE. Modulation of neural activity during observational learning of actions and their sequential orders. *J Neurosci* 26: 13194-13201, 2006.
- Friel KM, Barbay S, Frost SB, Plautz EJ, Hutchinson DM, Stowe AM, Dancause N, Zoubina EV, Quaney BM, and Nudo RJ. Dissociation of sensorimotor deficits after rostral versus caudal lesions in the primary motor cortex hand representation. *J Neurophysiol* 94: 1312-1324, 2005.

- Fugl-Meyer AR, Jaasko L, Leyman I, Olsson S, and Steglind S. The post-stroke hemiplegic patient. 1. a method for evaluation of physical performance. *Scand J Rehabil Med* 7: 13-31, 1975.
- Fujita M. Adaptive filter model of the cerebellum. *Biol Cybern* 45: 195-206, 1982.
- Gao JH, Parsons LM, Bower JM, Xiong J, Li J, and Fox PT. Cerebellum implicated in sensory acquisition and discrimination rather than motor control. *Science* 272: 545-547, 1996.
- Gardner EP, and Costanzo RM. Properties of kinesthetic neurons in somatosensory cortex of awake monkeys. *Brain Res* 214: 301-319, 1981.
- Gardner EP, and Kandel ER. Chapter 23. Touch. In: *Principles of Neural Science*, edited by Kandel ER, Schwartz JH, and Jessell TM. New York: McGraw-Hill, 2000, p. 451-471.
- Gardner EP, and Thach WT. Chapter 42. The Cerebellum. In: *Principles of Neural Science*, edited by Kandel ER, Schwartz JH, and Jessell TM. New York: McGraw-Hill, 2000, p. 451-471.
- Ghez C, Gordon J, and Ghilardi MF. Impairments of Reaching Movements in Patients Without Proprioception. II. Effects of Visual Information on Accuracy. *J Neurophysiol* 73: 361-372, 1995.
- Ghez C, Gordon J, Ghilardi MF, Christakos CN, and Cooper SE. Roles of Proprioceptive Input in the Programming of Arm Trajectories. *Cold Spr Har Symp Quant Biol* 55: 837-847, 1990.
- Gomez-Beldarrain M, Garcia-Monco JC, Rubio B, and Pascual-Leone A. Effect of focal cerebellar lesions on procedural learning in the serial reaction time task. *Exp Brain Res* 120: 25-30, 1998.

- Goodwin GM, McCloskey DI, and Matthews PBC. The Contribution of Muscle Afferents to Kinaesthesia Shown By Vibration Induced Illusions of Movement and By the Effects of Paralyzing Joint Afferents. *Brain* 95: 705-748, 1972.
- Gooley K, Bradfield O, Talbot J, Morgan DL, and Proske U. Effects of body orientation, load and vibration on sensing position and movement at the human elbow joint. *Exp Brain Res* 133: 340-348, 2000.
- Gordon J, Ghilardi MF, and Ghez C. Impairments of Reaching Movements in Patients Without Proprioception. I. Spatial Errors. *J Neurophysiol* 73: 347-360, 1995.
- Groothuis DR, Duncan GW, and Fisher CM. The human thalamocortical sensory path in the internal capsule: evidence from a small capsular hemorrhage causing a pure sensory stroke. *Ann Neurol* 2: 328-331, 1977.
- Grossberg S, and Paine RW. A neural model of cortico-cerebellar interactions during attentive imitation and predictive learning of sequential handwriting movements. *Neural Netw* 13: 999-1046, 2000.
- Halsband U, Matsuzaka Y, and Tanji J. Neuronal activity in the primate supplementary, pre-supplementary and premotor cortex during externally and internally instructed sequential movements. *Neurosci Res* 20: 149-155, 1994.
- Hamdy S, Rothwell JC, Aziz Q, Singh KD, and Thompson DG. Long-term reorganization of human motor cortex driven by short-term sensory stimulation. *Nature neuroscience* 1: 64-68, 1998.
- Harrington DL, Lee RR, Boyd LA, Rapsak SZ, and Knight RT. Does the representation of time depend on the cerebellum? Effect of cerebellar stroke. *Brain* 127: 561-574, 2004.

- Hatada Y, Rossetti Y, and Miall RC. Long-lasting aftereffect of a single prism adaptation: shifts in vision and proprioception are independent. *Exp Brain Res* 173: 415-424, 2006.
- Helsen WF, Elliot D, Starkes JL, and Ricker KL. Coupling of eye, finger, elbow and shoulder movements during manual aiming. *J Mot Behav* 32: 241-248, 2000.
- Helsen WF, Tremblay L, Van den Berg M, and Elliot D. The Role of oculomotor information in the learning of sequential aiming movements. *J Mot Behav* 36: 82-90, 2004.
- Hilgetag CC, Theoret H, and Pascual-Leone A. Enhanced visual spatial attention ipsilateral to rTMS-induced 'virtual lesions' of human parietal cortex. *Nat Neurosci* 4: 953-957, 2001.
- Hirata C, and Yoshida S. Visual dominance in amending the directional parameter of feedforward control. *J Mot Behav* 32: 17-25, 2000.
- Hocherman S, and Levy H. The role of feedback in manual tracking of visual targets. *Percept Mot Skills* 90: 1235-1248, 2000.
- Hogan N, Bizzi E, Mussa-Ivaldi FA, and Flash T. Controlling multijoint motor behavior. *Exerc Sport Sci Rev* 15: 153-190, 1987.
- Holsapple JW, Preston JB, and Strick PL. The origin of thalamic inputs to the "hand" representation in the primary motor cortex. *J Neurosci* 11: 2644-2654, 1991.
- Howard JH, Jr., Mutter SA, and Howard DV. Serial pattern learning by event observation. *J Exp Psychol Learn Mem Cogn* 18: 1029-1039, 1992.
- Hwang EJ, and Shadmehr R. Internal models of limb dynamics and the encoding of limb state. *J Neural Eng* 2: S266-278, 2005.
- Hwang EJ, Smith MA, and Shadmehr R. Adaptation and generalization in acceleration-dependent force fields. *Exp Brain Res* 169: 496-506, 2006a.

- Hwang EJ, Smith MA, and Shadmehr R. Dissociable effects of the implicit and explicit memory systems on learning control of reaching. *Exp Brain Res* 2006b.
- Imamizu H, Kuroda T, Miyauchi S, Yoshioka T, and Kawato M. Modular organization of internal models of tools in the human cerebellum. *Proc Natl Acad Sci U S A* 100: 5461-5466, 2003.
- Imamizu H, Miyauchi S, Tamada T, Sasaki Y, Takino R, Putz B, Yoshioka T, and Kawato M. Human cerebellar activity reflecting an acquired internal model of a new tool. *Nature* 403: 192-195, 2000.
- Inglis JT, and Frank JS. The effect of agonist/antagonist muscle vibration on human position sense. *Exp Brain Res* 81: 573-580, 1990.
- Iriki A, Pavlides C, Keller A, and Asanuma H. Long-Term Potentiation in the Motor Cortex. *Science* 245: 1385 -1387, 1989.
- Iriki A, Pavlides C, Keller A, and Asanuma H. Long-term potentiation of thalamic input to the motor cortex induced by coactivation of thalamo-cortical and corticocortical afferents. *J Neurophysiol* 65: 1435-1441, 1991.
- Ishikawa S, Matsunaga K, Nakanishi R, Kawahira K, Murayama N, Tsuji S, Huang YZ, and Rothwell JC. Effect of theta burst stimulation over the human sensorimotor cortex on motor and somatosensory evoked potentials. *Clin Neurophysiol* 118: 1033-1043, 2007.
- Ito M. Bases and implications of learning in the cerebellum--adaptive control and internal model mechanism. *Prog Brain Res* 148: 95-109, 2005.
- Ito M. Long-term depression. *Annu Rev Neurosci* 12: 85-102, 1989.
- Ito M. Mechanisms of motor learning in the cerebellum. *Brain Res* 886: 237-245, 2000.

- Ivry RB, Keele SW, and Diener HC. Dissociation of the lateral and medial cerebellum in movement timing and movement execution. *Exp Brain Res* 73: 167-180, 1988.
- Jenkins IH, Brooks DJ, Nixon PD, Frackowiak RS, and Passingham RE. Motor sequence learning: a study with positron emission tomography. *J Neurosci* 14: 3775-3790, 1994.
- Jette DU, Bacon K, Batty C, Carlson M, Ferland A, Hemingway RD, Hill JC, Ogilvie L, and Volk D. Evidence-based practice: beliefs, attitudes, knowledge, and behaviors of physical therapists. *Phys Ther* 83: 786-805, 2003.
- Johansson RS, Hger C, and Backstrom L. Somatosensory control of precision grip during unpredictable pulling loads. III. Impairments during digital anesthesia. *Exp Brain Res* 89: 204-213, 1992.
- Jueptner M, Ottinger S, Fellows SJ, Adamschewski J, Flerich L, Muller SP, Diener HC, Thilman AF, and Weiller C. The relevance of sensory input for the cerebellar control of movements. *NeuroImage* 5: 41-48, 1997.
- Jueptner M, and Weiller C. A review of differences between basal ganglia and cerebellar control of movements as revealed by functional imaging studies. *Brain* 121 ( Pt 8): 1437-1449, 1998.
- Kaneko T, Cairia MA, and Asanuma H. Information Processing Within the Motor Cortex II. Intracortical Connections Between Neurons Receiving Somatosensory Cortical Input and Motor Output Neurons of the Cortex. *J Comp Neurol* 345: 172-184, 1994.
- Kao HS. Effects of intermittency of feedback on a compensatory tracking task. *Percept Mot Skills* 43: 1339-1345, 1976.
- Kawato M. Internal models for motor control and trajectory planning. *Curr Opin Neurobiol* 9: 718-727, 1999.

- Kawato M, and Gomi H. A computational model of four regions of the cerebellum based on feedback-error learning. *Biol Cybern* 68: 95-103, 1992.
- Kawato M, and Wolpert D. Internal models for motor control. *Novartis Found Symp* 218: 291-304; discussion 304-297, 1998.
- Keele SW, and Posner MI. Processing of visual feedback in rapid movements. *J Exp Psychol* 77: 155-158, 1968.
- Kelly SW, Burton AM, Riedel B, and Lynch E. Sequence learning by action and observation: evidence for separate mechanisms. *Br J Psychol* 94: 355-372, 2003.
- Ketcham CJ, Dounskaia NV, and Stelmach GE. The role of vision in the control of continuous multijoint movements. *J Mot Behav* 38: 29-44, 2006.
- Kitazawa S, Kimura T, and Yin PB. Cerebellar complex spikes encode both destinations and errors in arm movements. *Nature* 392: 494-497, 1998.
- Knott M, and Voss DE. *Proprioceptive neuromuscular facilitation patterns and techniques*. New York: Harper & Row, 1968.
- Koo TK, Mak AF, Hung L, and Dewald JP. Joint position dependence of weakness during maximum isometric voluntary contractions in subjects with hemiparesis. *Arch Phys Med Rehabil* 84: 1380-1386, 2003.
- Kowler E, Martins AJ, and Pavel M. The effect of expectations on slow oculomotor control--IV. Anticipatory smooth eye movements depend on prior target motions. *Vision Res* 24: 197-210, 1984.
- Kowler E, and Steinman RM. The effect of expectations on slow oculomotor control-III. Guessing unpredictable target displacements. *Vision Res* 21: 191-203, 1981.
- Kowler E, and Steinman RM. The effect of expectations on slow oculomotor control. I. Periodic target steps. *Vision Res* 19: 619-632, 1979a.

- Kowler E, and Steinman RM. The effect of expectations on slow oculomotor control. II. Single target displacements. *Vision Res* 19: 633-646, 1979b.
- Krakauer J, and Ghez C. Chapter 38. Voluntary Movement. In: *Principles of Neural Science*, edited by Kandel ER, Schwartz JH, and Jessell TM. New York: McGraw-Hill, 2000, p. 756-781.
- Krakauer JW, Ghilardi MF, and Ghez C. Independent learning of internal models for kinematic and dynamic control of reaching. *Nat Neurosci* 2: 1026-1031, 1999.
- Krebs HI, Aisen ML, Volpe BT, and Hogan N. Quantization of continuous arm movements in humans with brain injury. *Proc Natl Acad Sci U S A* 96: 4645-4649, 1999.
- Kujirai T, Sato M, Rothwell JC, and Cohen LG. The effect of transcranial magnetic stimulation on median nerve somatosensory evoked potentials. *Electroencephalogr Clin Neurophysiol* 89: 227-234, 1993.
- Lang CE, and Bastian AJ. Cerebellar damage impairs automaticity of a recently practiced movement. *J Neurophysiol* 87: 1336-1347, 2002.
- Lateiner JE, and Sainburg RL. Differential contributions of vision and proprioception to movement accuracy. *Exp Brain Res* 151: 446-454, 2003.
- Lazzari S, Vercher JL, and Buizza A. Manuo-ocular coordination in target tracking. I. A model simulating human performance. *Biol Cybern* 77: 257-266, 1997.
- Li CS, Padoa-Schioppa C, and Bizzi E. Neuronal correlates of motor performance and motor learning in the primary motor cortex of monkeys adapting to an external force field. *Neuron* 30: 593-607, 2001.
- Liu Y, Pu Y, Gao JH, Parsons LM, Xiong J, Liotti M, Bower JM, and Fo PT. The human red nucleus and lateral cerebellum in supporting roles for sensory information processing. *Hum Brain Map* 10: 147-159, 2000.

- Lundy-Eckman L. Basal Ganglia, Cerebellum and Movement. In: *Neuroscience: Fundamentals for Rehabilitation*. Philadelphia, PA: W.B. Saunders Co., 2002, p. 219-250.
- Mackrout I, and Proteau L. Specificity of practice results from differences in movement planning strategies. *Exp Brain Res* 2007.
- Malchaire J, Rodriguez Diaz LS, Piette A, Goncalves Amaral F, and de Schaetzen D. Neurological and functional effects of short-term exposure to hand-arm vibration. *Int Arch Occup Environ Health* 71: 270-276, 1998.
- Marcus DJ, Karatekin C, and Markiewicz S. Oculomotor evidence of sequence learning on the serial reaction time task. *Mem Cognit* 34: 420-432, 2006.
- Martin TA, Keating JG, Goodkin HP, Bastian AJ, and Thach WT. Throwing while looking through prisms. I. Focal olivocerebellar lesions impair adaptation. *Brain* 119 ( Pt 4): 1183-1198, 1996.
- Matsuzaka Y, Picard N, and Strick PL. Skill representation in the primary motor cortex after long-term practice. *J Neurophysiol* 97: 1819-1832, 2007.
- McHugh DE, and Bahill AT. Learning to track predictable target waveforms without a time delay. *Invest Ophthalmol Vis Sci* 26: 932-937, 1985.
- McKenzie AL, Nagarajan SS, Roberts TP, Merzenich MM, and Byl NN. Somatosensory representation of the digits and clinical performance in patients with focal hand dystonia. *Am J Phys Med Rehabil* 82: 737-749, 2003.
- Miall RC. The cerebellum, predictive control and motor coordination. *Novartis Found Symp* 218: 272-284; discussion 284-290, 1998.
- Miall RC, Weir DJ, and Stein JF. Visuo-motor tracking during reversible inactivation of the cerebellum. *Exp Brain Res* 65: 455-464, 1987.

- Middleton FA, and Strick PL. Cerebellar projections to the prefrontal cortex of the primate. *J Neurosci* 21: 700-712, 2001.
- Mikhail C, Korner-Bitensky N, Rossignol M, and Dumas JP. Physical therapists' use of interventions with high evidence of effectiveness in the management of a hypothetical typical patient with acute low back pain. *Phys Ther* 85: 1151-1167, 2005.
- Molinari M, Leggio MG, Solida A, Ciorra R, Misciagna S, Silveri MC, and Petrosini L. Cerebellum and procedural learning: evidence from focal cerebellar lesions. *Brain* 120 ( Pt 10): 1753-1762, 1997.
- Morton SM, and Bastian AJ. Cerebellar control of balance and locomotion. *Neuroscientist* 10: 247-259, 2004a.
- Morton SM, and Bastian AJ. Prism adaptation during walking generalizes to reaching and requires the cerebellum. *J Neurophysiol* 92: 2497-2509, 2004b.
- Murphy BJ, Kowler E, and Steinman RM. Slow oculomotor control in the presence of moving backgrounds. *Vision Res* 15: 1263-1268, 1975.
- Naito E, Nakashima T, Kito T, Aramaki Y, Okada T, and Sadato N. Human limb-specific and non-limb-specific brain representations during kinesthetic illusory movements of the upper and lower extremities. *Eur J Neurosci* 25: 3476-3487, 2007.
- Nasir SM, and Ostry DJ. Somatosensory precision in speech production. *Curr Biol* 16: 1918-1923, 2006.
- Nissen MJ, and Bullemer P. Attention Requirements of Learning: Evidence from Performance Measures. *Cognit Psychol* 19: 1-32, 1987.

- Nixon PD, and Passingham RE. The cerebellum and cognition: cerebellar lesions impair sequence learning but not conditional visuomotor learning in monkeys. *Neuropsychologia* 38: 1054-1072, 2000.
- Nowak DA, Glasauer S, and Hermsdorfer J. How predictive is grip force control in the complete absence of somatosensory feedback? *Brain* 127: 182-192, 2004.
- Nowak DA, Hermsdorfer J, Timmann D, Rost K, and Topka H. Impaired generalization of weight-related information during grasping in cerebellar degeneration. *Neuropsychologia* 43: 20-27, 2005.
- Nudo RJ, Friel KM, and Delia SW. Role of sensory deficits in motor impairments after injury to primary motor cortex. *Neuropharmacology* 39: 733-742, 2000.
- Nudo RJ, Larson D, Plautz EJ, Friel KM, Barbay S, and Frost SB. A squirrel monkey model of poststroke motor recovery. *Ilar J* 44: 161-174, 2003.
- O'Sullivan SB. Strategies to Improve Motor Control and Motor Learning. In: *Physical Rehabilitation: Assessment and Treatment*, edited by O'Sullivan SB, and Schmitz TJ. Philadelphia: F. A. Davis Co., 2000, p. 177-212.
- Oldfield RC. The assessment and analysis of handedness: the Edinburgh inventory. *Neuropsychologia* 9: 97-113, 1971.
- Paine RW, Grossberg S, and Van Gemmert AW. A quantitative evaluation of the AVITEWRITE model of handwriting learning. *Hum Mov Sci* 23: 837-860, 2004.
- Parsons LM, Bower JM, Gao JH, Xiong J, Li J, and Fox PT. Lateral cerebellar hemispheres actively support sensory acquisition and discrimination rather than motor control. *Learn Mem* 4: 49-62, 1997.

- Pascual-Leone A, Bartres-Faz D, and Keenan JP. Transcranial magnetic stimulation: studying the brain-behaviour relationship by induction of 'virtual lesions'. *Philos Trans R Soc Lond B Biol Sci* 354: 1229-1238, 1999.
- Pavlidis C, Miyashita E, and Asanuma H. Projection from the Sensory to the Motor Cortex is Important in Learning Motor Skills in the Monkey. *J Neurophysiol* 70: 733-741, 1993.
- Pearson K, and Gordon J. Spinal Reflexes. In: *Principles of Neural Science*, edited by Kandel ER, Schwartz JH, and Jessell TM. New York: McGraw-Hill, 2000, p. 718-720.
- Pew RW. Levels of analysis in motor control. *Brain Res* 71: 393-400, 1974.
- Pipereit K, Bock O, and Vercher JL. The contribution of proprioceptive feedback to sensorimotor adaptation. *Exp Brain Res* 174: 45-52, 2006.
- Pohl PS, McDowd JM, Filion DL, Richards LG, and Stiers W. Implicit learning of a perceptual-motor skill after stroke. *Phys Ther* 81: 1780-1789, 2001.
- Polit A, and Bizzi E. Characteristics of motor programs underlying arm movements in monkeys. *J Neurophysiol* 42: 183-194, 1979.
- Polit A, and Bizzi E. Processes controlling arm movements in monkeys. *Science* 201: 1235-1237, 1978.
- Porter LL, and Sakamoto K. Organization and Synaptic Relationships of the Projection From the Primary Sensory to the Primary Motor Cortex in the Cat. *J Comp Neurol* 271: 387-396, 1988.
- Priplata AA, Niemi JB, Harry JD, Lipsitz LA, and Collins JJ. Vibrating insoles and balance control in elderly people. *Lancet* 362: 1123-1124, 2003.

- Priplata AA, Patriitti BL, Niemi JB, Hughes R, Gravelle DC, Lipsitz LA, Veves A, Stein J, Bonato P, and Collins JJ. Noise-enhanced balance control in patients with diabetes and patients with stroke. *Ann Neurol* 59: 4-12, 2006.
- Prochazka A, and Gorassini M. Models of ensemble firing of muscle spindle afferents recorded during normal locomotion in cats. *J Physiol* 507 ( Pt 1): 277-291, 1998.
- Quaney BM, Rotella DL, Peterson C, and Cole KJ. Sensorimotor Memory For Fingertip Forces: Evidence For A Task-Independent Motor Memory. *J Neurosci* 23: 1981-1986, 2003.
- Ramnani N, Toni I, Josephs O, Ashburner J, and Passingham RE. Learning- and expectation-related changes in the human brain during motor learning. *J Neurophysiol* 84: 3026-3035, 2000.
- Ramnani N, Toni I, Passingham RE, and Haggard P. The cerebellum and parietal cortex play a specific role in coordination: a PET study. *NeuroImage* 14: 899-911, 2001.
- Ren L, Khan AZ, Blohm G, Henriques DY, Sergio LE, and Crawford JD. Proprioceptive guidance of saccades in eye-hand coordination. *J Neurophysiol* 96: 1464-1477, 2006.
- Restuccia D, Della Marca G, Valeriani M, Leggio MG, and Molinari M. Cerebellar damage impairs detection of somatosensory input changes. A somatosensory mismatch-negativity study. *Brain* 130: 276-287, 2007.
- Richter S, Maschke M, Timmann D, Konczak J, Kalenscher T, Illenberger AR, and Kalveram K. Adaptive motor behavior of cerebellar patients during exposure to unfamiliar external forces. *J Mot Behav* 36: 28-38, 2004.
- Roll JP, and Vedel JP. Kinaesthetic role of muscle afferents in man, studied by tendon vibration and microneurography. *Exp Brain Res* 47: 177-190, 1982.

- Roll JP, Vedel JP, and Ribot E. Alteration of proprioceptive messages induced by tendon vibration in man: a microneurographic study. *Exp Brain Res* 76: 213-222, 1989.
- Rothwell JC, Traub MM, Day BL, Obeso JA, Thomas PK, and Marsden CD. Manual motor performance in a deafferented man. *Brain* 105 (Pt 3): 515-542, 1982.
- Sacco RL, Bello JA, Traub R, and Brust JC. Selective proprioceptive loss from a thalamic lacunar stroke. *Stroke* 18: 1160-1163, 1987.
- Sakai K, Hikosaka O, and Nakamura K. Emergence of rhythm during motor learning. *Trends Cogn Sci* 8: 547-553, 2004.
- Sakai K, Kitaguchi K, and Hikosaka O. Chunking during human visuomotor sequence learning. *Exp Brain Res* 152: 229-242, 2003.
- Sakamoto K, Arissian K, and Asanuma H. Functional role of the sensory cortex in learning motor skills in cats. *Brain Research* 503: 258-264, 1989.
- Salamon N, Sicotte N, Drain A, Frew A, Alger JR, Jen J, Perlman S, and Salamon G. White matter fiber tractography and color mapping of the normal human cerebellum with diffusion tensor imaging. *J Neuroradiol* 34: 115-128, 2007.
- Salmoni AW, Schmidt RA, and Walter CB. Knowledge of results and motor learning: a review and critical reappraisal. *Psychol Bull* 95: 355-386, 1984.
- Sanger TD, and Merzenich MM. Computational model of the role of sensory disorganization in focal task-specific dystonia. *J Neurophysiol* 84: 2458-2464, 2000.
- Santos MJ, Liu H, and Liu W. Unloading reactions in functional ankle instability. *Gait Posture* 2007.
- Schlerf JE, Spencer RM, Zelaznik HN, and Ivry RB. Timing of rhythmic movements in patients with cerebellar degeneration. *Cerebellum* 6: 221-231, 2007.

- Schmahmann JD, Doyon J, Toga AW, Petrides M, and Evans AC. *MRI Atlas of the Human Cerebellum*. San Diego, CA: Academic Press, 2000.
- Schmahmann JD, and Sherman JC. The cerebellar cognitive affective syndrome. *Brain* 121 (Pt 4): 561-579, 1998.
- Schmid M, De Nunzio AM, and Schieppati M. Trunk muscle proprioceptive input assists steering of locomotion. *Neurosci Lett* 384: 127-132, 2005.
- Schmidt RA. A Schema Theory of Discrete Motor Skill Learning. *Psychol Rev* 82: 225-260, 1975.
- Schmidt RA, and Lee TD. Ch. 10 - Motor Learning Concepts and Research Methods. In: *Motor control and learning: a behavior emphasis*. Champaign, IL: Human Kinetics, 1999a.
- Schmidt RA, and Lee TD. *Motor Control and Learning: A Behavioral Approach*. Champaign, IL: Human Kinetics, 1999b.
- Schmitz-Hubsch T, du Montcel ST, Baliko L, Berciano J, Boesch S, Depondt C, Giunti P, Globas C, Infante J, Kang JS, Kremer B, Mariotti C, Melegh B, Pandolfo M, Rakowicz M, Ribai P, Rola R, Schols L, Szymanski S, van de Warrenburg BP, Durr A, Klockgether T, and Fancellu R. Scale for the assessment and rating of ataxia: development of a new clinical scale. *Neurology* 66: 1717-1720, 2006.
- Schoner G, and Kelso JA. Dynamic pattern generation in behavioral and neural systems. *Science* 239: 1513-1520, 1988.
- Schwartz AB, and Moran DW. Motor cortical activity during drawing movements: population representation during lemniscate tracing. *J Neurophysiol* 82: 2705-2718, 1999.

- Seidler RD, Purushotham A, Kim SG, Ugurbil K, Willingham D, and Ashe J. Cerebellum activation associated with performance change but not motor learning. *Science* 296: 2043-2046, 2002.
- Sessle BJ, and Wiesendanger M. Structural and functional definition of the motor cortex in the monkey (*Macaca fascicularis*). *J Physiol* 323: 245-265, 1982.
- Shadmehr R, and Mussa-Ivaldi FA. Adaptive representation of dynamics during learning of a motor task. *J Neurosci* 14: 3208-3224, 1994.
- Shanks DR, Rowland LA, and Ranger MS. Attentional load and implicit sequence learning. *Psychol Res* 69: 369-382, 2005.
- Shea CH, Park JH, and Braden HW. Age-related effects in sequential motor learning. *Phys Ther* 86: 478-488, 2006.
- Shea CH, Wulf G, Whitacre CA, and Park JH. Surfing the implicit wave. *Q J Exp Psychol A* 54: 841-862, 2001.
- Sherrington CS. The integrative action of the nervous system. New Haven, CT: Yale University Press, 1906.
- Sittig AC, Denier van der Gon JJ, and Gielen CC. The contribution of afferent information on position and velocity to the control of slow and fast human forearm movements. *Exp Brain Res* 67: 33-40, 1987.
- Sittig AC, Denier van der Gon JJ, Gielen CC, and van Wijk AJ. The attainment of target position during step-tracking movements despite a shift of initial position. *Exp Brain Res* 60: 407-410, 1985.
- Smania N, Montagnana B, Faccioli S, Fiaschi A, and Aglioti SM. Rehabilitation of somatic sensation and related deficit of motor control in patients with pure sensory stroke. *Arch Phys Med Rehabil* 84: 1692-1702, 2003.

- Sober SJ, and Sabes PN. Multisensory integration during motor planning. *J Neurosci* 23: 6982-6992, 2003.
- Soso MJ, and Fetz EE. Responses of identified cells in postcentral cortex of awake monkeys during comparable active and passive joint movements. *J Neurophysiol* 43: 1090-1110, 1980.
- Spencer RM, Zelaznik HN, Diedrichsen J, and Ivry RB. Disrupted timing of discontinuous but not continuous movements by cerebellar lesions. *Science* 300: 1437-1439, 2003.
- Steinbach MJ, and Held R. Eye tracking of observer-generated target movements. *Science* 161: 187-188, 1968.
- Steinman RM, Haddad GM, Skavenski AA, and Wyman D. Miniature eye movement. *Science* 181: 810-819, 1973.
- Sterner RL, Pincivero DM, and Lephart SM. The effects of muscular fatigue on shoulder proprioception. *Clin J Sport Med* 8: 96-101, 1998.
- Taub E, Ellman SJ, and Berman AJ. Deafferentation in monkeys: effect on conditioned grasp response. *Science* 151: 593-594, 1966.
- Taub E, Williams M, Barro G, and Steiner SS. Comparison of the performance of deafferented and intact monkeys on continuous and fixed ratio schedules of reinforcement. *Exp Neurol* 58: 1-13, 1978.
- Thach WT. On the mechanism of cerebellar contributions to cognition. *Cerebellum* 6: 163-167, 2007.
- Thomas JR, Salazar W, and Landers DM. What is missing in  $p < .05$ ? Effect size. *Res Q Exerc Sport* 62: 344-348, 1991.
- Thoroughman KA, and Shadmehr R. Electromyographic correlates of learning an internal model of reaching movements. *J Neurosci* 19: 8573-8588, 1999.

- Thoroughman KA, and Shadmehr R. Learning of action through adaptive combination of motor primitives. *Nature* 407: 742-747, 2000.
- Vakil E, Kahan S, Huberman M, and Osimani A. Motor and non-motor sequence learning in patients with basal ganglia lesions: the case of serial reaction time (SRT). *Neuropsychologia* 38: 1-10, 2000.
- van Deursen RW, Sanchez MM, Ulbrecht JS, and Cavanagh PR. The role of muscle spindles in ankle movement perception in human subjects with diabetic neuropathy. *Exp Brain Res* 120: 1-8, 1998.
- Vaziri S, Diedrichsen J, and Shadmehr R. Why does the brain predict sensory consequences of oculomotor commands? Optimal integration of the predicted and the actual sensory feedback. *J Neurosci* 26: 4188-4197, 2006.
- Vedel JP, and Roll JP. Muscle Spindle Contribution to the Coding of Motor Activities in Man. *Exp Brain Res Suppl.* 7: 253-265, 1983.
- Vercher JL, Gauthier GM, Guedon O, Blouin J, Cole J, and Lamarre Y. Self-moved target eye tracking in control and deafferented subjects: roles of arm motor command and proprioception in arm-eye coordination. *J Neurophysiol* 76: 1133-1144, 1996.
- Vercher JL, Lazzari S, and Gauthier G. Manuo-ocular coordination in target tracking. II. Comparing the model with human behavior. *Biol Cybern* 77: 267-275, 1997.
- Vercher JL, Sares F, Blouin J, Bourdin C, and Gauthier G. Role of sensory information in updating internal models of the effector during arm tracking. *Prog Brain Res* 142: 203-222, 2003.
- Verschueren SM, Swinnen SP, Cordo PJ, and Dounskaia NV. Proprioceptive control of multijoint movement: unimanual circle drawing. *Exp Brain Res* 127: 171-181, 1999.

- Vidoni ED, and Boyd LA. Achieving enlightenment: what do we know about the implicit learning system and its interaction with explicit knowledge? *J Neurol Phys Ther* 31: 145-154, 2007.
- Waincott SK, Donchin O, and Shadmehr R. Internal models and contextual cues: encoding serial order and direction of movement. *J Neurophysiol* 93: 786-800, 2005.
- Wells C, Ward LM, Chua R, and Timothy Inglis J. Touch noise increases vibrotactile sensitivity in old and young. *Psychol Sci* 16: 313-320, 2005.
- Willingham DB, and Goedert-Eschmann K. The Relation Between Implicit and Explicit Learning: Evidence for Parallel Development. *Psych Sci* 10: 531-534, 1999.
- Winstein CJ, Merians AS, and Sullivan KJ. Motor learning after unilateral brain damage. *Neuropsychologia* 37: 975-987, 1999.
- Winstein CJ, Pohl PS, and Lewthwaite R. Effects of physical guidance and knowledge of results on motor learning: support for the guidance hypothesis. *Res Q Exerc Sport* 65: 316-323, 1994.
- Witney AG, Goodbody SJ, and Wolpert DM. Predictive motor learning of temporal delays. *J Neurophysiol* 82: 2039-2048, 1999.
- Witney AG, and Wolpert DM. Spatial Representation of Predictive Motor Learning. *J Neurophysiol* 89: 1837-1843, 2003.
- Woldag H, and Hummelsheim H. Evidence-based physiotherapeutic concepts for improving arm and hand function in stroke patients: a review. *J Neurol* 249: 518-528, 2002.
- Wolpert DM, Ghahramani Z, and Jordan MI. An internal model for sensorimotor integration. *Science* 269: 1880-1882, 1995.
- Wolpert DM, Goodbody SJ, and Husain M. Maintaining internal representations: the role of the human superior parietal lobe. *Nat Neurosci* 1: 529-533, 1998.

- Wu C, Trombly CA, Lin K, and Tickle-Degnen L. A kinematic study of contextual effects on reaching performance in persons with and without stroke: influences of object availability. *Arch Phys Med Rehabil* 81: 95-101, 2000.
- Wu C, Trombly CA, Lin K, and Tickle-Degnen L. Effects of object affordances on reaching performance in persons with and without cerebrovascular accident. *Am J Occup Ther* 52: 447-456, 1998.
- Wulf G, Horger M, and Shea CH. Benefits of Blocked Over Serial Feedback on Complex Motor Skill Learning. *J Mot Behav* 31: 95-103, 1999.
- Wulf G, McNevin NH, Fuchs T, Ritter F, and Toole T. Attentional focus in complex skill learning. *Res Q Exerc Sport* 71: 229-239, 2000.
- Wulf G, and Schmidt RA. Variability of practice and implicit motor learning. *Journal of Experimental Psychology: Learning, Memory, and Cognition* 23: 987-1006, 1997.
- Wulf G, and Shea CH. Principles derived from the study of simple skills do not generalize to complex skill learning. *Psychon Bull Rev* 9: 185-211, 2002.
- Wulf G, and Toole T. Physical assistance devices in complex motor skill learning: benefits of a self-controlled practice schedule. *Res Q Exerc Sport* 70: 265-272, 1999.
- Ziemann U, Muellbacher W, Hallett M, and Cohen LG. Modulation of practice-dependent plasticity in human motor cortex. *Brain* 124: 1171-1181, 2001.

## Appendix 1

### *Target Waveform Creation*

One thousand sets of 12 random numbers between -10 and 10 were generated using Microsoft Excel and rounded to the nearest tenth. Wulf and Schmidt's (Wulf and Schmidt) original coefficient set was doubled to create the repeated sequence epoch coefficient set:  $b_0 = 4.0$ ,  $a_1 = -8.0$ ,  $b_1 = 6.0$ ,  $a_2 = -8.0$ ,  $b_2 = -7.2$ ,  $a_3 = 7.8$ ,  $b_3 = 9$ ,  $a_4 = 0.0$ ,  $b_4 = 2.0$ ,  $a_5 = -7.6$ ,  $b_5 = -1.0$ ,  $a_6 = 2.0$ ,  $b_6 = 5.0$ . Coefficients were substituted into Equation 1:

$$\text{(Eq.1): } \theta(i) = b_0 + a_1\sin(\theta) + b_1\cos(\theta) + a_2\sin(2\theta) + b_2\cos(2\theta) + a_3\sin(3\theta) \dots \\ + b_3\cos(3\theta) + a_4\sin(4\theta) + b_4\cos(4\theta) + a_5\sin(5\theta) + b_5\cos(5\theta) + a_6\sin(6\theta) + b_6\cos(6\theta)$$

where:

$$\text{(Eq.2): } \theta(i) = 2\pi(i + \phi) / 800 \text{ and } \phi = 35.$$

Coefficient sets with a resultant wave range greater than 10% of the repeated epoch range were discarded to ensure no large changes in movement magnitude between trials and more uniformity between random and repeated epochs. Remaining waveforms were corrected vertically ( $b_0$ ) to ensure equidistant minima and maxima from the midline.

Next, to ensure target wave epochs transitioned smoothly, a phase shift ( $\phi$ ) was induced in all resultant curves. This was accomplished by identifying all midline crossing points and calculating the first derivative of the point. Crossing points were tested against the initial slope of the repeated segment. The first point with a slope that differed by less than 20% was

used as the phase shift. If no point in the waveform met this criterion, the coefficient set was discarded. Remaining random waveform epochs were substituted into the target wave in order of their creation. Random waveforms were never reused. For each trial, a 3s level baseline was followed by a random epoch and the repeated sequence epoch, in random order.

## Appendix 2

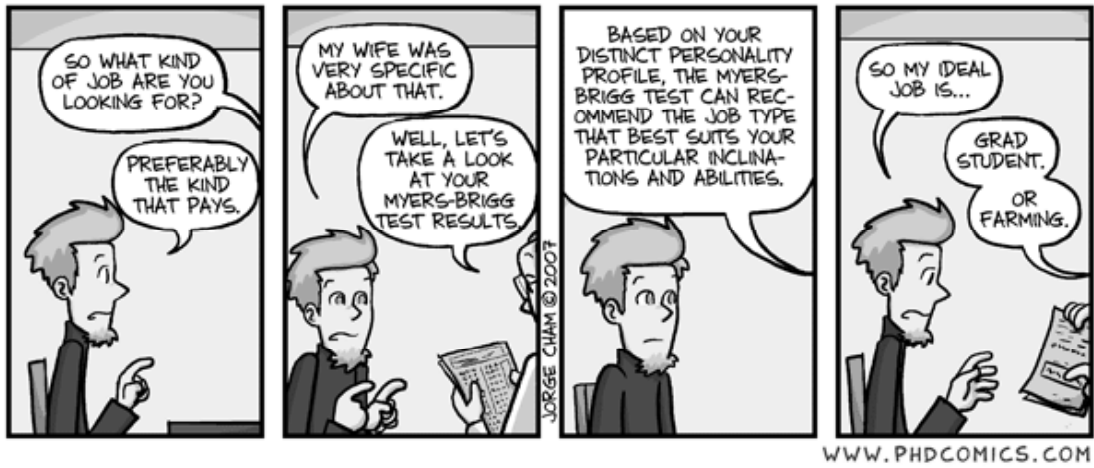

Used with permission. "Piled Higher and Deeper" by Jorge Cham  
www.phdcomics.com. (Cham 2007)