

CREATING A SEALSTONE

A Study of Seals in the Greek Late Bronze Age

JOHN G. YOUNGER

Our evidence for the techniques of creating a sealstone in the Greek Late Bronze Age (roughly 1600-1200 B.C.) comes almost exclusively from the stones themselves. Some are unfinished or altered, revealing the artist's process through his common errors and lapses; others, though finished, still preserve traces of the procedure. The reconstruction of the typical technique, as presented here, does not differ greatly from that employed during Classical antiquity, for which we have not only similar evidence but also the remarks of the ancient authors, notably Pliny (*Historiae Naturalis* book 37) and Theophrastos (*De Lapidibus*). The following observations about the process of creating a sealstone refer specifically to the Late Bronze Age in Greece however, and indeed only to the years 1600-1300 B.C., since there is no indisputable evidence for sealstone manufacture in the 13th century B.C.

For the sake of brevity, this paper omits detailed descriptions of several peripheral subjects, like the various mountings and the staining or heating of the stones (see Pini X: 17-18), and treats the main process of creating a seal in its chronological order.

THE WORKSHOP

It need not be assumed that each palace had its own workshop. Knossos certainly did, and so did Kato Zakro, Thebes, and undoubtedly Mycenae. Many of the other palaces probably commissioned seals for their bureaucracy from several masters who traveled about or sold their works far afield. A reasonable estimate of the masters indicates that approximately five per generation (each twenty-five years from 1600-1300 B.C.), a total of sixty, could be responsible for the approximately 4500 sealstones extant. We may also expect that each workshop consisted of a master, his apprentice (later to succeed his master), and a helper.

An early (Middle Minoan I-IIB, ca. 1800-1750 B.C.) sealstone workshop has been excavated at Mallia, where early three-sided steatite (hardness ca. 2 on the Mohs scale) prisms were made; the seals that broke during engraving were heaped together in a corner of the room (Pini II 2 nos. 86-198).

TOOLS

Tools were also found in the Mallia workshop: bronze saws for shaping the seal, blades of Melian obsidian (hardness ca. 5), bronze needles for gouging, remnants of bronze drills, and bone points and scrapers. There were a basin for water, and lumps of clay, probably for taking impressions to check the work's progress.

Only three seals from the Mallia workshop, all three unusual there, carry the ring-like circles and arcs that must have been made by a tubular drill (compare the similar circles and arcs on a trial piece, Fig. 1). That these three seals are in harder materials and in shapes and with motifs that are slightly more advanced than the rest of the seals from the workshop may indicate that the tubular drill was a com-

Note
Photographs of seals have been enlarged. Actual size of each seal is given in its caption.

1
Though poorly shaped, this amygdaloid seal in the Herakleion Museum (no. 985; 2.0 x 1.4 cm.) was nonetheless engraved with the tubular drill and wheel, probably as a trial piece.



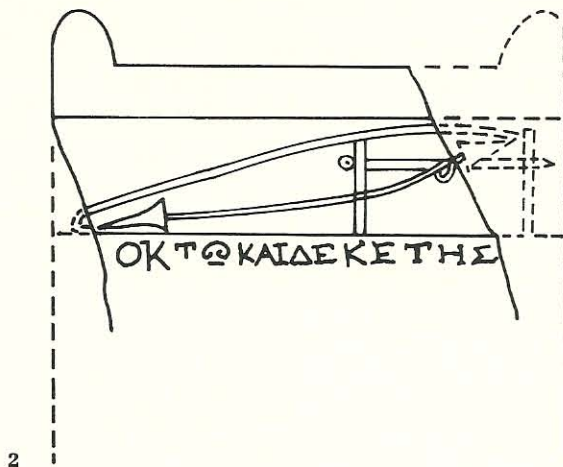

2

2 This fragment of the tombstone for Doros the engraver of ring stones of Philadelphia in Lydia, who died unmarried at age 18 in the second century A.D., depicts his bow lathe. The stela used to be in a private house in Izmir (preserved height 74 cm., width 30 cm.).

3 The rim of this unfinished lentoid, like the one pictured in Figs. 12 and 13, shows the small hole made to secure it in place while the artist sketched the composi-

tion. The seal is in the Herakleion Museum (no. 607, diameter 1.8 cm.).

4 Reconstruction of a wooden stand to hold a lentoid seal conveniently while the engraver sketched the design.

5 Raked for easy engraving, this object, now in the Ashmolean Museum (no. 1938.1087, height and diameter about 1.8 cm.), was probably used to transfer its design to gold foil in a process that resembles brass-rubbing.

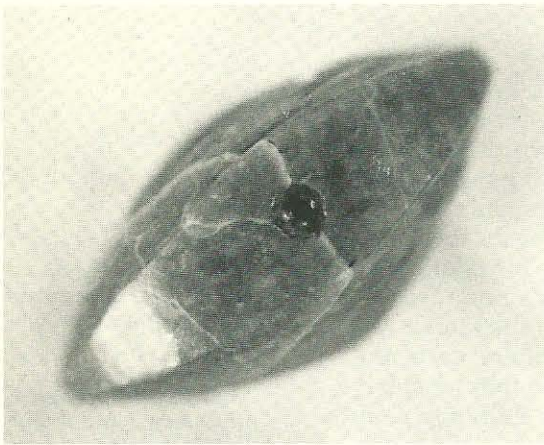

3

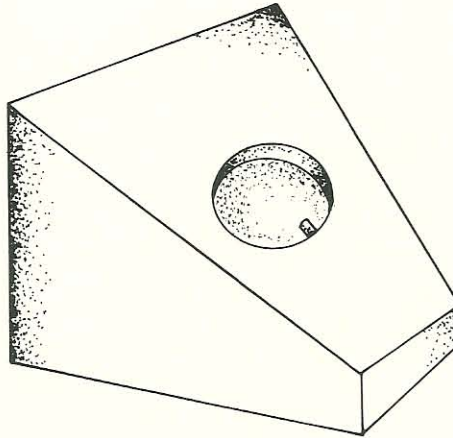

4



5

paratively recent tool when the workshop was abandoned. Such drills were made of rolled tubes of bronze or copper.

Egyptian frescoes show the drills held in one hand and run by a bow held in the other. A Roman tombstone from Lydia (Fig. 2) perhaps shows the same kind of drill mounted on a fixed horizontal lathe also run by the bow, similar to a tool hypothesized for Mesopotamian seal engraving. Perhaps the first drills were hand-held, pushed against the seal by the engraver's chest or hand and turned by a bow drawn in the other hand, but it seems reasonable to suppose that fixed drills, requiring the seal to be moved, would soon have been introduced or invented, probably about 1700 B.C.

To drill stones harder than the copper or bronze drills, corundum or emery from Naxos was used as an abrasive along with

the drills; this material was famous in antiquity and seems to have been used also for filling the otherwise hollow gold rings of the Late Bronze Age.

One more tool can be deduced. After the shape was created and before engraving was begun, a small hole was often drilled into the bottom rim of lentoids (Fig. 3). Such a hole may have been used to secure the lentoid to a raked stand, perhaps of wood (Fig. 4), as the design was being lightly sketched with a sharp blade, perhaps of obsidian; a similarly raked stand, but of stone and engraved with a cow suckling a calf, comes from the Lapidary's Workshop at Knossos and was probably used as the mold for a gold plate (Fig. 5). Presumably, too, the securing hole drilled into such lentoids would be used to start the stringhole after the engraving was finished.

6, 7
 These two lentoids (Pini I nos. 140 and 141, diameters about 2.2 cm.) were found in the same tomb at Mycenae. Though they were cut from one large block of agate, the styles of the animals, a lion on one and a cow and calf on the other, are dissimilar enough to suggest two different artists.



Several scholars have also thought that the small pieces of rock crystal found in several tombs as well as in the stone workshop located in the Kadmeion palace at Thebes might be magnifying glasses. If they were, they do not magnify well or clearly; they might have been used, however, to check the progress of the work, but surely not while the work was actually going on. In any case, it should be remembered that miniature effects are for dazzling the unaided eye; and in a culture that did not have spectacles, gem engraving would have been the esteemed preserve of the nearsighted (see Gorelick and Gwinnett 1981).

8, 9
 The subtle vein patterns of these three limestone lentoids, two from the Temple at Ayia Irini in Keos (Pini V 499 and 500, diameters about 1.8 cm.) and one from the Sanctuary at Phylakopi in Melos (Melos Museum no. 57, diameter about 1.9 cm.), show these too to have been cut from one block. The translucent quality of the stone renders the animals almost invisible, but they are all certainly the work of one artist.

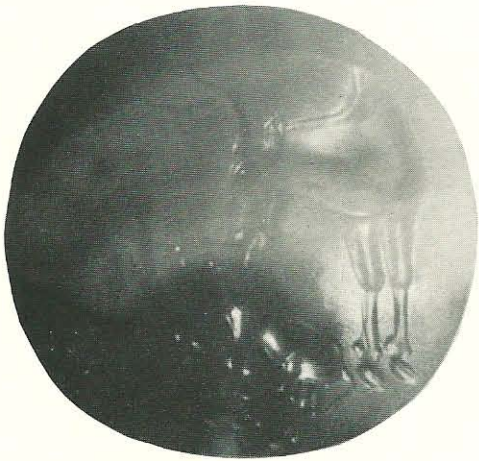

SHAPING THE SEAL

A few unfinished seals reveal some information about shaping. Several seals apparently could be carved from one die, as their distinctive colors or veins reveal, like the pair of agate lentoids from Mycenae (Figs. 6 and 7), and a trio of limestone lentoids consisting of two (Fig. 8) from Keos and one from Phylakopi (Fig. 9).

It may be assumed that cylinders were shaped from cores made by the tubular drill. The diameters of most are relatively standard (0.7 to 1.0 cm.), with the average being 0.8-0.9 cm. While seals from soft stones like steatite could be shaped directly with a knife, the drill may also have been used to prepare other shapes than just

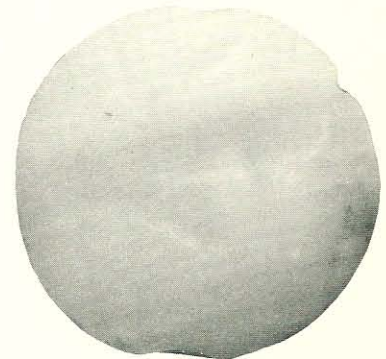
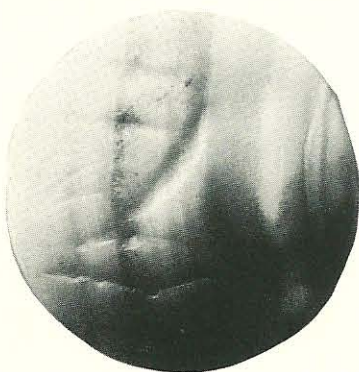

8

9

cylinders. A few seals, like the cushion seal in Figs. 10 and 11, preserve drill borings in section, like that for the stringhole (Diam. 0.1-0.2 cm.), across the rim or on the face. Such marks suggest that a piece of hard stone, later to become the seal, could also be drilled away from its die with a drill.

The seal was then roughly shaped by the saw or file. The awkward amygdaloid (Fig. 1) seems to have been enthusiastically shaped too angular to be finished, though its face bears drill and saw marks that may have been a student's experiment. An unfinished lentoid of green steatite (Figs. 12 and 13) preserves the preliminary shaping, again with the saw or file, in broad rough facets (0.6-0.7 cm. wide). The presumed obverse carries one such cut, and the reverse shows six around a central flat cut. We may assume the obverse was intended to be gently convex, the reverse to be, as is often the case, more humped, conoid, or even conical.

It is generally agreed that the final shaping of the seal consisted of polishing the rough cuts with emery or fine sand, or with (olive?) oil applied with a soft piece of leather like modern chamois leather. The polishing in its initial stage can be seen on the unfinished Ashmolean lentoid, mentioned above, as abrasion marks moving in a clockwise direction on the obverse and longitudinally on the reverse.



10



11



12

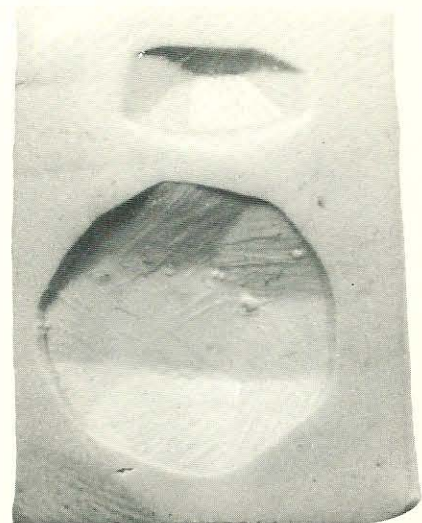

13

10, 11

Across the top rim of this cushion seal in the Ashmolean Museum (no. 1938.946, 1.9 x 1.4 cm.), depicting a running *agrimi* (Cretan wild goat), are preserved the marks of a tubular drill; the seal is odd in other respects too, for it is the only one with two stringholes.

12, 13

Another seal in the Ashmolean Museum (no. 1938.1089, diameter about 1.7 cm.), pictured also with an impression of its face and rim, shows clearly the straight cuts that were used to shape the seal and the abrasion marks made by polishing it with Naxian emery.

14, 15, 16

On the back (Fig. 15) of the lentoid CMS I 220 (diameter about 2.2 cm.) is the light sketch (Fig. 14) of the saluting woman engraved on the front, to be seen more clearly in the plasticine impression (Fig. 16).

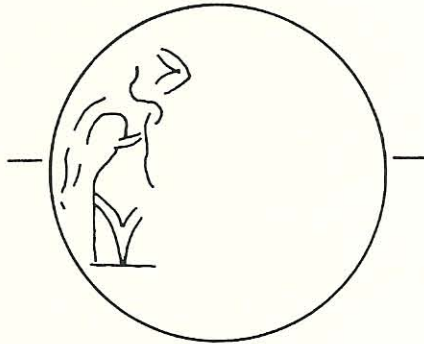

14



15



16

ENGRAVING THE MOTIF: SKETCHES

The repertory of motifs for Late Bronze Age seals is so small that cartoons were probably not needed, though a few sketches on Linear B tablets and crude or unfinished engravings on stone have been mentioned as candidates. Artists, like their patrons, surely collected sealstones on which they could base their own versions of the accepted motifs not only for seals but also in other media; one such artist is the Late Minoan IB (ca. 1450 B.C.) ivory cutter at Knossos who kept his seals in an ivory box.

While he does not seem to have used cartoons, the seal engraver did, however, sketch the composition on the seal face to position it properly.

Four lentoids preserve such sketches. The present reverse of a lentoid from the Vapheio Tholos (Fig. 14) carries the light engraving of a headless woman on the left of the stone, corresponding in position and attitude to the extra woman on the obverse. She was probably intended to be the woman crossed by the sheep now on the obverse (Figs. 15 and 16), and if so she is correctly aligned perpendicular to the short axis of the stone through which the stringhole would pass horizontally, as is normal for this sacred motif (see last paragraph). Perhaps, however, the artist realized that his woman was placed too far off-

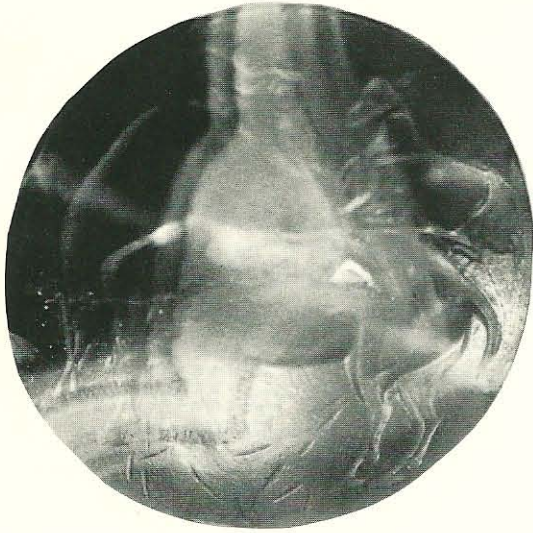

17



18

17, 18
Under the nanny on this lentoid in the Herakleion Museum (no. 908, diameter about 2.2 cm.) is the sketch of an unfinished suckling kid; over the nanny is his finished twin. Why only one was finished is not known.

19, 20
Of the intended composition on this lentoid, also in the Herakleion Museum (no. 607, diameter about 1.8 cm.), only half of one of the lions flanking a column was completed; the rest of the design is only sketched in short light strokes.

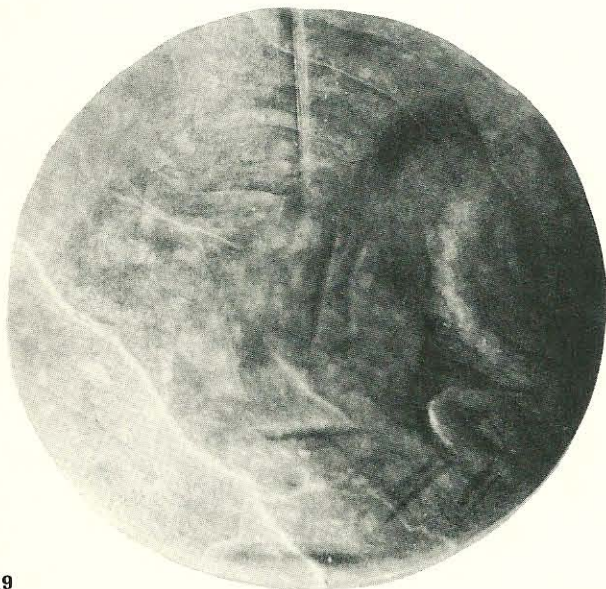

19

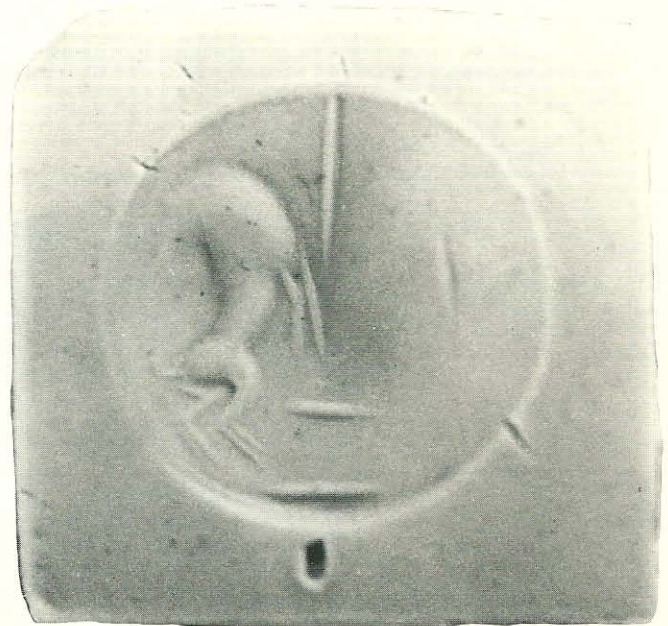

20

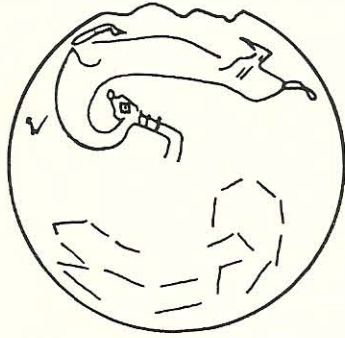
**21**

Two *agrimia* run counterclockwise around this lentoid in Berlin (no. FG29, diameter about 2.0 cm.), but only one is at all finished, its front leg only indicated; the other *agrimi* is sketched, the line of the head coming down to meet the pronounced shoulder.

center, that another woman with the sheep could be squeezed in, but that the composition's standard form would thereby have been violated, thus needing a secular, vertical stringhole. So he turned the seal over and around 90° and began afresh, this time with his new (and unique) composition oriented so that the shorter axis would be upright for the now vertical stringhole to be bored later.

A lentoid from Isopata near Knossos (Figs. 17 and 18) preserved the sketch of a kneeling, suckling *agrimi* kid, partially modelled, under its nanny, above whom is another and finished kid. This composition, had it been completed, would also have been unique.

Another unfinished lentoid (Figs. 19 and 20) was intended to depict two lions rampant on a waisted altar and flanking a central column. The position of one lion is indicated by only a few dashes; the other lion is modelled rather more but still preserves his schematic legs and pinched rump that no doubt would have been filled out.

The fourth sketch, on a lentoid now in Berlin (Fig. 21), presents two *agrimia* running in radial symmetry; one is almost completed, the other only lightly sketched.

All four sketches are done in short, extremely shallow strokes. The Isopata kid and Berlin *agrimi* are schematic, the sketches really only positioning the animals; the Vapheio woman is a bit more fulsome, probably because of the complexity of her dress. The Isopata kid and Berlin *agrimi* lack detailing to the head, the lion and the Vapheio woman lack a head altogether. Presumably, heads required special attention and could not be sketched in advance; perhaps they needed to grow organically.

Sketching the composition in short, detached, shallow strokes seems to have been the common procedure, one that was also followed in the Archaic and Classical periods, though the Egyptians seem to have sketched their designs on scarabs in ink. Not all artists, however, practiced any preliminary sketching, for there are unfinished seals with parts of the motif partially modelled, but no sketches.

The seals that do preserve sketched, as well as partially modelled, motifs, like the Isopata, Berlin, and Herakleion seals mentioned above, show that modelling was restricted to one part of a composition at a time and that the whole did not advance in parallel stages. Such was also the procedure for Classical seals.

Suggested Reading**Boardman, J.**
1970

Greek Gems and Finger Rings, London: Thames and Hudson

Gorelick, L. and A. J. Gwinnett
1981

"Close work without magnifying lenses?" *Expedition* 23, 2: 27-34

Kenna, V. E. G.
1960

Cretan Seals with a Catalogue of the Minoan Gems in the Ashmolean Museum, Oxford University Press

Pini, I.

1964-present
Corpus der minoischen-mykenischen Siegel, Verlag Gebrüder Mann

Younger, J. G.
1974

"A Glyptic Sketch from Isopata, HM 908," *Kadmos* 13 part 1: 1-5

1977

"Non-Sphragistic Uses of Minoan-Mycenaean Sealstones," *Kadmos* 16 part 2: 141-159

1979

"The Lapidary's Workshop at Knossos," *Annual of the British School of Archaeology at Athens* 74: 258-268

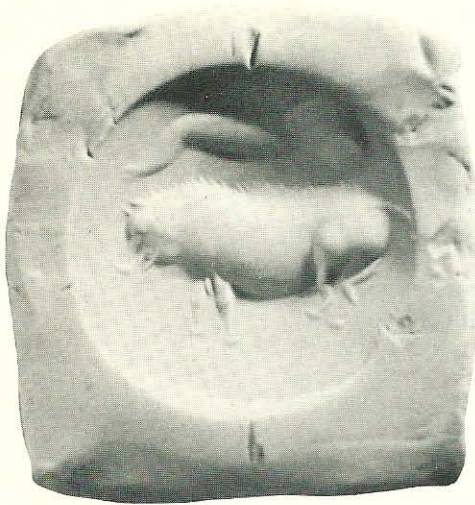

CHANGES IN OR ADDITIONS TO THE COMPOSITION

For various reasons the artist often changed the design as he worked. A lentoid from Midea (Fig. 22), for instance, originally was meant to have a bull attacked by a lion, but the motif was changed to a boar under a 'cloud' and bored for the stringhole perhaps because it was needed quickly as a tomb offering. Other seals preserve changes in the design that are difficult to explain and may actually bespeak changes in intention.

BORING THE STRINGHOLE

The final stage in carving a seal was the boring of the stringhole. If a securing hole had been bored, it was apparently used to begin the stringhole. Some seals were never bored, others had their stringholes changed.

The stringhole was bored from opposite sides of the seal to meet in the center. The drill (Diam. ca. 0.1-0.2 cm.) was inserted in each channel several times and at slightly different angles, thus creating both a mouth significantly wider and often only roughly circular and a drill channel with many ridges indicating the main insertions of the drill. This process can be seen clearly in seals of rock crystal like one from Phylakopi (Fig. 23) or in the very informative radiographs and photographs of silicone impressions of the stringholes of Near Eastern seals taken by L. Gorelick and J. Gwinnett. These reveal that one channel penetrated two-thirds of the stone, generally in four main insertions from the top, and the other met the first in three. Occasionally, however, there were mistakes and the drill broke through the

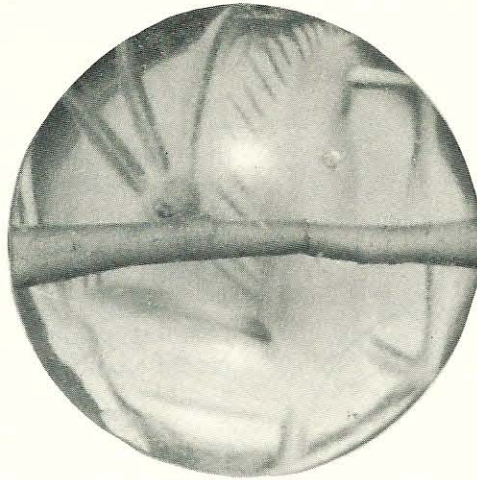

22

A plasticine impression of the lentoid Pini I 192 (diameter about 2.9 cm.) whose original design, a lion above and to the right attacking a bull below, was curtailed and changed to a rather clumsy boar.

23

The clarity of this rock crystal lentoid depicting a running *agrimi* allows us to see the stringhole clearly enough to appreciate the hard work and great care it took to make it. The seal will be published soon (Melos Museum 568, diameter about 2.4 cm.).

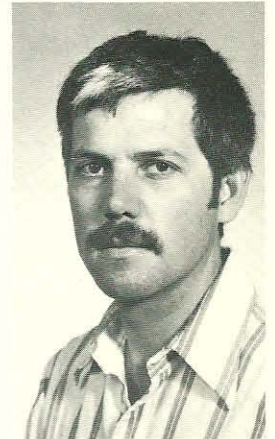

John G. Younger is an assistant professor in the Department of Classical Studies at Duke University. He received his Ph.D. in Classics in 1973 from the University of Cincinnati, the subject of his dissertation "Towards the Chronology for Aegean Glyptic in the Late Bronze Age." Dr. Younger has been a member of the American School of Classical Studies at Athens and of the British School of Archaeology at Athens; and since 1978 has been a traveling lecturer for the Archaeological Institute of America. He has excavated in Greece at Corinth (1970), Ayia Irini in Keos (1970), Knossos, Royal Road (1971) and Unexplored Mansion (1972), Ayios Stephanos, Skala Laconias (1973), Phylakopi in Melos (1975-1977). He is the author of numerous articles and reports in his field.

obverse or reverse face.

The stringhole was usually bored to produce more or less a straight channel, though there are exceptions. It almost always pierced the long axis of amygdaloids and cushions and generally the shorter axis of lentoids. Usually it is perpendicular to the veins of most stones. It would seem then that in almost all cases the shape and material of the stone and the alignment of the stringhole to it were inseparably linked.

More variable, however, is the alignment of motif to the stringhole; when the motif is upright, the stringhole is usually vertical in lentoids, discs, and prisms, and horizontal in amygdaloids (except those depicting the solitary human figure) and cushions. Motifs that do not follow this normal alignment almost invariably concern religious or otherwise special themes, including cult scenes, battles, and battle-gear. Thus the artist might have designed secular lentoids for bracelets, and amygdaloids and cushions for necklaces, and the sacred seals *vice versa*, though the people who wore them did so, of course, wheresoever they wished.