

INCORPORATIVE INFLECTION IN SGÜÜXS

John A. Dunn

University of Oklahoma

1. *Locale and Data.* SgüüXs is the name of a variety of Tsimshianic. It is the name its own speakers use for it. There are fewer than a dozen of these speakers left. They all live in two native reserve communities in British Columbia: Klemtu and Hartley Bay. For none of these remaining speakers is SgüüXs the dominant language variety. The SgüüXs data presented here were collected with the support of the Urgent Ethnology Division of the Canadian National Museums of Civilisation between 1972 and 1990.

2. *Paper Topic.* There are a number of discrete sets of inflectional phenomena in SgüüXs. Three of these focus on the pronominal features 'person' and 'number:' a) verb roots inflect to indicate the number of one of their arguments; b) a pronominal (person, number) enclitic attaches to the verb; c) a separate pronominal clitic attaches to some element before the verb.

The interaction of three straightforward and simple syntactic principles accounts for all three of these phenomena, integrating them into one, comprehensive grammatical system. The syntactic principles posited are these: 1) move-a'pha (understood to include incorporative or X⁰ (head) movement), 2) where such movement is consistently left-ward, 3) and where such movement is radically and consistently local, following the general intuitions of binding and bounding theory (Cf. Baker 1988:51-68).

In this discussion I have limited myself in the main to a consideration of simple monotransitive sentences.

3. Basic Word Order. Overt word order in SgüüXs is pre-verb material (conjunction, complementizer, negative marker, interrogative marker, and tense-aspect-mood elements), sentential predicate (the verb followed by its arguments). In positing a preliminary basic (d-structure) order I have not interdicted this overt order but have rather maintained it with some determination. For the sake of argument, then, a first approximation of the d-structure sentential template is

[pre-verb [vP V NP (NP)]].

For the sake of simplicity and clarity, I will henceforth refer to the pre-verb material as X:

[XP X [vP V NP (NP)]].

where XP consists of an hierarchy of nested phrasal entities all superordinate to the sentential predicate VP.

4. Verb Subcategorization. Three different subcategorites of verbs head the sentential predicate cores of intransitive and simple monotransitive sentences (cf. Chart 1).

V + [] <PATIENT>.
V + [NP] <agent>.
V + [NP] <agent,PATIENT>.

Chart 1. SgüüXs verb subcategorization (incomplete).

I here make a number of assumptions: 1) uniformity of theta assignment (Baker 1988:46), 2) maximal correspondence between overt word order and basic word order, 3) reduction of subcategorizing theta roles to two, (proto)agent and (proto)patient in the sense intended by Dowty (1987), and 4)

characterization of SgüüXs as a syntactically ergative language.

5. Inflection of the Verb Root. The verb root inflects to show the number of one of its participants. In the simple monotransitive the verb agrees with the argument that bears theta-patient role. Most SgüüXs verbs fall into one or another of a number of regular, phonologically 'motivated' reduplication classes or conjugations (Cf. Dunn 1979:13-26 for a treatment of these same conjugations in the closely related Coast Tsimshian). There are several lesser strategies for marking the number of the appropriate argument. I here assume that some variety of regular reduplication constitutes the default mechanism for verb root inflection. I further assume, as is the general fashion, that verb inflection involves incorporating the verb into some type of INFL node. For SgüüXs, in particular, I posit the existence of a d-structure, incorporating-inflecting node: AGR. This AGR coindexes the appropriate argument insofar as number is concerned, receives the verb and inflects it for that number (cf. Chart 2):

...AGR ₁ [V PATIENT ₁] → ...AGR ₁ -V ₁ [t ₁ PATIENT ₁]
...AGR ₁ [V agent e ₁] → ...AGR ₁ [V t ₂ [e agent ₂] ₁] → ...AGR ₁ -V ₁ [t ₁ t ₂ [e agent ₂] ₁],
...AGR ₁ [V agent PATIENT ₁] → ...AGR ₁ -V ₁ [t ₁ agent PATIENT ₁].

Chart 2. Incorporation of SgüüXs verbs into AGR.

5.1 SgüüXs Monotransitives with Reduplicative Verb Inflection. The following examples illustrate the default inflection of the monotransitive verb.

- 5.1.1 Si ts'ik ts'aXu k'uhba 'yu'uxwt.
 Si ts'ik ts'aX-u k'uhba 'yu'uxwt
 make plu nose-l little men
 I'm scolding the boys.
- 5.1.2 Si ts'aXu hku 'yaxwt.
 Si ts'aX-u hku 'yaxwt
 make nose-l little man
 I'm scolding the boy.
- 5.1.3 At aitgat i hku 'yu'uxwt.
 At ait-ga-t i hku 'yu'uxwt
 plu name-...-they case little men
 They're naming the boys.
- 5.1.4 Aitgat i hku 'yaxwt.
 Ait-ga-d i hku 'yaxwt
 name-...-they case little man
 They're naming the boy.

5.2 Verb Root Inflection as the Major Verb-Subject Agreement System in SgüüXs. The reduplicative mechanisms illustrated in 5.1.1 thru 5.1.4 constitute the major verb-subject agreement system in SgüüXs. This is true for several reasons. It is an 'agreement system proper' (Cf. LaPointe 1988:68-74), i.e., it manifests very common cross-linguistic morphosyntactic co-occurrence properties: (1) the controller is a noun phrase, (2) the controllee is a verb, (3) the agreement feature is 'number.' Secondly, the number agreement indication in the verb root is always obligatory through the whole pronominal paradigm. Furthermore, this verb root inflection shows a consistent relationship to canonical theta-marking, i.e., in monotonatives it always indicates the number of the argument that is theta-marked 'proto-patient.' Finally, the morphosyntactic regularity and low frequency of the inflected verbs indicate that the verb inflection involves a postlexical procedure. Cf. Stemberger and MacWhinney (1988:114). The fact that speakers do not often agree on the membership of the various conjugations and the fact that they indeed frequently

change a verb's conjugation membership, whether for stylistic or other reasons, both confirm that they are managing these phenomena postlexically. The other two inflection systems discussed in this paper lack one or more of these characteristics. For this reason I refer to them as 'minor agreement systems.'

In light of these facts the basic (d-structure) template for the monotransitive sentence must include an abstract nonlexical head, namely AGR:

[XP X [AGRP AGR₁ [V NP NP₁]].

6. The Pronominal Enclitic Affiliating with the Verb. The pronominal enclitic associated with the verb indicates person and number in the paradigm shown in Chart 3:

	singular	plural
speaker	-u,-du,-yu	-yim
addressee
other	-t	-t.

Chart 3. Pronominal enclitics inflecting the SgūūXs verb.

In intransitive sentences the enclitics are optional in all sentence types; they are in fact rarely used. When present they are always co-indexed by a non-agent argument. When present, the argument NP can pro-drop in third person and must pro-drop in at least some (and probably all) non-third person arguments. Cf. 6.0.1 thru 6.0.3 below.

6.0.1 Hla sxwu naahl u.
T be-tired 1st, sing.
I'm tired.

6.0.2 Hla wila tciaipk t.
T T be-hard 3rd
It's still hard.

- 6.0.3 Siipk t₁ q'am Gausu₁.
 hurt 3rd really my-head
 My head hurts.

In simple monotransitive sentences we must make a distinction between two kinds of material standing before the verb: unmarked (hence *uX*) and marked (hence *mX*). Cf. Chart 4 on the next page.

The <i>uX</i> elements illustrated in this data base:	
yagwi	present active
da, ada	conjunctions: and then
e	conjunction: well, now
(a)da wil	and then after that
ada hla	and then just now
hla	just now.
The <i>mX</i> elements illustrated in this data base:	
∅	past
nah	past perfect
nah hla	immediate past perfect
hla dim	immediate/incipient future
dim	present progressive.

Chart 4. The *uX* and *mX* preverbal elements.

When pronominal clitics are present for both arguments, the enclitic associated with the verb is always co-indexed by the non-agent argument:

- 6.0.4 Yagwi t niis t₁ i ol i dip niit₁.
 T CL see 3rd case bear case them
 The bear sees them.
- 6.0.5 Na t luu niidz u hoan.
 T CL glare at me fish
 The fish was glaring at me.

- 6.0.6 Yagwi t niis t i ol i hoan.
T CL see 3rd case bear case fish
The bear is staring at the fish.
- 6.0.7 Da t wil dzuhgwi t ga ol ga xwuhn.
T CL T kill 3rd case bear case deer
The bear killed the deer.
- 6.0.8 Yagwi t 'niis t i ol i nu waabu.
T CL see 3rd case bear case my-house
The bear is looking at my house.
- 6.0.9 Hla t ama niis t i ha na'aG i ts'iks na'as.
T CL get 3rd case woman case bracelets
The woman got the bracelets.

In simple monotransitive sentences with only one pronominal clitic, that clitic is always co-indexed by the agent argument. In sentences with *uX* there is no enclitic attached to the verb:

- 6.0.10 Yagwi t bahan i boat.
T CL run case
He is running the boat.
- 6.0.11 Yagwi t oic i lo'ap.
T CL throw case rock
He's throwing rocks.
- 6.0.12 Yagwi na ba'al i lo'ap.
T CL feel case rock
I am feeling of the rock.
- 6.0.13 Ada n nii an onu.
CONJ CL see my-hand
I see my hand.
- 6.0.14 Ada n wil nii na an onu.
CONJ CL T see my-hand
I see my hand.

- 6.0.15 Ada hla n lu ts'aky i luhk.
 CONJ T CL extinguish case fire
 I just now put the fire out.
- 6.0.16 Da n wil nii guu'piltga as os.
 CONJ CL T see two dogs
 And then I saw two dogs.

In sentences with *mX*, however, the agent co-indexed pronominal is the enclitic associated with the verb:

- 6.0.17 Nah dzuhb u ni waabu.
 T build 1st,sing my house
 I built my house.
- 6.0.18 Nah hla ba'al du lo'ap.
 T T feel 1st, sing rock
 I just felt the rock.
- 6.0.19 Nah luu niidz u hoan.
 T glare-at 1st, sing fish
 I glared at the fish.
- 6.0.20 Nah luu niidzi t i hoan.
 T glare-at 3rd case fish
 He glared at the fish.
- 6.0.21 Hla dim lu ts'aky du luhk.
 T T extinguish 1st, sing fire
 I'm just about to put the fire out.
- 6.0.22 Nah lu ts'aky du luhk.
 T extinguish 1st, sing fire
 I already put the fire out.
- 6.0.23 'Waa yim dūūhik.
 find 1st,plu basket
 We found the basket.

- 6.0.24 'Waa yu derhk.
find 1st,sing basket
I found the basket.
- 6.0.25 Si ts'ik ts'aX u k'uhba 'yu'uxwt.
make AGR nose 1st,sing little men
I'm scolding the boys.
- 6.0.26 Si .ts'aX u hlgu 'yaxwt.
make nose 1st,sing little man
I'm scolding the boy.
- 6.0.27 At aitga t i hlgu 'yu'uxwt.
AGR name 3rd case little men
They're naming the boys.
- 6.0.28 Aitga t i hlgu 'yaxwt.
name 3rd case little man
They're naming the boy.

6.1 The verbal enclitic as a minor agreement system. I characterize the enclitic paradigm that affiliates with the verb and thus inflects it as a 'minor agreement system.' It is a minor system for two reasons: 1) it is optional, and 2) it does not consistently agree in monotransitives with either canonically theta-marked argument. In simple intransitives it consistently co-indexes the proto-patient argument. Likewise in simple monotransitives with two pronominal clitics it consistently co-indexes the proto-patient argument. It might be said to be a basic verb-subject agreement system in this ergative language. But in simple monotransitives with only one pronominal clitic and with marked pre-verbal (*mX*) material this verbal enclitic co-indexes the proto-agent argument (cf. Chart 5 on following page).

7. The pronominal clitic affiliating with X. A pronominal clitic paradigm (cf. Chart 6 on the following page) inflects the pre-verbal (*X*) material. The inflection of *X* constitutes a

second minor agreement system. The data illustrations for this paradigm are to be found in sentences 6.0.4 thru 6.0.17. I characterize this inflection of X as a minor agreement system for two reasons: a) it is optional, and b) the controllee (X) is not a typical or common cross-linguistic morphosyntactic co-occurrence controllee. X is a complex entity, consisting of conjunctions, complementizers (not illustrated in this paper), negative markers (not illustrated in this paper), interrogative markers (not illustrated in this paper), and tense-aspect-mood markers that are not auxiliary verbs (INFL), but rather 'proper' lexical items, i.e., they have consistent phonetic content and are not the creations of inflectional phenomena.

sentence type	controller
intransitive argument	proto-patient
monotransitive with two pronominal clitics	proto-patient argument
monotransitive with one pronominal clitic and <i>uX</i>	none: the verbal enclitic is always absent
monotransitive with one pronominal clitic and <i>mX</i>	proto-agent argument

Chart 5. Verbal enclitic agreement controllers.

	singular	plural
speaker	n, na	...
addressee
other	t	...

Chart 6. Pronominal clitics inflecting X.

8. The inflection meta-system. All three of these agreement systems, the inflection of the verb root to show the number of the patient argument and the two minor agreement systems, can be characterized as one syntactic system in which three principles operate without exception. The principles are these: a) move alpha, understood to include head incorporation, b) leftward movement, c) radically local movement. At this point I assume a fairly abstract d-structure, even abandoning the overt s-structure word order. I further assume that the arguments are clitic phrases, i.e., that they are headed by clitics and that these clitic heads have as complements co-referential NPs. In d-structure the clitics have no phonological shape but are person/number feature bundles. Cf. Figure 1.

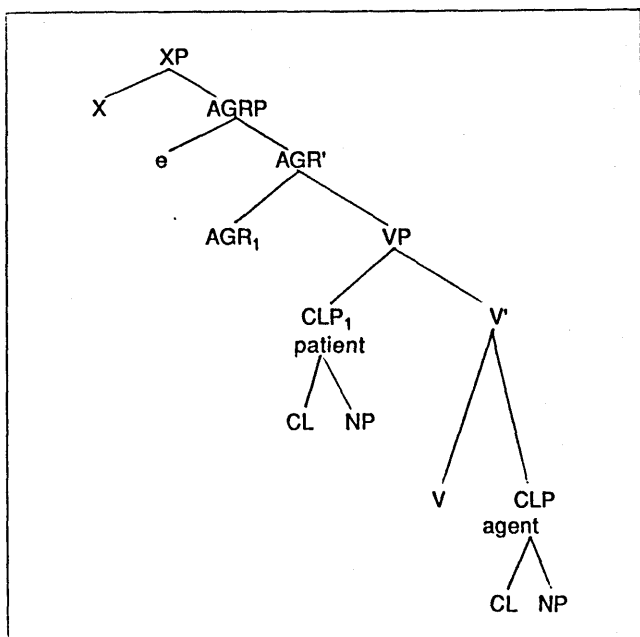

Figure1. Proposed d-structure for SgūūXs monotransitives.

8.1 The inflection maneuver. Elements subject to move-alpha are i) NP, ii) CL, and iii) V. Landing sites for NP are i) empty CLP positions and ii) the specifier to AGR position. Landing sites for CL and V are i) V, ii) AGR, and iii) X. The inflection maneuver is this: starting at the right of d-structure move the first (right-most) element subject to move-alpha into the first (rightmost) available landing site. If no landing site is available, the element does not move. This maneuver is a cyclic one, reading from right to left for all elements subject to move-alpha. The usual constraints on move-alpha, as interpreted by Baker 1988, apply. This one cyclic maneuver will correctly relate all s-structures to a single d-structure (cf. Figures 2, 3, and 4).

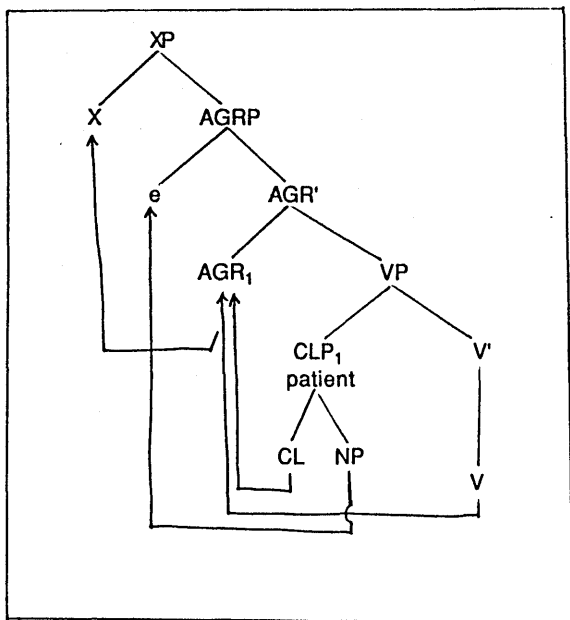

Figure 2. Intransitive with patient argument.

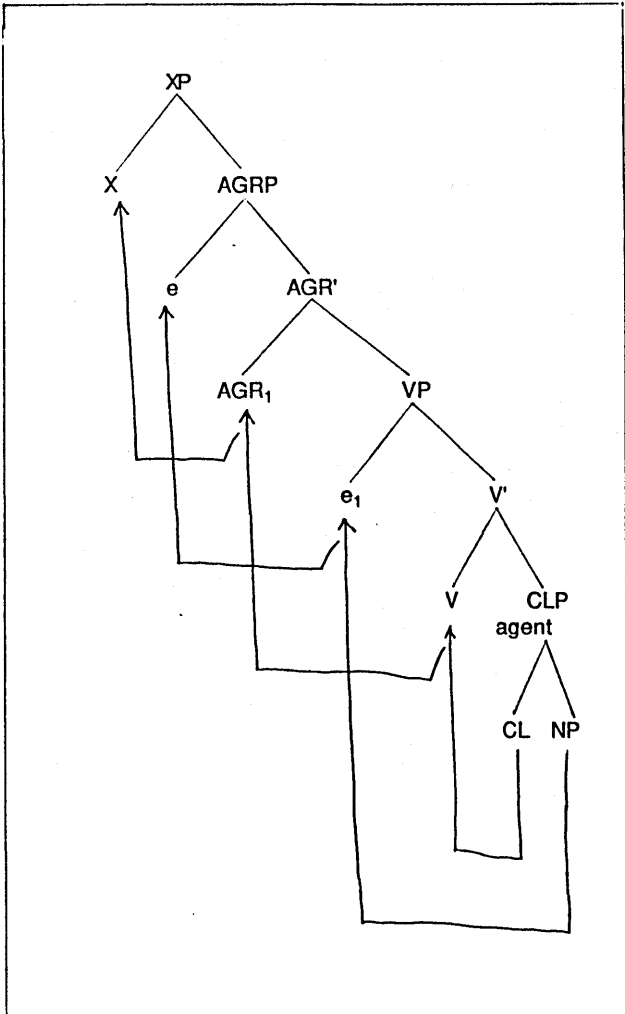

Figure 3. Intransitive with agent argument.

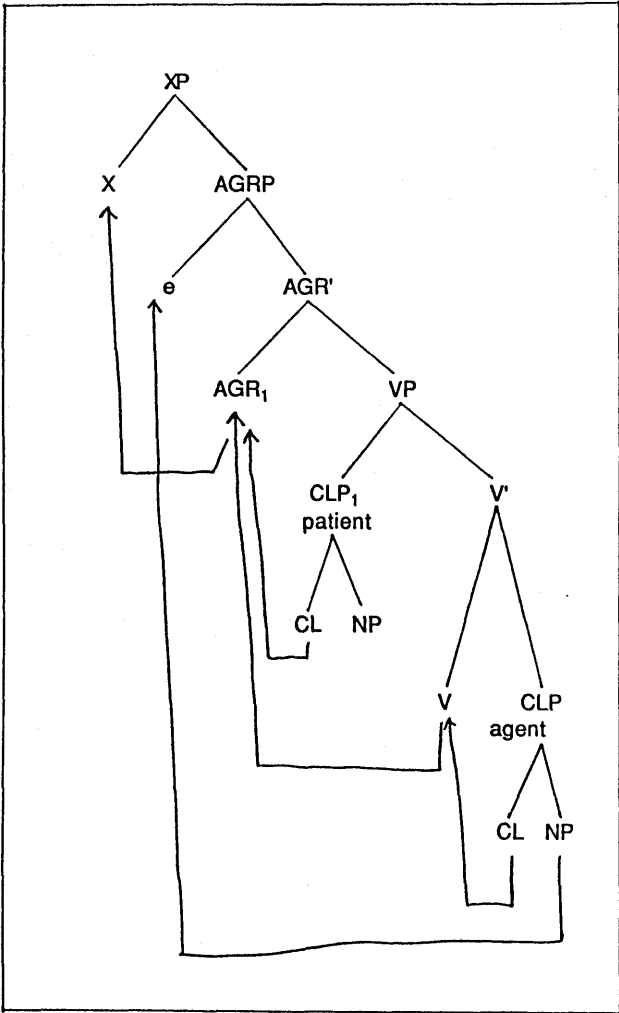

Figure 4. Mono-transitive.

REFERENCES

Baker, Mark C. 1988. Incorporation: a theory of grammatical function changing. Chicago: University of Chicago Press.

Dowty, David. 1987. Thematic proto-roles, subject selection, and lexical semantic defaults. LSA meetings colloquium paper, San Francisco.

Dunn, John A. 1979. A reference grammar for the Coast Tsimshian language. Ottawa: Service canadien d'Ethnologie, dossier 55.

La Pointe, Steven. 1988. Toward a unified theory of agreement. in Barlow and Ferguson (eds). Agreement in natural language. Stanford University: Center for the Study of Language and Information. pp 67-88.

Stemberger, Joseph and Brian MacWhinney. 1988. Are inflected forms stored in the lexicon? in Hammond and Noonan (eds) Theoretical morphology. San Diego: Academic Press. pp 108-118.