

## Search for $CP$ Violation in $B^\pm \rightarrow J/\psi K^\pm$ and $B^\pm \rightarrow \psi(2S)K^\pm$ Decays

G. Bonvicini,<sup>1</sup> D. Cinabro,<sup>1</sup> S. McGee,<sup>1</sup> L. P. Perera,<sup>1</sup> G. J. Zhou,<sup>1</sup> E. Lipeles,<sup>2</sup> S. Pappas,<sup>2</sup> M. Schmidtler,<sup>2</sup> A. Shapiro,<sup>2</sup> W. M. Sun,<sup>2</sup> A. J. Weinstein,<sup>2</sup> F. Würthwein,<sup>2,\*</sup> D. E. Jaffe,<sup>3</sup> G. Masek,<sup>3</sup> H. P. Paar,<sup>3</sup> E. M. Potter,<sup>3</sup> S. Prell,<sup>3</sup> V. Sharma,<sup>3</sup> D. M. Asner,<sup>4</sup> A. Eppich,<sup>4</sup> T. S. Hill,<sup>4</sup> R. J. Morrison,<sup>4</sup> H. N. Nelson,<sup>4</sup> R. A. Briere,<sup>5</sup> B. H. Behrens,<sup>6</sup> W. T. Ford,<sup>6</sup> A. Gritsan,<sup>6</sup> J. Roy,<sup>6</sup> J. G. Smith,<sup>6</sup> J. P. Alexander,<sup>7</sup> R. Baker,<sup>7</sup> C. Bebek,<sup>7</sup> B. E. Berger,<sup>7</sup> K. Berkelman,<sup>7</sup> F. Blanc,<sup>7</sup> V. Boisvert,<sup>7</sup> D. G. Cassel,<sup>7</sup> M. Dickson,<sup>7</sup> P. S. Drell,<sup>7</sup> K. M. Ecklund,<sup>7</sup> R. Ehrlich,<sup>7</sup> A. D. Foland,<sup>7</sup> P. Gaidarev,<sup>7</sup> L. Gibbons,<sup>7</sup> B. Gittelman,<sup>7</sup> S. W. Gray,<sup>7</sup> D. L. Hartill,<sup>7</sup> B. K. Heltsley,<sup>7</sup> P. I. Hopman,<sup>7</sup> C. D. Jones,<sup>7</sup> D. L. Kreinick,<sup>7</sup> M. Lohner,<sup>7</sup> A. Magerkurth,<sup>7</sup> T. O. Meyer,<sup>7</sup> N. B. Mistry,<sup>7</sup> E. Nordberg,<sup>7</sup> J. R. Patterson,<sup>7</sup> D. Peterson,<sup>7</sup> D. Riley,<sup>7</sup> J. G. Thayer,<sup>7</sup> P. G. Thies,<sup>7</sup> B. Valant-Spaight,<sup>7</sup> A. Warburton,<sup>7</sup> P. Avery,<sup>8</sup> C. Prescott,<sup>8</sup> A. I. Rubiera,<sup>8</sup> J. Yelton,<sup>8</sup> J. Zheng,<sup>8</sup> G. Brandenburg,<sup>9</sup> A. Ershov,<sup>9</sup> Y. S. Gao,<sup>9</sup> D. Y.-J. Kim,<sup>9</sup> R. Wilson,<sup>9</sup> T. E. Browder,<sup>10</sup> Y. Li,<sup>10</sup> J. L. Rodriguez,<sup>10</sup> H. Yamamoto,<sup>10</sup> T. Bergfeld,<sup>11</sup> B. I. Eisenstein,<sup>11</sup> J. Ernst,<sup>11</sup> G. E. Gladding,<sup>11</sup> G. D. Gollin,<sup>11</sup> R. M. Hans,<sup>11</sup> E. Johnson,<sup>11</sup> I. Karliner,<sup>11</sup> M. A. Marsh,<sup>11</sup> M. Palmer,<sup>11</sup> C. Plager,<sup>11</sup> C. Sedlack,<sup>11</sup> M. Selen,<sup>11</sup> J. J. Thaler,<sup>11</sup> J. Williams,<sup>11</sup> K. W. Edwards,<sup>12</sup> R. Janicek,<sup>13</sup> P. M. Patel,<sup>13</sup> A. J. Sadoff,<sup>14</sup> R. Ammar,<sup>15</sup> A. Bean,<sup>15</sup> D. Besson,<sup>15</sup> R. Davis,<sup>15</sup> N. Kwak,<sup>15</sup> X. Zhao,<sup>15</sup> S. Anderson,<sup>16</sup> V. V. Frolov,<sup>16</sup> Y. Kubota,<sup>16</sup> S. J. Lee,<sup>16</sup> R. Mahapatra,<sup>16</sup> J. J. O'Neill,<sup>16</sup> R. Poling,<sup>16</sup> T. Riehle,<sup>16</sup> A. Smith,<sup>16</sup> J. Urheim,<sup>16</sup> S. Ahmed,<sup>17</sup> M. S. Alam,<sup>17</sup> S. B. Athar,<sup>17</sup> L. Jian,<sup>17</sup> L. Ling,<sup>17</sup> A. H. Mahmood,<sup>17,†</sup> M. Saleem,<sup>17</sup> S. Timm,<sup>17</sup> F. Wappler,<sup>17</sup> A. Anastassov,<sup>18</sup> J. E. Duboscq,<sup>18</sup> K. K. Gan,<sup>18</sup> C. Gwon,<sup>18</sup> T. Hart,<sup>18</sup> K. Honscheid,<sup>18</sup> D. Hufnagel,<sup>18</sup> H. Kagan,<sup>18</sup> R. Kass,<sup>18</sup> T. K. Pedlar,<sup>18</sup> H. Schwarthoff,<sup>18</sup> J. B. Thayer,<sup>18</sup> E. von Toerne,<sup>18</sup> M. M. Zoeller,<sup>18</sup> S. J. Richichi,<sup>19</sup> H. Severini,<sup>19</sup> P. Skubic,<sup>19</sup> A. Undrus,<sup>19</sup> S. Chen,<sup>20</sup> J. Fast,<sup>20</sup> J. W. Hinson,<sup>20</sup> J. Lee,<sup>20</sup> N. Menon,<sup>20</sup> D. H. Miller,<sup>20</sup> E. I. Shibata,<sup>20</sup> I. P. J. Shipsey,<sup>20</sup> V. Pavlunin,<sup>20</sup> D. Cronin-Hennessy,<sup>21</sup> Y. Kwon,<sup>21,‡</sup> A. L. Lyon,<sup>21</sup> E. H. Thorndike,<sup>21</sup> C. P. Jessop,<sup>22</sup> H. Marsiske,<sup>22</sup> M. L. Perl,<sup>22</sup> V. Savinov,<sup>22</sup> D. Ugolini,<sup>22</sup> X. Zhou,<sup>22</sup> T. E. Coan,<sup>23</sup> V. Fadeyev,<sup>23</sup> Y. Maravin,<sup>23</sup> I. Narsky,<sup>23</sup> R. Stroynowski,<sup>23</sup> J. Ye,<sup>23</sup> T. Wlodek,<sup>23</sup> M. Artuso,<sup>24</sup> R. Ayad,<sup>24</sup> C. Boulahouache,<sup>24</sup> K. Bukin,<sup>24</sup> E. Dambasuren,<sup>24</sup> S. Karamov,<sup>24</sup> G. Majumder,<sup>24</sup> G. C. Moneti,<sup>24</sup> R. Mountain,<sup>24</sup> S. Schuh,<sup>24</sup> T. Skwarnicki,<sup>24</sup> S. Stone,<sup>24</sup> G. Viehhauser,<sup>24</sup> J. C. Wang,<sup>24</sup> A. Wolf,<sup>24</sup> J. Wu,<sup>24</sup> S. Kopp,<sup>25</sup> S. E. Csorna,<sup>26</sup> I. Danko,<sup>26</sup> K. W. McLean,<sup>26</sup> Sz. Márka,<sup>26</sup> Z. Xu,<sup>26</sup> R. Godang,<sup>27</sup> K. Kinoshita,<sup>27,§</sup> I. C. Lai,<sup>27</sup> and S. Schrenk<sup>27</sup>

(CLEO Collaboration)

<sup>1</sup>Wayne State University, Detroit, Michigan 48202

<sup>2</sup>California Institute of Technology, Pasadena, California 91125

<sup>3</sup>University of California, San Diego, La Jolla, California 92093

<sup>4</sup>University of California, Santa Barbara, California 93106

<sup>5</sup>Carnegie Mellon University, Pittsburgh, Pennsylvania 15213

<sup>6</sup>University of Colorado, Boulder, Colorado 80309-0390

<sup>7</sup>Cornell University, Ithaca, New York 14853

<sup>8</sup>University of Florida, Gainesville, Florida 32611

<sup>9</sup>Harvard University, Cambridge, Massachusetts 02138

<sup>10</sup>University of Hawaii at Manoa, Honolulu, Hawaii 96822

<sup>11</sup>University of Illinois, Urbana-Champaign, Illinois 61801

<sup>12</sup>Carleton University, Ottawa, Ontario, Canada K1S 5B6 and the Institute of Particle Physics, Canada

<sup>13</sup>McGill University, Montréal, Québec, Canada H3A 2T8 and the Institute of Particle Physics, Canada

<sup>14</sup>Ithaca College, Ithaca, New York 14850

<sup>15</sup>University of Kansas, Lawrence, Kansas 66045

<sup>16</sup>University of Minnesota, Minneapolis, Minnesota 55455

<sup>17</sup>State University of New York at Albany, Albany, New York 12222

<sup>18</sup>The Ohio State University, Columbus, Ohio 43210

<sup>19</sup>University of Oklahoma, Norman, Oklahoma 73019

<sup>20</sup>Purdue University, West Lafayette, Indiana 47907

<sup>21</sup>University of Rochester, Rochester, New York 14627

<sup>22</sup>Stanford Linear Accelerator Center, Stanford University, Stanford, California 94309

<sup>23</sup>Southern Methodist University, Dallas, Texas 75275

<sup>24</sup>Syracuse University, Syracuse, New York 13244

<sup>25</sup>University of Texas, Austin, Texas 78712

<sup>26</sup>Vanderbilt University, Nashville, Tennessee 37235

<sup>27</sup>Virginia Polytechnic Institute and State University, Blacksburg, Virginia 24061

(Received 2 March 2000)

We present a search for direct  $CP$  violation in  $B^\pm \rightarrow J/\psi K^\pm$  and  $B^\pm \rightarrow \psi(2S)K^\pm$  decays. In a sample of  $9.7 \times 10^6 B\bar{B}$  meson pairs collected with the CLEO detector, we have fully reconstructed 534  $B^\pm \rightarrow J/\psi K^\pm$  and 120  $B^\pm \rightarrow \psi(2S)K^\pm$  decays with very low background. We have measured the  $CP$ -violating charge asymmetry to be  $[+1.8 \pm 4.3(\text{stat}) \pm 0.4(\text{syst})]\%$  for  $B^\pm \rightarrow J/\psi K^\pm$  and  $[+2.0 \pm 9.1(\text{stat}) \pm 1.0(\text{syst})]\%$  for  $B^\pm \rightarrow \psi(2S)K^\pm$ .

PACS numbers: 11.30.Er, 13.25.Hw

$CP$  violation arises naturally in the standard model with three quark generations [1]; however, it still remains one of the least experimentally constrained sectors of the standard model. Decays of  $B$  mesons promise to be a fertile ground for  $CP$ -violation studies. Direct  $CP$  violation, also called  $CP$  violation in decay, occurs when the amplitude for a decay and its  $CP$ -conjugate process have different magnitudes. Direct  $CP$  violation can be observed in both charged and neutral  $B$  meson decays. At least two interfering amplitudes with different  $CP$ -odd (weak) and  $CP$ -even (strong or electromagnetic) phases are the necessary ingredients for direct  $CP$  violation. For the decays governed by the  $b \rightarrow c\bar{c}s$  quark transition, such as  $B^\pm \rightarrow J/\psi K^\pm$  and  $B^0(\bar{B}^0) \rightarrow J/\psi K_S^0$ , there are interfering standard model tree and penguin amplitudes (Fig. 1). These amplitudes could have a significant relative strong phase. The relative weak phase, however, is expected to be very small [2]. Therefore, the  $CP$  asymmetry in  $B^\pm \rightarrow J/\psi K^\pm$  decay is firmly predicted in the standard model to be much smaller than the 4% precision of our measurement.

A  $CP$  asymmetry of  $\mathcal{O}(10\%)$  in  $B^\pm \rightarrow J/\psi K^\pm$  decay is possible in a specific two-Higgs doublet model described in Ref. [3]; such a large asymmetry could be measured with our current data. In order to constrain any of the new physics models, however, we need to know the relative strong phases which are difficult to determine.

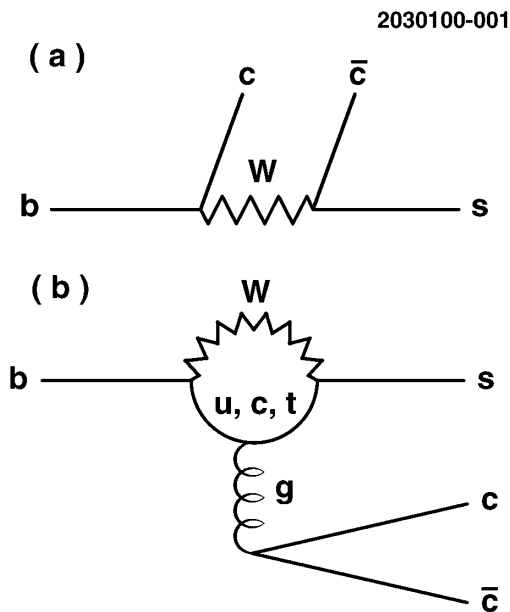

FIG. 1. Tree (a) and penguin (b) diagrams for the  $b \rightarrow c\bar{c}s$  transition.

The measurement of the  $CP$  asymmetry in  $B^0(\bar{B}^0) \rightarrow J/\psi K_S^0$  decay allows an extraction of the relative phase between the  $B^0 - \bar{B}^0$  mixing amplitude and the  $b \rightarrow c\bar{c}s$  decay amplitude [4]. In the standard model this phase is equal to  $\sin 2\beta$ , where  $\beta \equiv \arg(-V_{cd}V_{cb}^*/V_{td}V_{tb}^*)$ . An observation of  $CP$  asymmetry in  $B^\pm \rightarrow J/\psi K^\pm$  decay at a few per cent or larger level will be a clear evidence for sources of  $CP$  violation beyond the standard model. Such an observation will also mean that a measurement of the  $CP$  asymmetry in  $B^0(\bar{B}^0) \rightarrow J/\psi K_S^0$  decay no longer determines  $\sin 2\beta$ .

If some mechanism causes direct  $CP$  violation to occur in  $B^\pm \rightarrow J/\psi K^\pm$  decays, then the same mechanism could generate a  $CP$  asymmetry in  $B^\pm \rightarrow \psi(2S)K^\pm$  mode. Final state strong interactions, however, could be quite different for  $J/\psi K$  and  $\psi(2S)K$  states; thus, we measured  $CP$ -violating charge asymmetries separately for  $B^\pm \rightarrow J/\psi K^\pm$  and  $B^\pm \rightarrow \psi(2S)K^\pm$  decay modes.

The data used for our measurement were collected at the Cornell Electron Storage Ring (CESR) with two configurations of the CLEO detector called CLEO II [5] and CLEO II.V [6]. The components of the CLEO detector most relevant to this analysis are the charged particle tracking system, the CsI electromagnetic calorimeter, and the muon chambers. In CLEO II the momenta of charged particles are measured in a tracking system consisting of a 6-layer straw tube chamber, a 10-layer precision drift chamber, and a 51-layer main drift chamber, all operating inside a 1.5 T solenoidal magnet. The main drift chamber also provides a measurement of the specific ionization,  $dE/dx$ , used for particle identification. For CLEO II.V, the straw tube chamber was replaced with a 3-layer silicon vertex detector, and the gas in the main drift chamber was changed from an argon-ethane to a helium-propane mixture. The muon chambers consist of proportional counters placed at increasing depth in a steel absorber.

For this measurement we used  $9.2 \text{ fb}^{-1}$  of  $e^+e^-$  data taken at the  $Y(4S)$  resonance and  $4.6 \text{ fb}^{-1}$  taken 60 MeV below the  $Y(4S)$  resonance. In  $Y(4S)$  decays  $B^+$  mesons are born only in pairs with  $B^-$  mesons, therefore  $B^+$  and  $B^-$  mesons are produced in equal numbers. Two thirds of the data used were collected with the CLEO II.V detector. The simulated event samples used in this analysis were generated with a GEANT-based [7] simulation of the CLEO detector response and were processed in a similar manner as the data.

We reconstructed  $\psi^{(l)} \rightarrow e^+e^-$  and  $\psi^{(l)} \rightarrow \mu^+\mu^-$  decays, where  $\psi^{(l)}$  stands for either  $J/\psi$  or  $\psi(2S)$ . We also reconstructed  $\psi(2S)$  in the  $\psi(2S) \rightarrow J/\psi \pi^+ \pi^-$  channel.

Electron candidates were identified based on the ratio of the track momentum to the associated shower energy in the CsI calorimeter and on the specific ionization in the drift chamber. We recovered some of the bremsstrahlung photons by selecting the photon shower with the smallest opening angle with respect to the direction of the  $e^\pm$  track evaluated at the interaction point, and then required this opening angle to be smaller than  $5^\circ$ . We therefore refer to the  $e^+(\gamma)e^-(\gamma)$  invariant mass when we describe the  $\psi^{(\prime)} \rightarrow e^+e^-$  reconstruction.

For the  $\psi^{(\prime)} \rightarrow \mu^+\mu^-$  reconstruction, one of the muon candidates was required to penetrate the steel absorber to a depth greater than three nuclear interaction lengths. We relaxed the absorber penetration requirement for the second muon candidate if it was not expected to reach a muon chamber either because its energy was too low or because it did not point to a region of the detector covered by the muon chambers. For these muon candidates we required the ionization signature in the CsI calorimeter to be consistent with that of a muon.

We extensively used normalized variables, taking advantage of well-understood track and photon-shower four-momentum covariance matrices to calculate the expected resolution for each combination. The use of normalized variables allows uniform candidate selection criteria to be applied to the data collected with the CLEO II and CLEO II.V detector configurations. The  $\psi^{(\prime)}$  candidates were selected using the normalized invariant mass. For example, the normalized  $\mu^+\mu^-$  invariant mass is defined as  $[M(\mu^+\mu^-) - M_{\psi^{(\prime)}}]/\sigma(M)$ , where  $M_{\psi^{(\prime)}}$  is the world average value of the  $J/\psi$  or  $\psi(2S)$  mass [8] and  $\sigma(M)$  is the calculated mass resolution for that particular  $\mu^+\mu^-$  combination. The average  $\ell^+\ell^-$  invariant mass resolution is approximately  $12 \text{ MeV}/c^2$ . We required the normalized  $\mu^+\mu^-$  mass to be from  $-4$  to  $3$  for  $J/\psi \rightarrow \mu^+\mu^-$  can-

didates and from  $-3$  to  $3$  for  $\psi(2S) \rightarrow \mu^+\mu^-$  candidates. We required the normalized  $e^+(\gamma)e^-(\gamma)$  mass to be from  $-10$  to  $3$  for  $J/\psi \rightarrow e^+e^-$  candidates and from  $-3$  to  $3$  for  $\psi(2S) \rightarrow e^+e^-$  candidates. For each  $\psi^{(\prime)} \rightarrow \ell^+\ell^-$  candidate, we performed a fit constraining its mass to the world average value. We selected the  $\psi(2S) \rightarrow J/\psi\pi^+\pi^-$  candidates by requiring the absolute value of the normalized  $J/\psi\pi^+\pi^-$  mass to be less than  $3$  and by requiring the  $\pi^+\pi^-$  invariant mass to be greater than  $400 \text{ MeV}/c^2$ . The average  $J/\psi\pi^+\pi^-$  mass resolution is approximately  $3 \text{ MeV}/c^2$ . For each  $\psi(2S) \rightarrow J/\psi\pi^+\pi^-$  candidate, we performed a fit constraining its mass to the world average value. Well-measured tracks consistent with originating at the  $e^+e^-$  interaction point were selected as the  $K^\pm$  candidates. In order to avoid any additional charge-correlated systematic bias in the  $K^\pm$  selection, we did not impose any particle identification requirements on the  $K^\pm$  candidates.

The  $B^\pm \rightarrow J/\psi K^\pm$  and  $B^\pm \rightarrow \psi(2S)K^\pm$  candidates were selected by means of two observables. The first observable is the difference between the energy of the  $B^\pm$  candidate and the beam energy,  $\Delta E \equiv E(B^\pm) - E_{\text{beam}}$ . The average resolution in  $\Delta E$  is  $10 \text{ MeV}$  ( $8 \text{ MeV}$ ) for the  $B^\pm \rightarrow J/\psi K^\pm$  [ $B^\pm \rightarrow \psi(2S)K^\pm$ ] candidates. We used the normalized  $\Delta E$  observable for candidate selection and required  $|\Delta E|/\sigma(\Delta E) < 3$ . The second observable is the beam-constrained  $B$  mass,  $M(B) \equiv \sqrt{E_{\text{beam}}^2 - p^2(B)}$ , where  $p(B)$  is the magnitude of the  $B$  candidate momentum. The resolution in  $M(B)$  for the  $B^\pm \rightarrow \psi^{(\prime)}K^\pm$  candidates is  $2.7 \text{ MeV}/c^2$  and is dominated by the beam energy spread. The  $M(B)$  distributions for the  $B^\pm \rightarrow J/\psi K^\pm$  and  $B^\pm \rightarrow \psi(2S)K^\pm$  candidates passing the  $|\Delta E|/\sigma(\Delta E) < 3$  requirement are shown in Fig. 2. We used the normalized  $M(B)$  observable for candidate selection and required  $|M(B) - M_B|/\sigma(M) < 3$ .

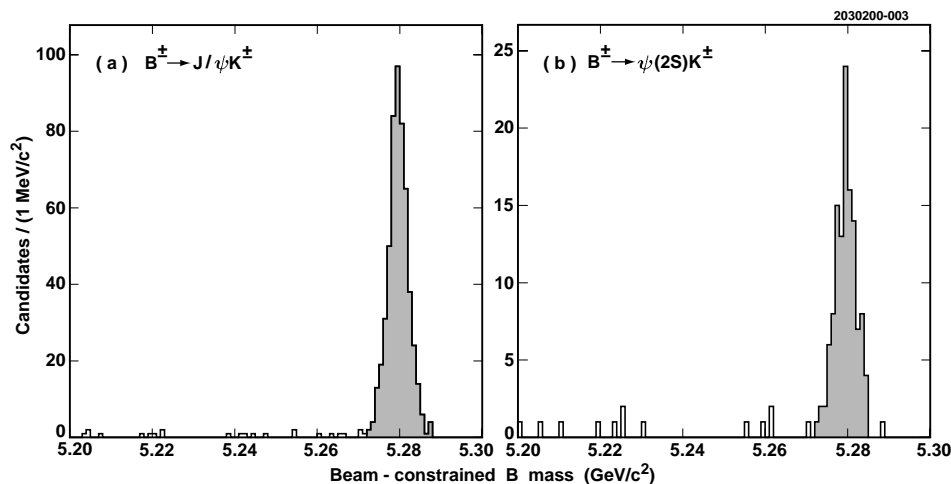

FIG. 2. Beam-constrained  $B$  mass distribution for (a)  $B^\pm \rightarrow J/\psi K^\pm$  and (b)  $B^\pm \rightarrow \psi(2S)K^\pm$  candidates passing the  $|\Delta E|/\sigma(\Delta E) < 3$  requirement. The shaded parts of the histograms represent the 534  $B^\pm \rightarrow J/\psi K^\pm$  and 120  $B^\pm \rightarrow \psi(2S)K^\pm$  candidates that pass the  $|M(B) - M_B|/\sigma(M) < 3$  requirement.

The  $CP$ -violating charge asymmetry in  $B^\pm \rightarrow J/\psi K^\pm$  decays is defined as a branching fraction asymmetry

$$\mathcal{A}_{CP} \equiv \frac{\mathcal{B}(B^- \rightarrow J/\psi K^-) - \mathcal{B}(B^+ \rightarrow J/\psi K^+)}{\mathcal{B}(B^- \rightarrow J/\psi K^-) + \mathcal{B}(B^+ \rightarrow J/\psi K^+)}.$$

In this definition we adopted the sign convention from Ref. [9]. The same definition is used for the  $B^\pm \rightarrow \psi(2S)K^\pm$  mode.

Table I lists signal yields together with observed charge asymmetries. The possible sources of systematic uncertainty and bias in the  $\mathcal{A}_{CP}$  measurement are described below.

*Background.*—From fits to the beam-constrained mass distributions (Fig. 2), we estimated the combinatorial background to be  $3.5_{-1.7}^{+2.8}$  ( $1.7_{-1.0}^{+2.0}$ ) for  $B^\pm \rightarrow J/\psi K^\pm$  [ $B^\pm \rightarrow \psi(2S)K^\pm$ ] mode. The background from  $B^\pm \rightarrow \psi^{(l)}\pi^\pm$  decays has to be added because  $B^\pm \rightarrow \psi^{(l)}\pi^\pm$  candidates contribute to the beam-constrained mass peaks. Using simulated events, we estimated the background from  $B^\pm \rightarrow \psi^{(l)}\pi^\pm$  decays to be  $1.5 \pm 0.5$  events for  $B^\pm \rightarrow J/\psi K^\pm$  and 0.1 event for  $B^\pm \rightarrow \psi(2S)K^\pm$  mode. We assumed the branching ratio of  $\mathcal{B}(B^\pm \rightarrow J/\psi\pi^\pm)/\mathcal{B}(B^\pm \rightarrow J/\psi K^\pm) = (5.1 \pm 1.4)\%$  [8]; the same value was assumed for  $B^\pm \rightarrow \psi(2S)\pi^\pm$  decays. Total background is therefore estimated to be  $5_{-2}^{+3}$  events for  $B^\pm \rightarrow J/\psi K^\pm$  and  $2_{-1}^{+2}$  events for  $B^\pm \rightarrow \psi(2S)K^\pm$  mode. As a check, we used samples of simulated events together with the data collected below the  $B\bar{B}$  production threshold and estimated total background to be  $3.3 \pm 0.8$  events for  $B^\pm \rightarrow J/\psi K^\pm$  and  $3.7 \pm 0.9$  events for  $B^\pm \rightarrow \psi(2S)K^\pm$  mode. We verified that the simulation accurately reproduced the rate and distribution of candidates in the data in the  $\Delta E$  vs  $M(B)$  plane near, but not including, the signal region. Backgrounds are expected to be  $CP$  symmetric. We measured the charge asymmetry for the candidates in the sideband regions of the  $\Delta E$  and  $M(B)$  distributions to be  $(+2.2 \pm 4.1)\%$  for  $B^\pm \rightarrow J/\psi K^\pm$  and  $(-1.2 \pm 6.4)\%$  for  $B^\pm \rightarrow \psi(2S)K^\pm$ . We also verified that our final result does not critically depend on the assumption of zero  $CP$  asymmetry for background events. We assumed that the number of background events entering our sample follows a Poisson distribution with a mean of five events for  $B^\pm \rightarrow J/\psi K^\pm$  and four events for the  $B^\pm \rightarrow \psi(2S)K^\pm$  mode. We also assumed that the  $CP$ -violating charge asymmetry for the background is  $+30\%$ . Using Monte Carlo techniques, we found that background with such properties introduces a  $+0.3\%$  ( $+1.0\%$ ) bias in our  $\mathcal{A}_{CP}$  measurement for the  $B^\pm \rightarrow J/\psi K^\pm$  [ $B^\pm \rightarrow \psi(2S)K^\pm$ ] mode. We assigned a

systematic uncertainty on  $\mathcal{A}_{CP}$  of 0.3% for  $B^\pm \rightarrow J/\psi K^\pm$  and 1.0% for  $B^\pm \rightarrow \psi(2S)K^\pm$ .

*Charge asymmetry for inclusive tracks.*—Collisions of particles with the nuclei in the detector material occasionally result in recoil protons, but almost never in recoil antiprotons. To fake a  $K^+$  candidate, a recoil proton has to have a momentum of at least 1.2 GeV/c and its track should be consistent with originating at the  $e^+e^-$  interaction point. In order to study the effect of possible recoil proton contamination of our  $K^+$  sample, we selected inclusive tracks satisfying the same track quality criteria as for the charged kaon candidates in the  $B^\pm \rightarrow \psi^{(l)}K^\pm$  reconstruction. The kaon momentum in the laboratory frame is between 1.2 and 1.4 GeV/c for the  $B^\pm \rightarrow \psi(2S)K^\pm$  mode and between 1.55 and 1.85 GeV/c for the  $B^\pm \rightarrow J/\psi K^\pm$  mode. We have indeed found more positive than negative tracks in these two momentum ranges. For all tracks with momentum between 1.2 and 1.4 GeV/c, we have observed a charge asymmetry of  $(N^- - N^+)/ (N^- + N^+) = (-0.22 \pm 0.03)\%$ ; the corresponding number for tracks with momentum between 1.55 and 1.85 GeV/c is  $(-0.17 \pm 0.04)\%$ . Besides increasing our confidence that our track reconstruction procedure does not introduce significant charge-correlated bias, this study also confirms that the number of recoil protons entering the pool of  $K^+$  candidates is negligible even before the reconstruction of the full  $B^\pm \rightarrow \psi^{(l)}K^\pm$  decay chain. We did not assign any systematic uncertainty.

*Difference in  $K^+$  vs  $K^-$  detection efficiencies.*—The flavor of the  $B$  meson is tagged by the charged kaon; therefore, we searched for charge-correlated systematic bias associated with the  $K^\pm$  detection and momentum measurement. The cross sections for nuclear interactions are larger for negative than for positive kaons from  $B^\pm \rightarrow \psi^{(l)}K^\pm$  decays. We used two methods to evaluate the difference in  $K^+$  vs  $K^-$  detection efficiencies. In the first method we performed an analytic calculation of the expected asymmetry, combining the data on the nuclear interaction cross sections for the  $K^+$  and  $K^-$  mesons [8] with the known composition of the CLEO detector material. In the second method we used the GEANT-based simulation of the CLEO detector response, processing the simulated events in a similar manner as the data. Both methods are in excellent agreement that the  $K^+$  reconstruction efficiency is approximately 0.6% higher than the  $K^-$  reconstruction efficiency. The corresponding charge-correlated detection efficiency asymmetry is therefore  $-0.3\%$ . We applied a  $+0.3\%$  correction to the measured values of  $\mathcal{A}_{CP}$  both for  $B^\pm \rightarrow J/\psi K^\pm$  and for  $B^\pm \rightarrow \psi(2S)K^\pm$  modes.

TABLE I. Number of selected candidates, the observed charge asymmetry, and the corrected asymmetry.

Mode	$N(B^\pm)$	$N(B^-)$	$N(B^+)$	$\frac{N(B^-) - N(B^+)}{N(B^-) + N(B^+)}$	$\mathcal{A}_{CP}$
$B^\pm \rightarrow J/\psi K^\pm$	534	271	263	$(+1.5 \pm 4.3)\%$	$[+1.8 \pm 4.3(\text{stat}) \pm 0.4(\text{syst})]\%$
$B^\pm \rightarrow \psi(2S)K^\pm$	120	61	59	$(+1.7 \pm 9.1)\%$	$[+2.0 \pm 9.1(\text{stat}) \pm 1.0(\text{syst})]\%$

We assigned 100% of the correction as a systematic uncertainty.

*Bias in  $K^+$  vs  $K^-$  momentum measurement.*—This bias will separate the  $\Delta E \equiv E(B^\pm) - E_{\text{beam}}$  peaks for  $B^+$  and  $B^-$  candidates so that the requirement on  $\Delta E$  can manifest a preference for the  $B$  candidates of a certain sign. We measured the difference in mean  $\Delta E$  for the  $B^+$  and  $B^-$  candidates to be  $0.6 \pm 0.8$  MeV. This result is consistent with zero and very small compared to the approximately  $\pm 30$  MeV window used in the  $\Delta E$  requirement. We also used high-momentum muon tracks from  $e^+e^- \rightarrow \mu^+\mu^-$  events as well as samples of  $D^0$  and  $D_{(s)}^\pm$  meson decays [9] to put stringent limits on possible charge-correlated bias in the momentum measurement. We conclude that the bias in  $K^+$  vs  $K^-$  momentum reconstruction is negligible for our  $CP$ -violation measurement.

In conclusion, we have measured the  $CP$ -violating charge asymmetry to be  $[+1.8 \pm 4.3(\text{stat}) \pm 0.4(\text{syst})]\%$  for  $B^\pm \rightarrow J/\psi K^\pm$  and  $[+2.0 \pm 9.1(\text{stat}) \pm 1.0(\text{syst})]\%$  for  $B^\pm \rightarrow \psi(2S)K^\pm$ . These values of  $\mathcal{A}_{CP}$  include a  $+0.3\%$  correction due to a slightly higher reconstruction efficiency for the positive kaons. Our results are consistent with the standard model expectations and provide the first experimental test of the assumption that direct  $CP$  violation is negligible in  $B \rightarrow \psi^{(\prime)}K$  decays.

We gratefully acknowledge the effort of the CESR staff in providing us with excellent luminosity and running conditions. We thank A. Soni and M. Neubert for useful discussions. This work was supported by the National Science Foundation, the U.S. Department of Energy, the Research Corporation, the Natural Sciences and Engineering Research Council of Canada, the A. P. Sloan Foundation,

the Swiss National Science Foundation, and the Alexander von Humboldt Stiftung.

---

\*Permanent address: Massachusetts Institute of Technology, Cambridge, MA 02139.

†Permanent address: University of Texas–Pan American, Edinburg, TX 78539.

‡Permanent address: Yonsei University, Seoul 120-749, Korea.

§Permanent address: University of Cincinnati, Cincinnati, OH 45221.

- [1] M. Kobayashi and T. Maskawa, *Prog. Theor. Phys.* **49**, 652 (1973).
- [2] For a recent review, see Y. Nir, Report No. IASSNS-HEP-99-96, hep-ph/9911321.
- [3] G. Wu and A. Soni, Report No. BNL-HET-99/40, hep-ph/9911419; K. Kiers, A. Soni, and G. Wu, *Phys. Rev. D* **59**, 096001 (1999).
- [4] OPAL Collaboration, K. Ackerstaff *et al.*, *Eur. Phys. J. C* **5**, 379 (1998); CDF Collaboration, T. Affolder *et al.*, *Phys. Rev. D* **61**, 072005 (2000); ALEPH Collaboration, R. Barate *et al.*, Report No. ALEPH 99-099, CONF-99-054, 1999.
- [5] CLEO Collaboration, Y. Kubota *et al.*, *Nucl. Instrum. Methods Phys. Res., Sect. A* **320**, 66 (1992).
- [6] T. S. Hill, *Nucl. Instrum. Methods Phys. Res., Sect. A* **418**, 32 (1998).
- [7] CERN Program Library Long Writeup W5013, 1993.
- [8] Particle Data Group, C. Caso *et al.*, *Eur. Phys. J. C* **3**, 1 (1998).
- [9] CLEO Collaboration, S. Chen *et al.*, Report No. CLNS 99/1651, CLEO 99-17, hep-ex/0001009, *Phys. Rev. Lett.* (to be published).